

# BELNIMHSC3000

## 1.2V 3000 mAh

(Type): **LP43SC3000P**

Specifications of single cell

Nominal voltage		1.2V	
Capacity		0.2C Discharge	
	Minimum	300min	
	Typical	315min	
Dimensions		mm	
	Diameter	22.5 <sup>-0.7</sup>	
	Height	43.0 <sup>-1.0</sup>	
Weight(Approximately)		gram 53	
Internal Impedance At 1000 Hz		10mΩ(Max) After Charge )	
Charge	Standard	300mA(0.1C)x16hrs	
	Rapid	600mA(0.2C)x6.0hrs	
Ambient temperature	Charge	°C	
		standard	0°C to 40°C
		Rapid	0°C to 40°C
	Discharge		-20°C to 50°C
	Storage		-20°C to 50°C

PVC (Dimensions with tube)

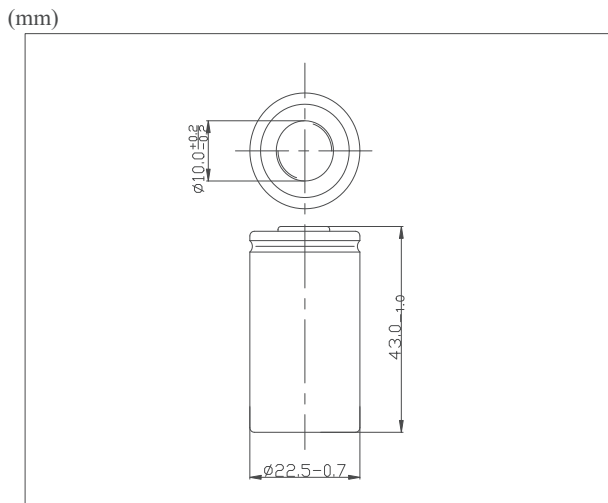

Note:

- Nominal capacity, rated at 0.2C 20°C.
- Average capacity, for reference only.
- Weight and internal impedance are For reference.
- 

### Typical characteristics

Standard charge

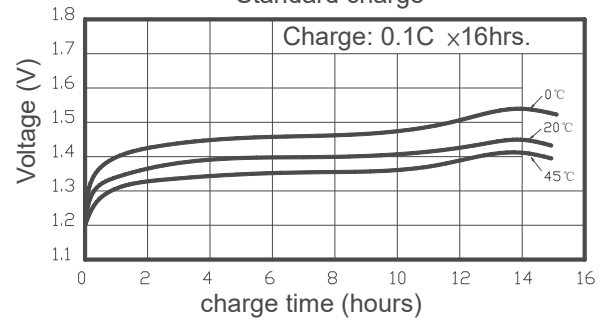

Rapid charge

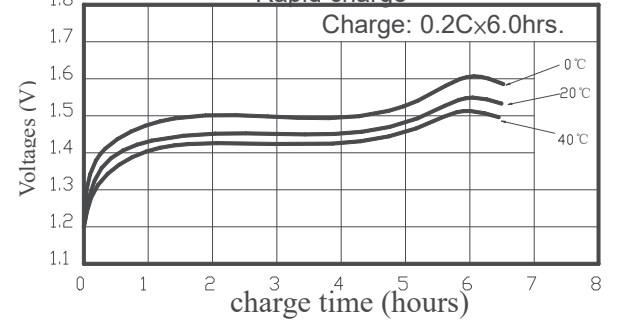

Discharge characteristics

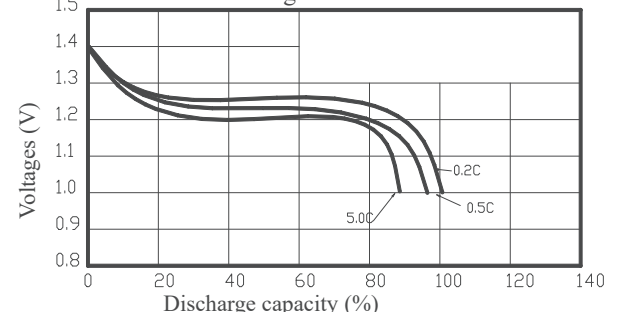

Cycle life characteristics

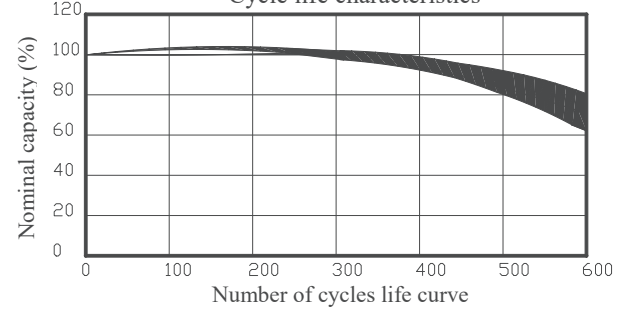

Charge retention curves of Ni-MH cylindrical cell At various storage temperature

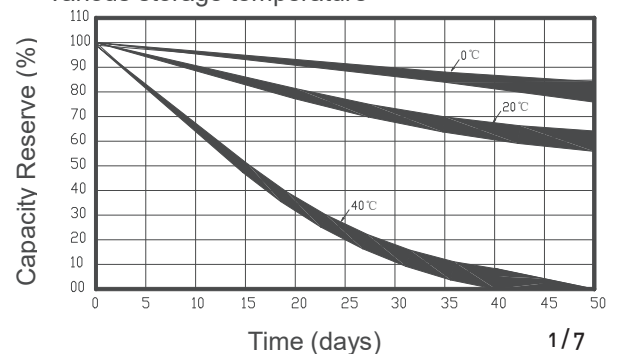

# BELNIMHSC3000

## 1.2V 3000 mAh



Standard according as IEC of test cycle life.

### 1. PREFACE

The specification is suitable for the performance of NI-MH rechargeable battery produced by the SHENZHEN FBTECH CO., LTD.

### 2. MODEL

SC3000mAh 1.2V

### 3. APPEARANCE

There shall be no such details as discoloration or electrolyte leakage or 0 voltage.

### 4. RATINGS

Description	Unit	Specification	Condition
Nominal Voltage	V	1.2	Unit cell
Typical Capacity	min	315	Standard Charge/Discharge
Nominal Capacity	mAh	3000	Standard Charge/Discharge
Minimum Capacity	min	300	Standard Charge/ Discharge
Standard Charge	mA	300(0.1C)	Ta=0~40°C (see note )
	hour	16	
Fast Charge	mA	600(0.2C) with charge termination control	-ΔV=5mV/cell Timer cutoff=110%input capacity Temp. cutoff=40~45°C dT/dt=0.8°C/min(0.5 to 1.0C); 0.8~1°C/min(1C)
	hour	6.0 approx.(0.2C)	
Trickle Charge	mA	60(0.02C)~150(0.05C)	Ta=0~40°C (see note 1)
Discharge Cut-off Voltage	V	1.0	Unit cell
Maximum Discharging Current	A	15 (5.0C)	Ta =0~50°C 0.8v cut off
Storage Temperature	°C	-20~+25(within 1 year) -20~+30(within 3 month) -20~+40(within 1 month) -20~+50(within 1 week)	*
Typical Weight	g	53.75 approx	*

# BELNIMHSC3000

## 1.2V 3000 mAh

### 5. PERFORMANCE

Before proceed the following tests, the cells should be discharged at 0.2C to 1.0V cutoff. Unless otherwise stated, tests should be done within one month of delivery under the following conditions:

Ambient temperature:  $20^{\circ}\text{C} \pm 5^{\circ}\text{C}$

Relative Humidity:  $65 \pm 20\%$

Note Standard Charge/Discharge Conditions:

Charge:  $300 \text{ mA}(0.1\text{C}) \times 16\text{hrs}$

Discharge:  $600\text{mA}(0.2\text{C})$  to 1.0V/cell

Test	Unit	Specification	Condition	Remarks
Capacity	min	$\geq 300$	Standard Charge / Discharge	Up to 3 cycles are allowed
Open circuit Voltage (OCV)	V	$\geq 1.25$	Within 1 hr after standard charge	Unit cell
Internal Impedance (Ri)	m $\Omega$	$\leq 10$	Upon fully charge at 1kHz	*
High Rate Discharge (5.0C)	min	N/A	Standard Charge/rest 30min discharge at 5.0C to 0.8V/cell	*
Low Temperature Discharge	min	$\geq 240$	Standard Charge, Storage:24hrs at $0 \pm 2^{\circ}\text{C}$ 0.2C discharge at $0 \pm 2^{\circ}\text{C}$	1.0V/cell Cut-off
Overcharge	N/A	No conspicuous deformation and/or leakage	0.1C charge for 48hrs	*
Charge Retention	min	$\geq 180\text{min}$	Standard charge Storage: 28 days Standard discharge (0.2C)	1.0V/cell Cut-off
IEC Cycle Life Test	Cycle	$\geq 500$	IEC61951-2 ED3.0	*
Humidity	N/A	No leakage	Standard charged, stand for 14 days at $33 \pm 3^{\circ}\text{C}$ and $80 \pm 5\%$ of relative humidity	*

# BELNIMHSC3000

## 1.2V 3000 mAh

External Short Circuit	N/A	No fire and no explosion	After standard charge, short-circuit the cell at $20^{\circ}\text{C}\pm 5^{\circ}\text{C}$ until the cell temperature returns to ambient temperature.(cross section of the wire or connector should be more than $0.75\text{mm}^2$ )	*
Safety Device Operation	N/A	No explosion	Forced discharge at 0.2C to a final voltage of 0V,then the current be increased to 1C and forced discharge continue for 60 min	Leakage of electrolyte and Deformation are acceptable
Free falling(drop)	N/A	$\Delta V < 0.02\text{V}/\text{cell}$ $\Delta Ri < 5\%/\text{cell}$	Charge at 0.1C for 16hrs,and then leave for 24hrs,check battery before / after drop Height: 50 cm Thickness of wooden board: 30mm Direction is not specified Test for 3 times	*

Notes:

1. Ta:  
Ta: Ambient Temperature
2. Approximate charge time from discharged state, for reference only.
- 3.

Please activate the battery once every 3 months according to the following method. Otherwise, may cause the battery capacity attenuation, reducing the battery service life and so on.

Charge at 0.1C for 16 hrs, rest 10 min, then discharge with 0.2C to 1.0V/cell,rest 10 min, then charge at 0.2C to 150min.

**6. PRECAUTIONS TO ENSURE THE SAFETY ON BANDING BATTERY**

1.

Batteries should be charged prior to use.

2.

.When using a new battery for the first time or after long term storage, please fully charge the battery before use.

3.

For charging methods please reference to our technical handbook.

4.

Use the correct charger for Ni-Cd or Ni-MH batteries.

5.

Do not reverse charge batteries.

6.

Do not short circuit batteries, permanent damage to batteries may result.

7.

Do not incinerate or mutilate batteries, may burst or release toxic material.

8.

Do not solder directly to cells or batteries.

9.

Do not subject batteries to adverse condition such as extreme temperature, deep cycling and excessive overcharge/overdischarge.

10.

Store batteries in a cool dry place.

11.

Do not mix FBTECH batteries with other battery brands or batteries of a different chemistry such as alkaline and zinc carbon.

12.

Do not mix new batteries in use with semi-used batteries, over-discharge may occur.

13.

Avoid batteries being used in an airtight compartment. Ventilation should be provided inside the battery compartment; otherwise batteries may generate hydrogen gas, which could cause an explosion if exposed to an ignition source.

14.

# BELNIMHSC3000

## 1.2V 3000 mAh

When connecting a battery pack to a charger, ensure correct polarity.

15.

If find any noise, excessive temperature or leakage from a battery, please stop its use.

16.

When the battery is hot, please do not touch it and handle it, until it has cooled down.

17.

Do not remove the outer sleeve from a battery pack nor cut into its housing.

18.

When find battery power down during use, please switch off the device to avoid overdischarge.

19.

When not using a battery, disconnect it from the device.

20.

Unplug a battery by holding the connector itself and not by pulling at its cord.

21.

After use, if the battery is hot, before recharging it, allow it to cool in a well-ventilated place out of direct sunlight.

22.

Never put a battery into water or seawater.

23.

During long term storage, battery should be charged and discharged once every 3 months

24.

Do not attempt to take batteries apart or subject them to pressure or impact. Heat may be generated or fire may result. The alkaline electrolyte is harmful to eyes and skin, and it may damage clothing upon contact.

25.

Keep away from children. If swallowed, contact a physician at once.

26.

Battery failure, may not be thrown away, please recycling

27.

Stored or transport, please let the battery apart and fixed, to prevent external short circuit

7.

### Append: IEC61951-2 ED3.0 Endurance in cycles

Before the endurance in cycles test, the cell shall be discharged at 0.2 I<sub>r</sub>A to a final voltage of 1.0V/cell. The following endurance test shall then be carried out, irrespective of cell designation, in an ambient temperature of 20°C ± 5°C. Charge and discharge shall be carried out at constant current throughout, using the conditions specified in table 5. Precautions shall be taken to prevent the cell-case temperature from rising above 35°C during the test, by providing a forced air draught if necessary.

NOTE-Actual cell temperature, not the ambient temperature, determines cell performance.

**Table 5-Endurance in cycles**

Cycle number	Charge	Stand in Charged condition	Discharge
1	0.1 C <sub>r</sub> A for 16 h	None	0.25 C <sub>r</sub> A for 2 h 20 min <sup>2)</sup>
2 to 48	0.25 C <sub>r</sub> A for 3 h 10 min	None	0.25 C <sub>r</sub> A for 2 h 20 min <sup>2)</sup>
49	0.25 C <sub>r</sub> A for 3 h 10 min	None	0.25 C <sub>r</sub> A to 1.0V/cell
50	0.1 C <sub>r</sub> A for 16 h	1h to 4h	0.2 C <sub>5</sub> A to 1.0V/cell
<ul style="list-style-type: none"> <li>● It is permissible to allow sufficient open-circuit rest time after the completion of discharge at cycle 50, so as to start cycle 51 at an exact two-week interval. A similar procedure may be adopted at cycles 100, 150, 200, 250, 350, 400 and 450.</li> <li>● If cell discharge voltage drops below 1.0V/cell, discharge may be discontinued.</li> </ul>			

Cycles 1 to 50 shall be repeated until the discharge duration on any 50<sup>th</sup> cycle becomes less than 3h at this stage, a further cycle as specified for cycle 50 shall be carried out.

The endurance test is considered complete when two such successive cycles give a discharge duration less than 3h. The number of cycles obtained when the test is completed shall be not less than 500.