

EKSA Telecom

H1

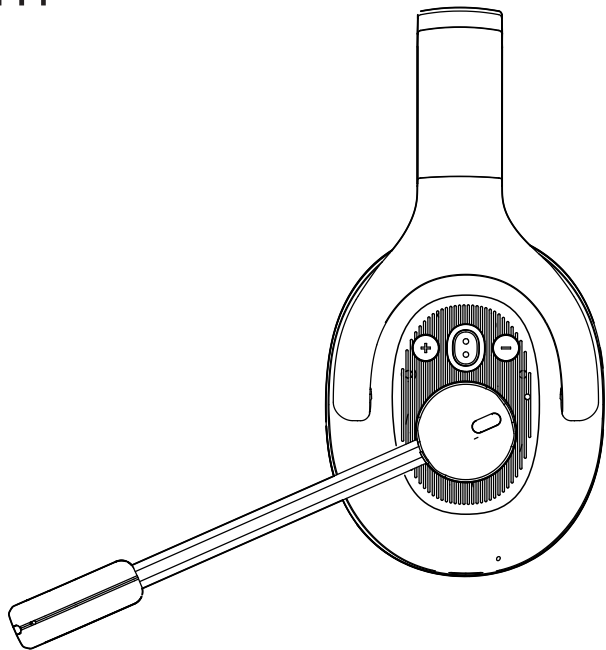

User Manual



Language Guide

English **1**

日本語 **9**

Français **17**

Deutsch **25**

Español **33**

italiano **41**



Packing List

1. EKSA H1 Headset
2. Charging Cable
3. Carry Pouch
4. User Manual



①



②



③



④



Specification



Bluetooth version: V5.0

Effective wireless range: 30 M/ 99ft



Music time: \approx 57 hours (70% volume)

Talk time: \approx 30 hours (70% volume)

Charging time: \approx 1.5 hours



Driver diameter: 40mm

Impedance: $32\Omega \pm 15\%$

Sensitivity: 114dB \pm 3dB

Frequency: 20Hz~20kHz



Diameter: $\varnothing 2.7 \times 1.85$ mm

Sensitivity: -25 \pm 1dB

Frequency: 100Hz~10KHz

Impedance: 2.2k Ω







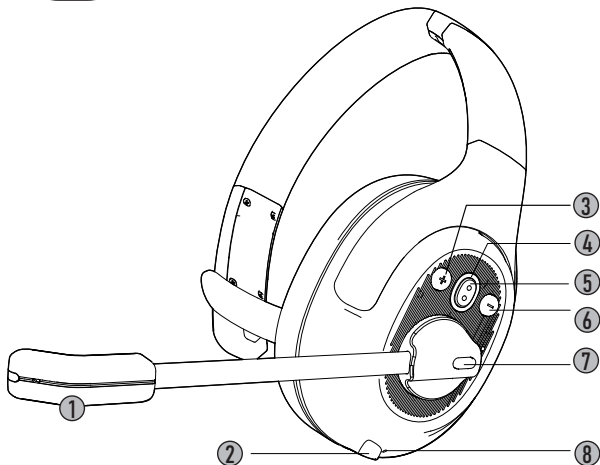

Polar Pattern: Omnidirectional

MIC: ENC (Environment Noise Canceling)



Product Overview



- ①  AI ENC microphone
- ②  Type-C charging port
- ③  Volume+
- ④  Bluetooth indicator
- ⑤  MFB (Multi-Function Button)
- ⑥  Volume-
- ⑦  Mic Mute Button
- ⑧  Charging indicator



Operation Guide



Multi-Function Button:



Press for 3 seconds: Turn on/off



Click: Pause/Play



Triple Click: Voice Assistant/Siri

Voice assistant



Volume Button:



Click: Volume+/-



Press for 2 seconds to next/previous track



MIC Mute Button:



Click: MIC on/off



Call Functions

Call Handling:

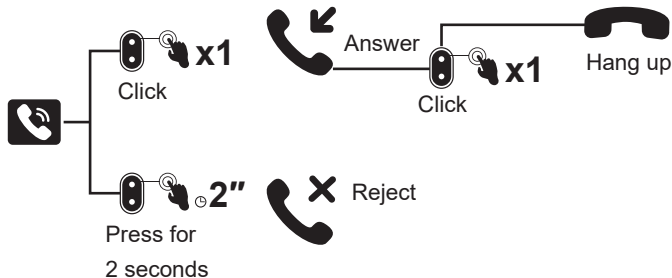

Redial:

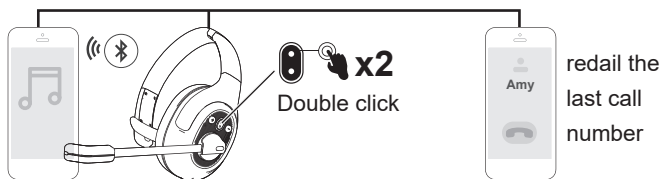

Audio switching:

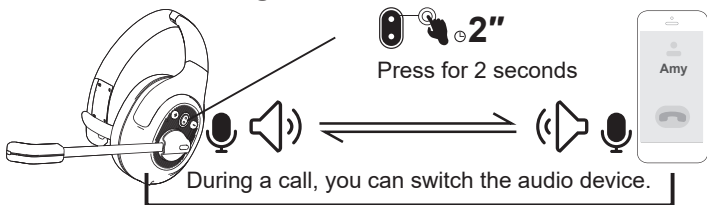



Call Functions



New call:

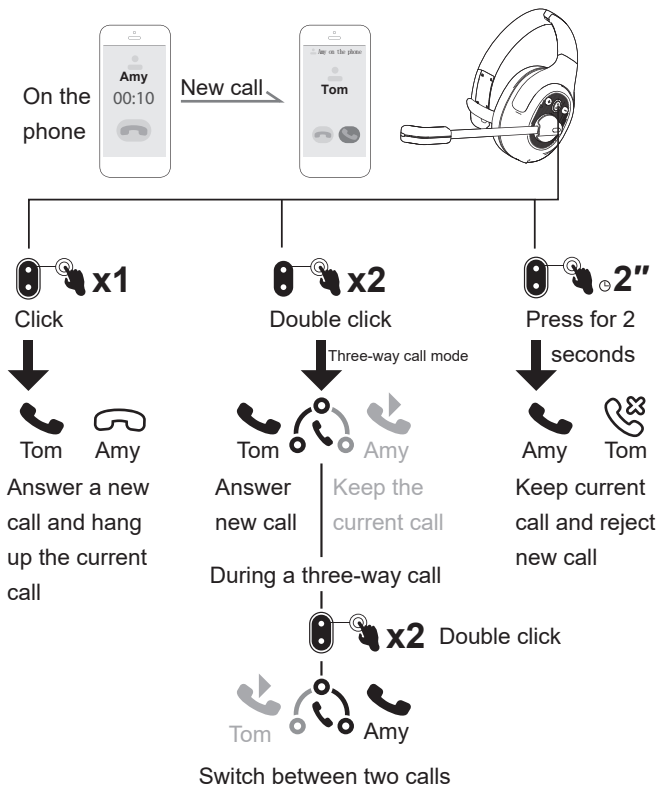



Bluetooth Pairing

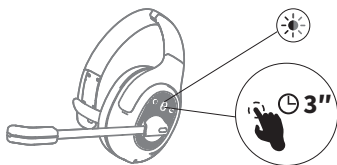

1. Turn on the headset, the bluetooth indicator flashes alternately in red and blue, indicating that the headset is in pairing state.

2. Turn on the Bluetooth of the device and select "EKSA H1". After successful connection, the LED flashes slowly in blue light, and you will hear the voice prompt "your headset is connected".

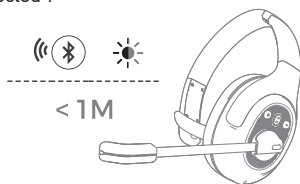
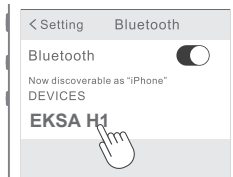

Note:

1. When connecting the device, please keep the headset and the device within 1 meter.
2. If necessary, the PIN code is "0000".
3. If there is no connection with any device for 10 minutes, the headset will automatically shut down.
4. After the headset is turned on, it will automatically connect back to the last connected device.

3. When connecting to a new device, turn off the Bluetooth of the currently connected device and then confirm that the headset enters the Bluetooth pairing state.

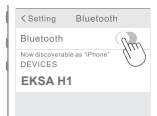

Device 1

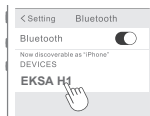

Device 2





Dual Pairing

1. After successfully connecting the headset to device A, turn off the Bluetooth of device A. The headset Bluetooth indicator flashes in red and blue alternately to enter the pairing state.

Device A

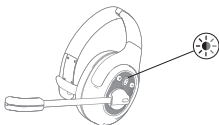

2. Turn on device B, search for and connect to EKSA H1.



Device B

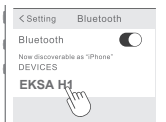

Device B



3. Turn on the Bluetooth A device to connect with EKSA H1. After connection, the EKSA H1 and the devices A and B are in the connected state simultaneously.

Device A



Reset

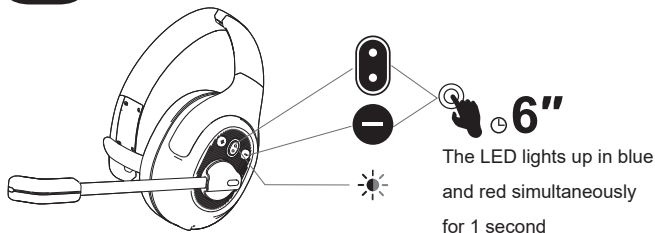

Under connected/pairing state, press the "MFB" and the "volume-" for 6 seconds simultaneously until the LED lights up in blue and red simultaneously for 1 second, indicating the pairing information is cleared.

Charging

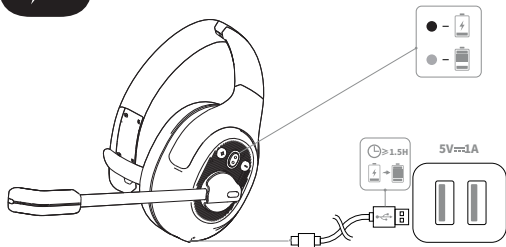

1. When battery is less than 10%, the headset will voice prompt "battery low" every 3 minutes, please charge it as soon as possible.
2. When EKSA H1 is not in use, please charge it at least one time every 2 months.
3. Please use the original charging cable for charging. Charging voltage can't exceed 5V.



パッケージ内容

1. ヘッドセット本体
2. Type-C充電ケーブル
3. キャリーポーチ
4. 取扱説明書



①



②

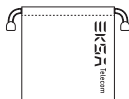

③



④



仕様



Bluetooth V5.0

最大通信距離 約30m



音楽再生時間 約57時間(70%音量)

通話時間 約30時間(70%音量)

充電時間 約1.5H



スピーカーサイズ 40 mm

インピーダンス 32Ω±15%

スピーカー感度 114dB±3dB

周波数特性 20Hz-20KHz



寸法 ø2.7x1.85mm

インピーダンス -25±1dB

周波数特性 100Hz-10KHz

インピーダンス 2.2KΩ

指向性 無(全)指向性

MIC ENC (環境ノイズキャンセリング)



各部の名称

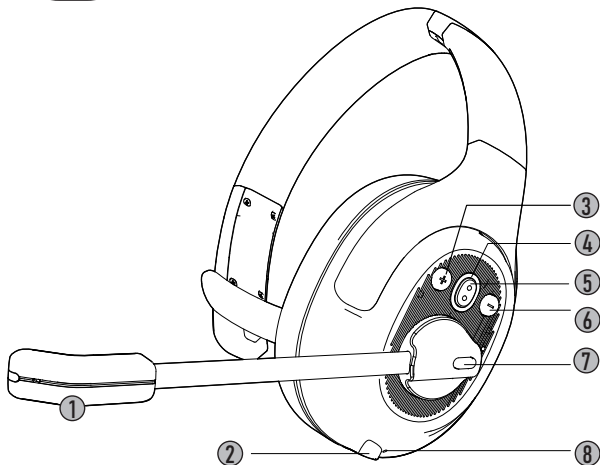

- ①  AI ENC マイク
- ②  Type-C充電ポート
- ③  音量+
- ④  ブルートゥースインジケータ
- ⑤  MFB(マルチファンクションボタン)
- ⑥  音量-
- ⑦  マイクミュートボタン
- ⑧  充電インジケータ



操作ガイド



マルチファンクションボタン:



3秒間長押し:電源を ON/OFF



1回クリック:一時停止/再生



3回トリプルクリック:音声アシスタント/
Siriを起動します

音声アシスタント

+ / - 音量ボタン:



1回クリック:音量+/-



2秒間長押し:曲送り/曲戻し



MICミュートボタン:



1回クリック:マイクミュート
ON/OFF



通話機能

通話管理:

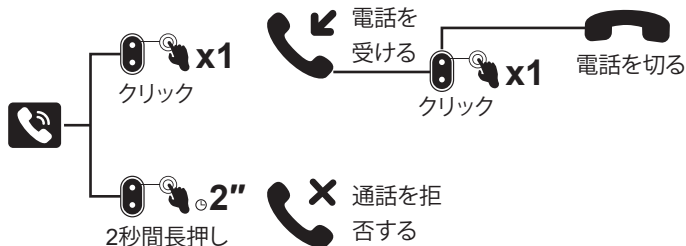

リダイヤル:



オーディオスイッチング:

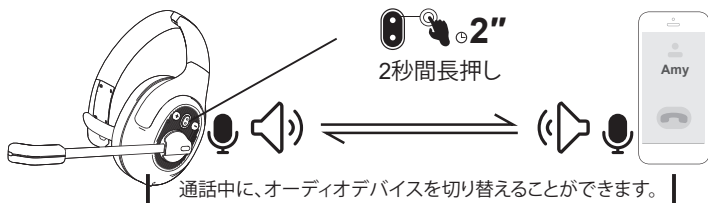



通話機能

📞 新しい呼び出し:

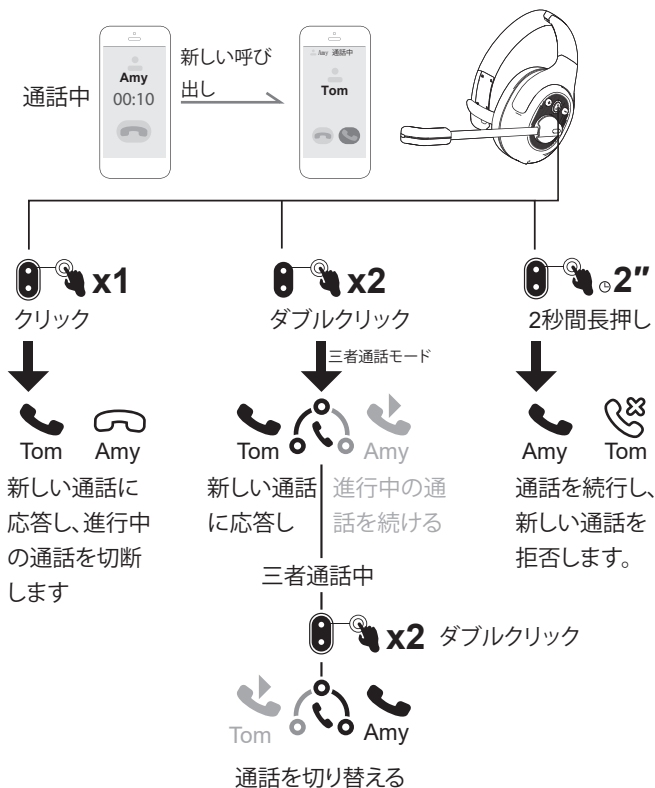



Bluetoothペアリング

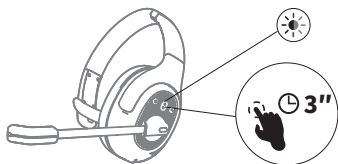

1. マルチファンクションボタンを3秒以上押し続けます。LEDランプが赤⇔青交互に点滅し、ペアリングモードになります。

2. 携帯電話やパソコンなどから本製品が見つかったら、デバイス名「EKSA H1」が検索画面上に表示されますので、ペアリング接続をクリックします。LEDランプが青色のゆるやかな点滅に変わると、「your headset is connected」の音声を出て来て、ペアリングが完了です。

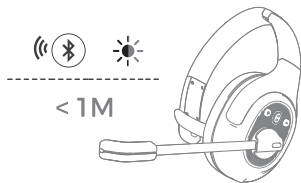
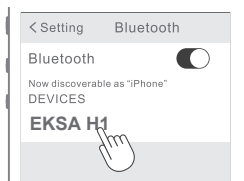

注意:



1. この手順を実行する時は、ヘッドホンがスマートフォンから1mの範囲内にあり、ヘッドセットでBluetoothRがアクティブになっていることを確認してください。
2. パスキーを要求された場合は0000を入力してください。
3. 10分間どのデバイスにも接続されていない場合、ヘッドセットは自動的にシャットダウンします。
4. 次回接続するときは本機の電源をオンにして、登録済みの機器のBluetooth機能をオンにするだけで接続できます。

3. 新しいデバイスに接続するときは、接続されているデバイスのBluetoothをオフにしてから、ヘッドセットがBluetoothペアリング状態になっていることを確認してください。

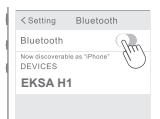

デバイス1



デバイス2





2台同時接続

1. ヘッドセットをデバイスAに接続したら、デバイスAのBluetoothをオフにします。ヘッドセットのBluetoothインジケータが赤と青に交互に点滅して、ペアリング状態になります。



2. デバイスBのBluetoothをONにします。EKSA H1を検索して接続します。

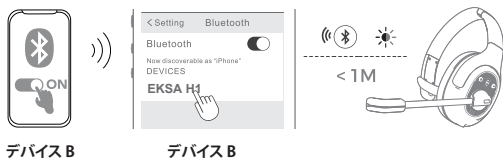

3. デバイスAのBluetoothをオンにして、EKSA H1に接続します。接続後、EKSA H1とデバイスAおよびBは同時に接続状態になります。

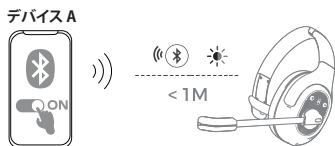

リセット

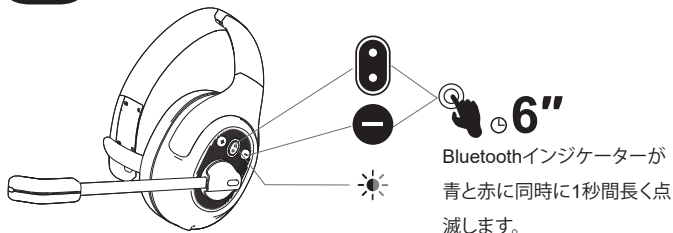

接続/ペアリング状態で、「MFB」と「ボリューム-」を同時に6秒間長押し、LEDが青と赤で同時に1秒間点灯します。これは、ペアリング情報がクリアされたことを意味します。

充電する

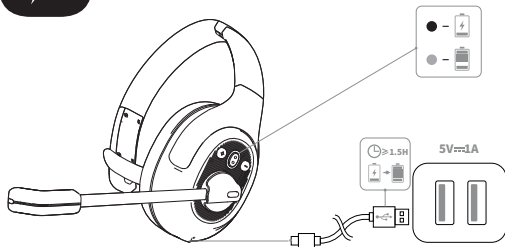

1. バッテリーが10%未満の場合、ヘッドセットは三分間ごとに「battery low」の音声プロンプトを発します。できるだけ早く充電してください。
2. ヘッドセットを長期間使用しない場合は、2か月に1回ヘッドセットを充電してください。
3. 充電には付属のUSB充電ケーブルを充電してください。



Contenu du Product

1. EKSA H1 Casque
2. Câble de Charge de Type C
3. Sac d'Emballage
4. Manuel d'Utilisation

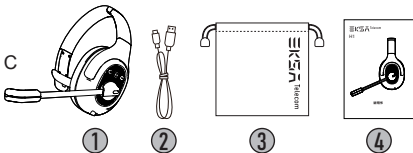

Spécification



Version Bluetooth: V5.0

Portée Sans Fil: 30 M/99ft



Temps de musique: \approx 57 heures (70% volume)

Temps de Conversation: \approx 30 heures (70% volume)

Temps de Charge: 1.5 heures



Diamètre du haut-parleur: 40mm

Impédance: $32\Omega \pm 15\%$

Sensibilité: $114\text{dB} \pm 3\text{dB}$

Fréquence: 20Hz~20kHz



Diamètre: $\varnothing 2.7 \times 1.85\text{mm}$

Sensibilité: $-25 \pm 1\text{dB}$

Fréquence: 100Hz~10KHz

Impédance: $2.2\text{k}\Omega$







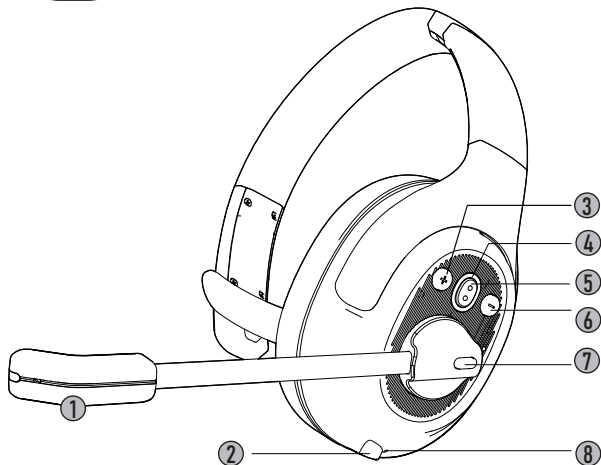

Direction: Omnidirectionnel

Mic: ENC (Réduction du Bruit)



Aperçu



- ①  AI ENC microphone
- ②  Port de Charge de Type-C
- ③  Volume+
- ④  Voyant de bluetooth
- ⑤  MFB (Bouton multifonction)
- ⑥  Volume-
- ⑦  Bouton de Sourdine d'MIC
- ⑧  • Voyant de charge



Guide d'Opération



Bouton Multifonction:



Appuyez longuement pendant 3 secondes: Allumer/Eteindre



Cliquer: Jouer/Pause



SIRI: Cliquez trois fois de suite

SIRI



Button Volume:



Cliquer: Volume+/-



Appuyez longuement pendant 2 secondes: Piste suivante/Piste précédente



Bouton de Sourdine d'MIC:



Cliquer: MIC Allumer/Couper



Fonction d'Appel

Traitement des appels:

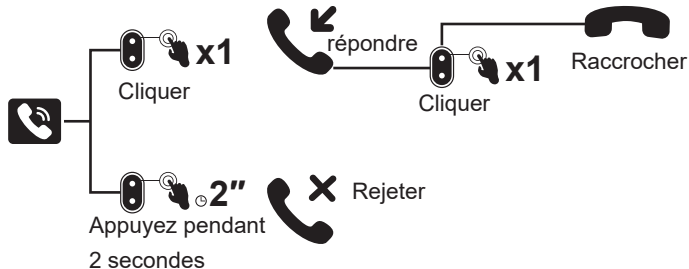

Rappeler:

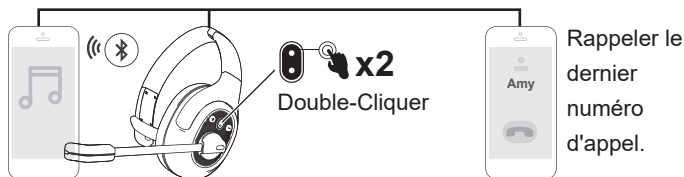

Commutation audio:

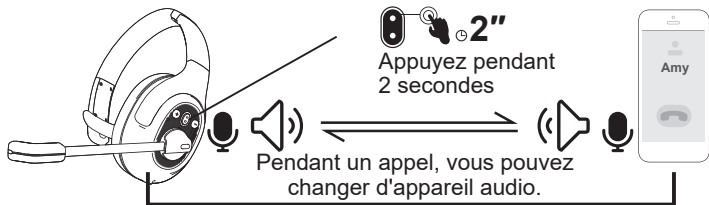



Fonction d'Appel



Nouvel appel:

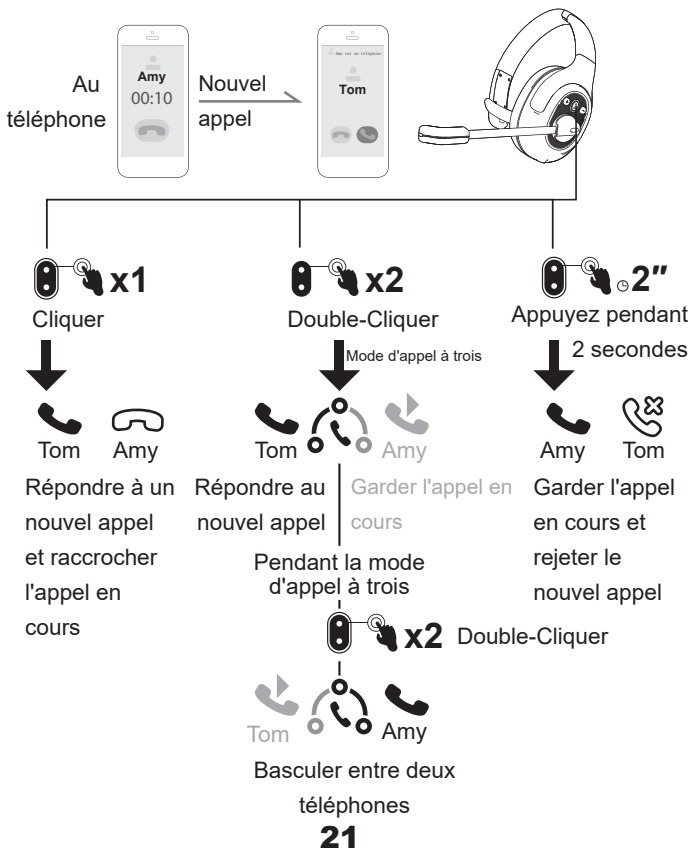



Appariement Bluetooth

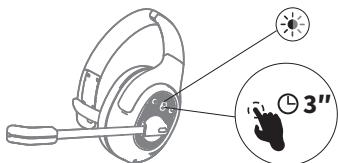

1. Allumez le casque, le voyant de Bluetooth du casque clignote alternativement en rouge et bleu, ce qui signifie que il est en paire.

2. Activez le Bluetooth de l'appareil et sélectionnez "EKSA H1". Après la connexion réussie, le voyant de Bluetooth clignote lentement en lumière bleue et vous entendrez l'invite vocale "your headset is connected".

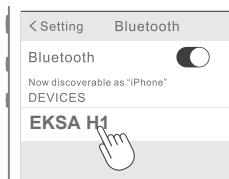

*Remarque:

1. Lors de la connexion de l'appareil, veuillez garder le casque et l'appareil à moins de 1 mètre.
2. Si nécessaire, le code PIN est "0000".
3. S'il n'y a aucune connexion avec un appareil pendant 10 minutes, le casque s'éteindra automatiquement.
4. Une fois le casque allumé, il se reconnectera automatiquement au dernier appareil connecté.*

3. Lors de la connexion à un nouvel appareil, désactivez le Bluetooth de l'appareil actuellement connecté, puis confirmez que le casque passe à l'état de couplage Bluetooth.

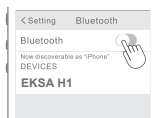

Appareil 1



Appareil 2





Deux Paires

1. Après avoir réussi à connecter le casque à l'appareil A, désactivez le Bluetooth de l'appareil A. L'indicateur Bluetooth du casque clignote alternativement en rouge et en bleu pour entrer dans l'état de couplage.

Phone A

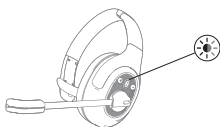

2. Allumez l'appareil B, recherchez et connectez-vous à EKSA H1.



Phone B

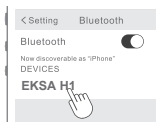

Phone B



3. Allumez le périphérique Bluetooth A pour vous connecter avec EKSA H1. Après la connexion, EKSA H1 et les appareils A et B sont à l'état connecté simultanément.

Phone A





Réinitialisation

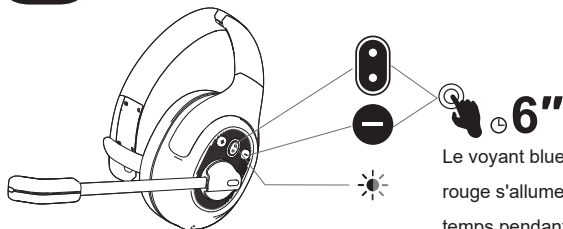

Le voyant bluetooth bleu et rouge s'allume en même temps pendant 1 seconde.

Dans l'état connecté/d'appariement, appuyez sur le "MFB" et le "volume-" pendant 6 secondes simultanément jusqu'à ce que le voyant s'allume en bleu et en rouge simultanément pendant 1 seconde, indiquant que les informations d'appariement sont effacées.



Recharger

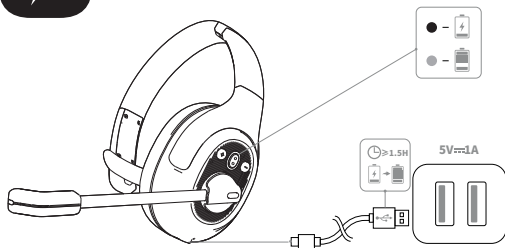

1. Lorsque la batterie du casque est inférieure à 10%, le casque annonce "battery low" toutes les 3 minute, veuillez le charger dès que possible.
2. Si le casque n'est pas utilisé pendant une longue période, veuillez charger le casque une fois tous les deux mois.
3. Veuillez utiliser le câble de charge d'origine pour la charge. La tension de charge ne peut pas dépasser 5V.



Packliste

1. EKSA H1 Kopfhörer
2. Ladekabel
3. Tragetasche
4. Benutzerhandbuch



①



②

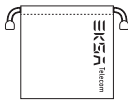

③



④



Spezifikation



Bluetooth-Version: V5.0

Effektive Funkreichweite: 30 m/99ft



Musikzeit: \approx 57 Stunden (70% Lautstärke)

Gesprächszeit: \approx 30 Stunden (70% Lautstärke)

Ladezeit: \approx 1.5 Stunden



Treiberdurchmesser: 40mm

Impedanz: $32\Omega \pm 15\%$

Empfindlichkeit: 114dB \pm 3dB

Frequenz: 20Hz~20kHz



Durchmesser: \varnothing 2.7x1.85mm

Empfindlichkeit: -25 \pm 1dB

Frequenz: 100Hz~10KHz

Impedanz: 2.2 k Ω





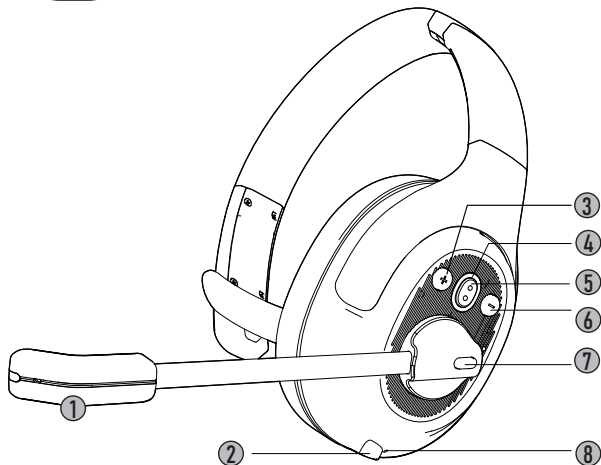

Ausrichtung: Omnidirektional

Mikrofon: ENC (Environment Noise Canceling)



Produkt Anzeige



- ①  AI ENC-Mikrofon
- ②  Typ-C-Ladeanschluss
- ③  Lautstärke+
- ④  Bluetooth-Anzeige
- ⑤  MFB (Multi-Function Button)
- ⑥  Lautstärke-
- ⑦  Mikrofon-Stummschalttaste
- ⑧  Ladeanzeige



Bedienerführung



MFB:



3 Sekunden drücken: Ein/Aus



Klicken: Pause/Spielen



Dreifachklick: Sprachassistent/Siri

Sprachassistent



Lautstärke Taste:



Klicken: Lautstärke+/-



2 Sekunden drücken: Nächster/Vorheriger Artikel



Mikrofon-Stummschalttaste



Klicken: Mikrofon Ein/Aus



Anruffunktionen

Anrufbearbeitung:

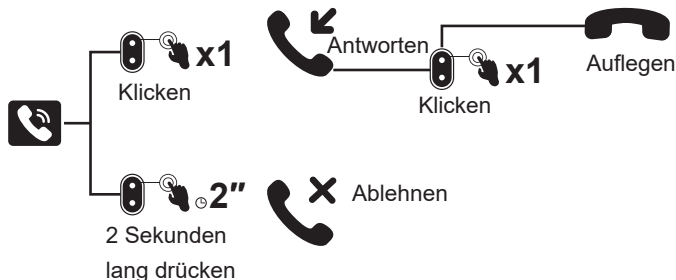

Wahlwiederholung:

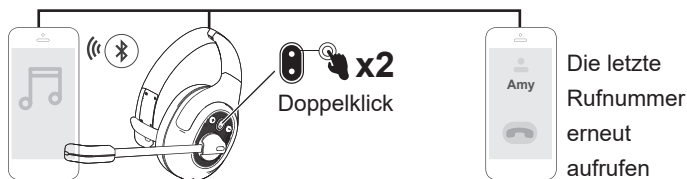

Audioumschaltung:

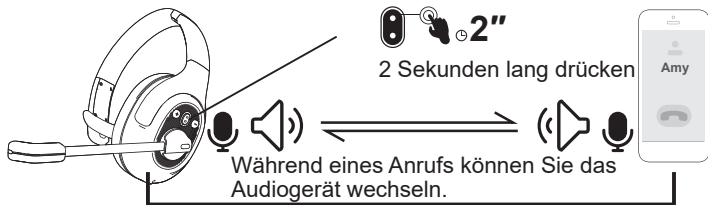



Anruffunktionen

Neuer Anruf:

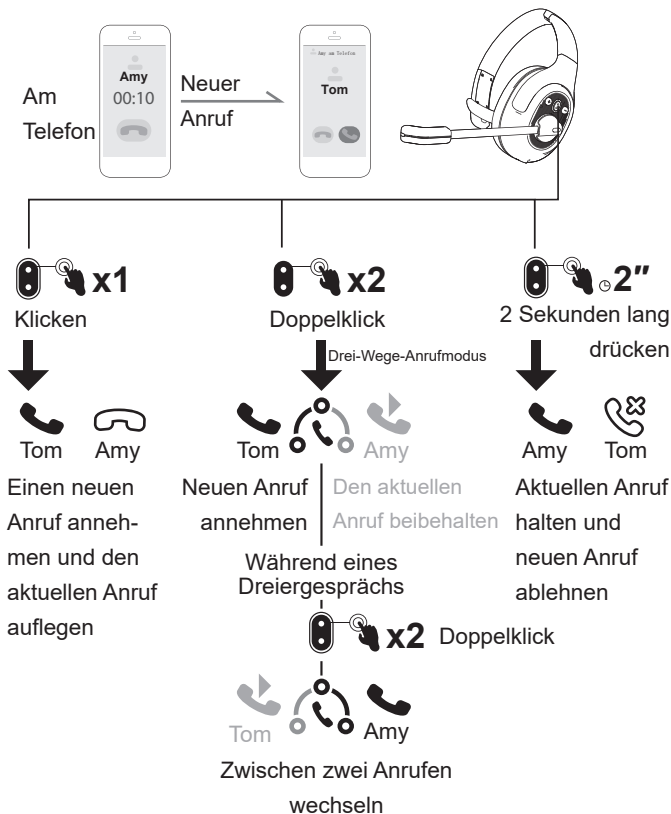



Bluetooth-Kopplung

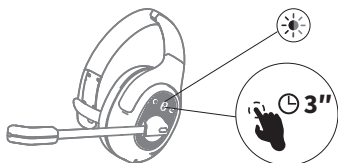

1. Das Headset einschalten, die Bluetooth-Anzeige blinkt abwechselnd rot und blau und zeigt damit an, dass sich das Headset im Pairing-Zustand befindet.

2. Das Bluetooth des Geräts einschalten und „EKSA H1“ wählen. Nach erfolgreicher Verbindung blinkt die LED langsam blau und Sie hören die Sprachansage „your headset is connected“.

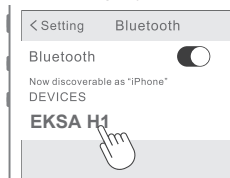

“Hinweis:

1. Halten Sie beim Anschließen des Geräts das Headset und das Gerät innerhalb von 1 Meter.
2. Bei Bedarf lautet der PIN-Code “0000”.
3. Wenn 10 Minuten lang keine Verbindung zu einem Gerät besteht, wird das Headset automatisch heruntergefahren.
4. Nachdem das Headset eingeschaltet wurde, verbindet es sich automatisch wieder mit dem zuletzt verbundenen Gerät.”

3. Wenn Sie eine Verbindung zu einem neuen Gerät herstellen, schalten Sie das Bluetooth des aktuell verbundenen Geräts aus und bestätigen Sie dann, dass das Headset in den Bluetooth-Kopplungsstatus wechselt.

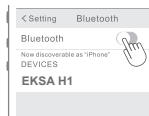

Gerät 1

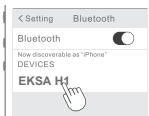

Gerät 2





Dual Pairing

1. Nach der erfolgreichen Verbindung mit Gerät A, Bluetooth von Gerät A ausschalten. Die Bluetooth-Anzeige blinkt abwechselnd rot und blau, um in den Kopplungsstatus zu wechseln.

Gerät A



2. Bluetooth von Gerät B einschalten, nach EKSA H1 suchen und damit verbinden.



Gerät B

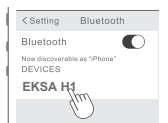

Gerät B



3. Bluetooth von Gerät A einschalten, um eine Verbindung mit dem EKSA H1 herzustellen. Nach dem Anschließen befinden sich der EKSA H1 und die Gerät A und B gleichzeitig im verbundenen Zustand.

Gerät A





Zurücksetzen

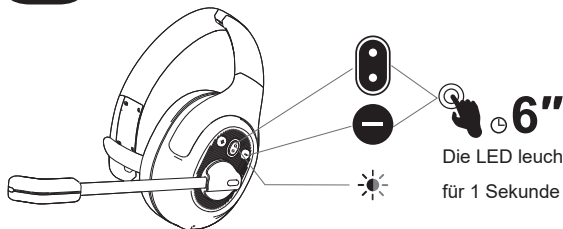

Die LED leuchtet gleichzeitig für 1 Sekunde blau und rot.

Im Verbindungs-/Pairing-Zustand gleichzeitig die "MFB" und die "Lautstärke-" für 6 Sekunden drücken, bis die LED gleichzeitig 1 Sekunde lang blau und rot aufleuchtet, um anzuzeigen, dass die Kopplungsinformationen gelöscht sind.



Aufladen

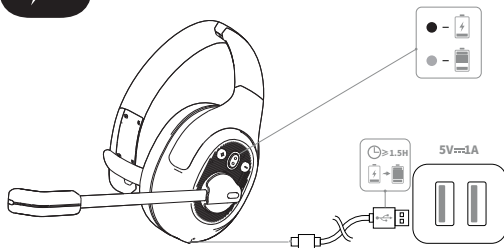

1. Wenn der Akku weniger als 10% beträgt, gibt das Headset alle 3 Minuten die Sprachansage "battery low" aus. Bitte laden Sie es so schnell wie möglich auf.
2. Wenn EKSA H1 nicht verwendet wird, laden Sie es bitte alle 2 Monate auf.
3. Bitte verwenden Sie zum Aufladen das Original-Ladekabel. Die Ladespannung darf 5V nicht überschreiten.



Lista de Empaque

1. Auriculares EKSA H1
2. Cable de Carga
3. Bolsa de Transporte
4. Manual de Usuario

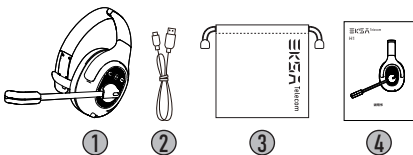

Especificación



Versión de Bluetooth: V5.0

Alcance inalámbrico efectivo: 30 M / 99 ft



Tiempo de música: \approx 57 horas (70% de volumen)

Tiempo de conversación: \approx 30 horas (70% volumen)

Tiempo de carga: \approx 1,5 horas



Diámetro del Conductor: 40 mm

Impedancia: $32\Omega \pm 15\%$

Sensibilidad: $114\text{dB} \pm 3\text{dB}$

Frecuencia: 20 Hz ~ 20 kHz



Diámetro: $\varnothing 2.7 \times 1.85\text{mm}$

Sensibilidad: $-25 \pm 1\text{dB}$

Frecuencia: 100 Hz ~ 10 KHz

Impedancia: 2,2 k Ω







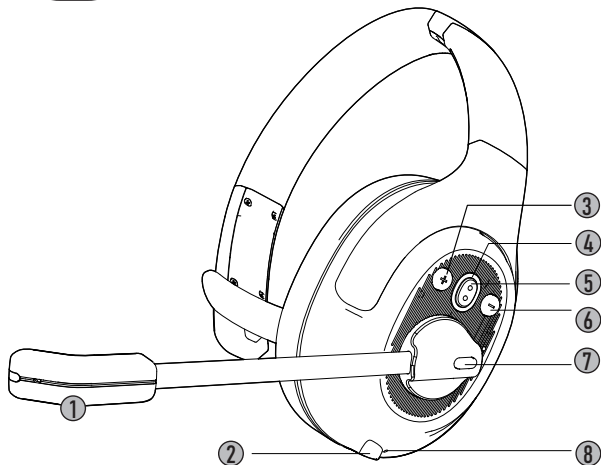

Patrón Polar: Omnidireccional

MIC: ENC (Cancelación de Ruido Ambiental)



Pantalla del Producto



- ①  Micrófono AI ENC
- ②  Puerto de carga Tipo C
- ③  Volumen +
- ④  Indicador de bluetooth
- ⑤  MFB (Botón Multifunción)
- ⑥  Volumen-
- ⑦  Botón de Silencio del Micrófono
- ⑧  • Indicador de carga



Manual de Operaciones



Botón multifunción:



Presione durante 3 segundos:
encender / apagar



Haga clic: Pausar / Reproducir



Asistente de voz: triple clic para
activar el asistente de voz / Siri

SIRI



Botón de Volumen:



Haga clic: Volumen +/-



Presione durante 2 segundos para ir a la pista anterior
o siguiente.



Botón de Silencio del Micrófono:



Haga clic: MIC on / off



Funciones de Llamada

Manejo de Llamadas:

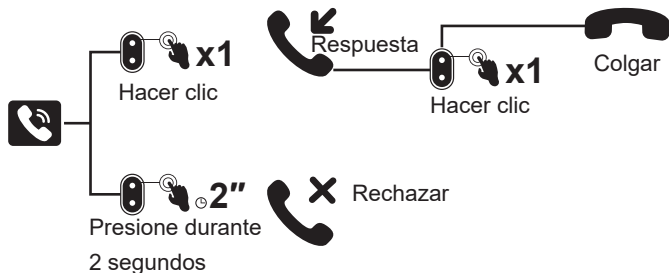

Volver a marcar:

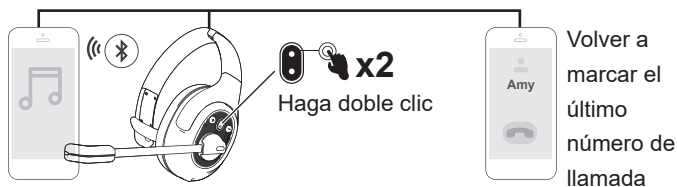

Conmutación de audio:

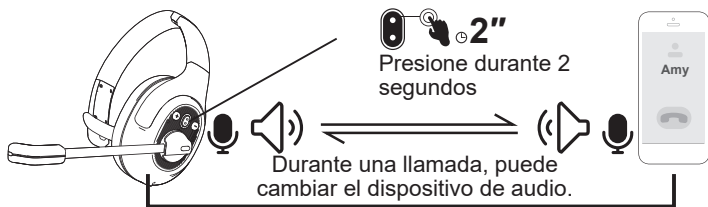



Funciones de Llamada



Nueva llamada:

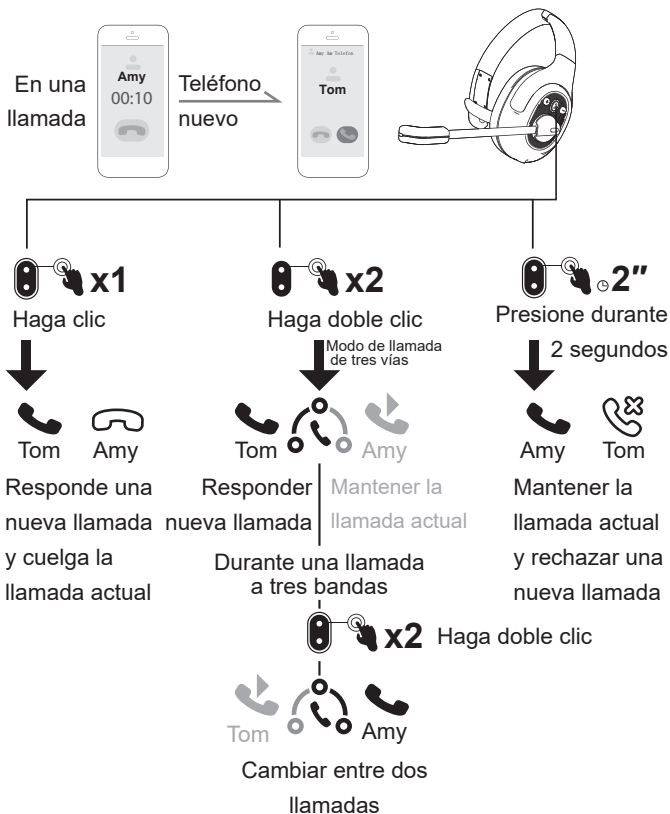



Emparejamiento Bluetooth

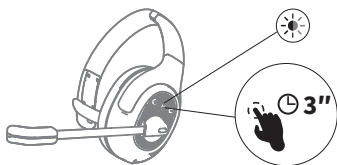

1. Encienda el auricular, el indicador de bluetooth parpadea alternativamente en rojo y azul, lo que indica que el auricular está en estado de emparejamiento.

2. Encienda el Bluetooth del dispositivo y seleccione "EKSA H1". Después de una conexión exitosa, el LED parpadea lentamente con luz azul y escuchará el mensaje de voz "your headset is connected".

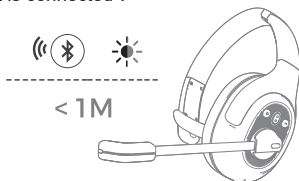
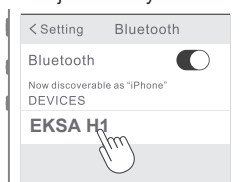

*Nota:

1. Cuando conecte el dispositivo, mantenga el auricular y el dispositivo a 1 metro.
2. Si es necesario, el código PIN es **** 0000 ****.
3. Si no hay conexión con ningún dispositivo durante 10 minutos, el auricular se apagará automáticamente.
4. Después de encender el auricular, se conectará automáticamente al último dispositivo conectado.*

3. Cuando conecte un nuevo dispositivo, apague el Bluetooth del dispositivo actualmente conectado y luego confirme que el auricular ingresa al estado de emparejamiento de Bluetooth.

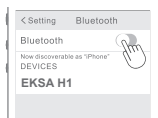

Device 1

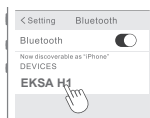

Device 2





Emparejamiento Dual

1. Después de conectar correctamente el auricular al dispositivo A, apague el Bluetooth del dispositivo A. El indicador de Bluetooth del auricular parpadea en rojo y azul alternativamente para ingresar al estado de emparejamiento.

Phone A

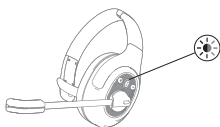

2. Encienda el dispositivo B, busque y conéctese a EKSA H1.



Phone B

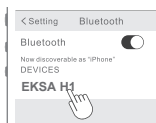

Phone B



3. Encienda el dispositivo Bluetooth A para conectarse con EKSA H1.

Después de la conexión, el EKSA H1 y los dispositivos A y B están en el estado conectado simultáneamente.

Phone A





Reiniciar

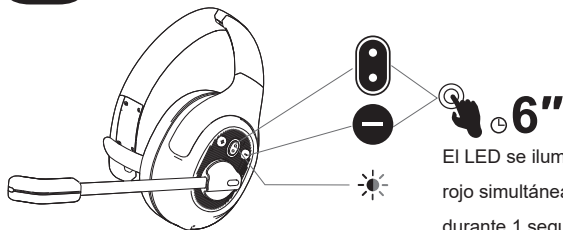

El LED se ilumina en azul y rojo simultáneamente durante 1 segundo.

En el estado de conexión / emparejamiento, mantenga presionado "MFB" y "Volumen -" al mismo tiempo durante 6 segundos, hasta que las luces LED azul y roja se enciendan durante 1 segundo al mismo tiempo, lo que indica que la información de emparejamiento se despejado.



Cargando

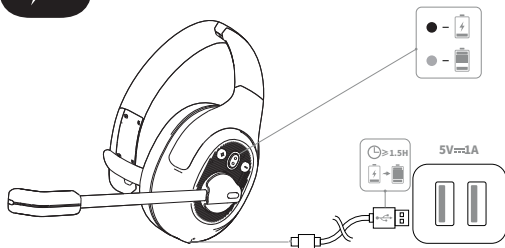

1. Cuando la carga de la batería sea inferior al 10%, el auricular le indicará por voz "battery low" cada 3 segundos, cárguelo lo antes posible.
2. Cuando el EKSA H1 no esté en uso, cárguelo al menos una vez cada 2 meses.
3. Utilice el cable de carga original para cargar. El voltaje de carga no puede exceder los 5V.



Lista dell'Imballaggio

1. EKSA Auricolare H1
2. Cavo di Ricarica
3. Borsa per Cuffia
4. Manuale dell'Utente



①



②

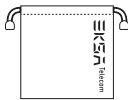

③



④



Specifiche



Versione di Bluetooth: V5.0

Portata wireless effettiva: 30 M



Tempo di musica: \approx 57 ore (volume 70%)

Tempo di conversazione: \approx 30 ore (volume 70%)

Tempo di ricarica: 1,5 ore



Diametro dell'altoparlante: 40 mm

Impedenza: $32\Omega \pm 15\%$

Sensibilità: $114\text{dB} \pm 3\text{dB}$

Frequenza: 20Hz~20kHz



Diametro: $\varnothing 2.7 \times 1.85\text{mm}$

Sensibilità: $-25 \pm 1\text{dB}$

Frequenza: 100Hz~10KHz

Impedenza: $2.2\text{k}\Omega$







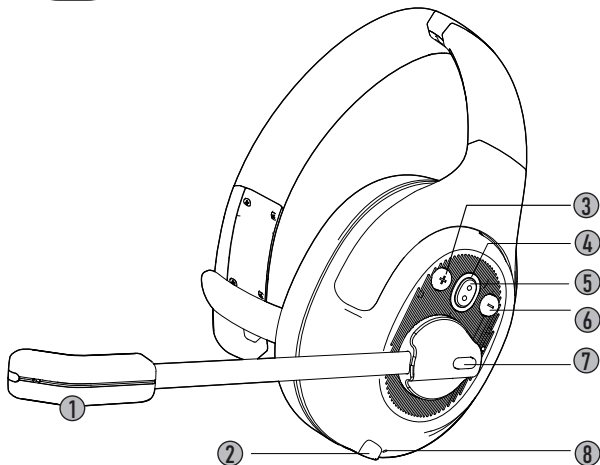

Direzione Polar: Omnidirezionale

MIC: ENC (Cancellazione del Rumore Ambientale)



Esposizione del Prodotto



- ①  Microfono con riduzione del rumore AI (ENC)
- ②  Porta di ricarica di Type-C
- ③  Volume+
- ④  Indicatore di Bluetooth
- ⑤  MFB (Pulsante Multifunzione)
- ⑥  Volume-
- ⑦  Pulsante di Disattivazione del Microfono
- ⑧  • Indicatore di ricarica



Guida Operativa



Pulsante Multifunzione:



Premere a lungo per 3s: Accendere/Spegnere



Fare un clic: Pausa/Riprodurre



Assistente vocale: Tre clic rapidi per attivare l'assistente vocale/Siri

l'assistente vocale



Pulsante del Volume:



Fare un clic: Volume+/-



Premere a lungo per 2s per passare alla traccia successiva/precedente



Pulsante di Disattivazione del Microfono:



Fare un clic: MIC acceso/spento



Funzioni di Chiamata

Gestione delle Chiamate:



Ricomposizione:

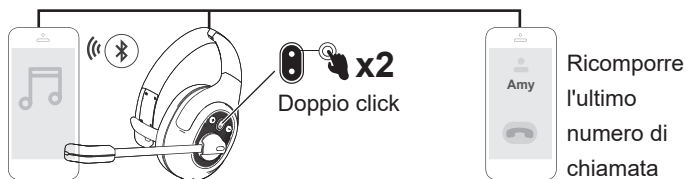

Commutazione di audio:

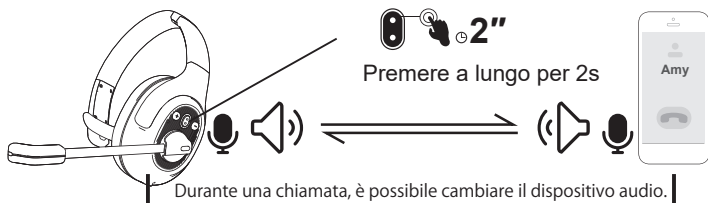



Funzioni di Chiamata

Nuova chiamata:

**Chiamata
in corso**

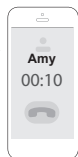

Nuova
chiamata

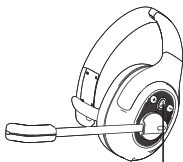

Fare un clic



Rispondere a
una nuova
chiamata e
riagganciare la
chiamata in
corso



Doppio click

Modalità di chiamata a tre



Rispondere a
una nuova
chiamata

Mantenere la
chiamata in corso

Durante una chiamata a tre



Doppio click



Passare da una chiamata all'altra



Premere a lungo per 2''



Mantenere la
chiamata in corso
e rifiutare la
nuova chiamata



Associazione di Bluetooth

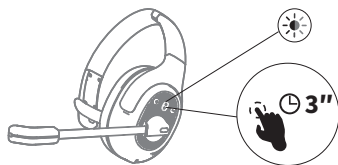

1. Accendere l'auricolare, l'indicatore di bluetooth lampeggia alternativamente in rosso e blu, indicando che l'auricolare è in stato di accoppiamento.

2. Attivare il Bluetooth del dispositivo e selezionare "EKSA H1". Dopo una connessione riuscita, l'indicatore di bluetooth lampeggia lentamente in luce blu e potrebbe sentire il messaggio vocale "Your headset is connected".

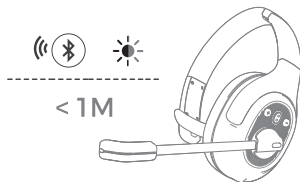
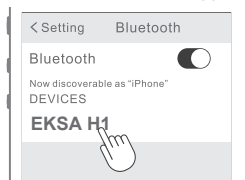

Nota:

1. Quando si collega il dispositivo, tenere l'auricolare e il dispositivo entro 1 metro.
2. Se necessario, il codice di PIN è "0000".
3. Se non c'è connessione con alcun dispositivo entro 10 minuti, l'auricolare si spegne automaticamente.
4. Dopo l'accensione, l'auricolare si riconnetterà automaticamente all'ultimo dispositivo connesso.

3. Quando ci si connette a un nuovo dispositivo, disattivare il Bluetooth del dispositivo attualmente connesso e poi confermare che l'auricolare entri nello stato di accoppiamento di Bluetooth.

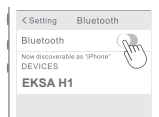

Dispositivo 1

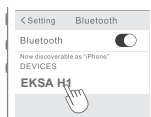

Dispositivo 2





Funzione Uno per Due

1. Dopo aver collegato correttamente l'auricolare al dispositivo A, disattivare il Bluetooth del dispositivo A. L'indicatore di Bluetooth dell'auricolare lampeggia alternativamente in rosso e blu per entrare nello stato di associazione.

Phone A

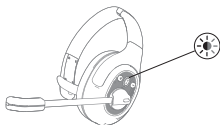

2. Accendere il dispositivo B, cercare e connettersi a EKSA H1.

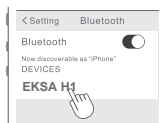

Phone B

Phone B

3. Accendere il Bluetooth del dispositivo A per connettersi con EKSA H1. Dopo la connessione, l'EKSA H1 e i dispositivi A e B sono nello stato connesso contemporaneamente.

Phone A





Ripristina

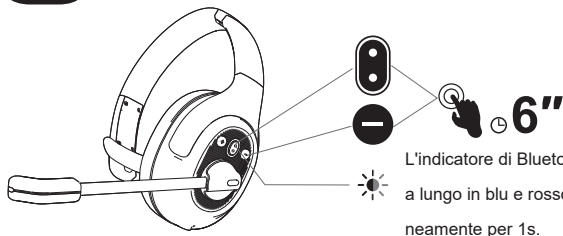

L'indicatore di Bluetooth lampeggia a lungo in blu e rosso contemporaneamente per 1s.

In stato di connessione/associazione, premere contemporaneamente "MFB" e "volume-" per 6s finché l'indicatore di Bluetooth si lampeggia a lungo in blu e rosso contemporaneamente per 1s, che significa le informazioni di associazione sono state cancellate.



Ricarica

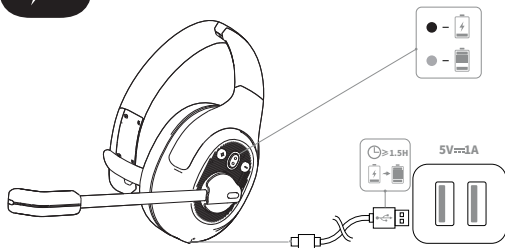

1. Quando la batteria è inferiore al 10%, l'auricolare emetterà un messaggio vocale "Battery low" per ogni 3s, si prega di ricaricarlo al più presto.
2. Se l'auricolare non viene utilizzato per un lungo periodo, si prega di ricaricare l'auricolare una volta ogni due mesi.
3. Utilizzare il cavo di ricarica originale per ricaricare. La tensione di uscita della testina di ricarica non può superare i 5V.

Limited Warranty/ Eingeschränkte Garantie 保証書 / Garantie limitée / Garantía limitada

Our friendly customer service team are ready and waiting to help. Here is how we can connect:

Unser freundliches Kundenservice-Team ist bereit, Ihnen zu bedienen. So können Sie uns kontaktieren:

私たちのカスタマーサービスチームはいつでもお手伝いします。連絡先は次のとおり:

Notre gentil service client est toujours à votre écoute. Vous pouvez nous contacter par une des manières suivantes :

Nuestro amable equipo de atención al cliente está listo y esperando para ayudar:

 **GLOBAL: +852 6940 4955 (Mon to Fri 9:00 am-6:30 pm, UTC +8 HKT)**
INDIA: +91-8929-369-620 (Mon to Fri IST 9:30 am-5:30 pm)

 **GLOBAL: info@eksatelecom.net**
INDIA: support@eksa.co.in

 **www.eksatelecom.com/pages/warranty**

EKSA Telecom