

• CARATTERISTICHE TECNICHE
TECHNICAL FEATURES

Struttura / Structure	ABS / ABS
Dimensioni Dimensions	51 x 17,5 x 10,5 h cm 20.08 x 6.89 x 4.13 h in
Peso / Weight	3,0 Kg / 6.6 lb
Vano portarotolo Roll-holder compartment	Con lama taglia sacchetti bi-direzionale integrata anti-infortunio With built-in two-way safety bag cutter
Accessori / Accessories	Tubo canister e cutter alloggiati all'interno del Coperchio / Canister tube and cutter housed inside the lid
Aspirazione Vacuum packaging	Ciclo Automatico con avvio da tastiera Automatic cycle with control panel start
Sistema di suzione con vaschetta ferma liquidi Vacuum chamber with liquid-proof tray	Massimo grado di igiene con il lavaggio anche in lavastoviglie della vaschetta asportabile Maximum hygiene and perfect cleaning with the fully removable bottom dishwasher safe
Preso aria per sottovuoto nei contenitori / Hose port for vacuum packing in containers	Sì / Yes
Barra saldante / Sealing bar	Di tipo professionale in alluminio / Professional aluminum heat sealing bar
Sfiato camera del vuoto / Lid release	Automatico all'apertura / Automatic when opening
Pompa Pompa	Pompa con pistone autolubrificante in teflon a 2 velocità Pump with self-lubricating piston with 2 speeds
Valore vuoto pompa (approx) Pump vacuum value (approx)	60 cm/Hg -0,80 bar -11.6 PSI
Lt / min' (approx)	10
Protezione termica di sicurezza autoripristinante Self-resetting safety thermal protection	Sì Yes
Tensione / Voltage	230V ~ 50Hz
Potenza assorbita / Current drawn	Max 140 W
Stand by / Current drawn in stand by	0 W

Omologazioni / Approvals >



8 018294 014230

MASTER

Codice / Code	V252PK1
Modello / Mode	P0116ED
Imballo / Master carton	n° 3 Pz / 3 pieces
Garanzia / Warranty	3 ANNI / Please refer to your local dealer

MASTER

**MACCHINA
PER IL SOTTOVUOTO**
Vacuum packaging machine

Tecnologia brevettata
Patented technology

I cibi durano
fino a 5 volte di più*

x5

Food fresh up to
5 times longer*



Prestazioni industriali certificate
Certified commercial performances

MAGICVAC

IL VERO SOTTOVUOTO

The original vacuum sealing system



MASTER

NEW

Funzione vuoto manuale a pulsazioni per cibi fragili e delicati
Pulse function for manual vacuum control to preserve fragile and delicate food

- **Semplice e automatica**
Simple and automatic
- **Facilità d'uso con Lock and Unlock System**
Easy to use Lock & Unlock System
- **Pratico oblò per verificare la corretta posizione del sacchetto**
Convenient viewing window for correct bag position
- **Utile vuotometro analogico per controllare il valore del vuoto raggiunto / Useful analog vacuum gauge to check the vacuum value reached**
- **Conforme alla Direttiva ErP consumi di energia**
In compliance with Energy-saving Directive ErP



IN COMPLIANCE WITH BOTH THE 1ST/2ND
STAGE REQUIREMENTS OF THE EC REGULATION
1275/2008 ErP DIRECTIVE 2009/125 EC

Made in Italy

MAGICVAC IL VERO SOTTOVUOTO



FLAEM NUOVA S.p.A.
Via Colli Storici, 221-223-225
25015 S. MARTINO DELLA BATTAGLIA
(Brescia) - ITALY
Phone (39)0309910168 - Fax (39)0309910287
E-mail: info@flaemnuova.it

FLAEM NUOVA S.p.A. è un'azienda
con sistema di qualità certificato.
Company with certified quality system.

www.magicvac.it

MASTER

MACCHINA
PER IL SOTTOVUOTO
Vacuum packaging
machine



5 Vaschetta ferma liquidi estraibile, lavabile in lavastoviglie / Liquid-proof tray, completely removable and dishwasher-safe

NEW

Tastiera impermeabile multifunzione Waterproof multifunction panel

- **Ciclo automatico vuoto+saldatura sacchetti**
Bag vacuum cycle with automatic sealing
- **Ciclo vuoto manuale a pulsazioni / Pulse function**
for manual vacuum control
- **Ciclo automatico vuoto canister / Canister vacuum cycle**
- **Saldatura manuale**
Manual sealing function
- **Regolazione del tempo di saldatura / Presetting of Sealing time**
- **Vuotometro Analogico per controllare il valore del vuoto raggiunto / Analog Vacuum Gauge** To check the vacuum value reached

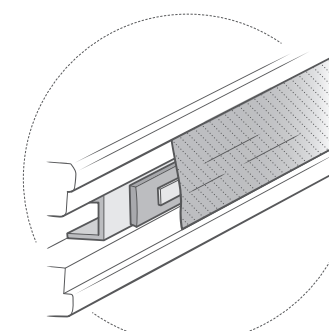

3 Barra saldante professionale in alluminio
Professional aluminium sealing bar



4 Vano portarotolo con taglia-sacchetti bidirezionale integrato / Roll-holder compartment with built-in bag cutter



6 Tubo canister e cutter alloggiati all'interno del Coperchio / Canister tube and cutter housed inside the lid

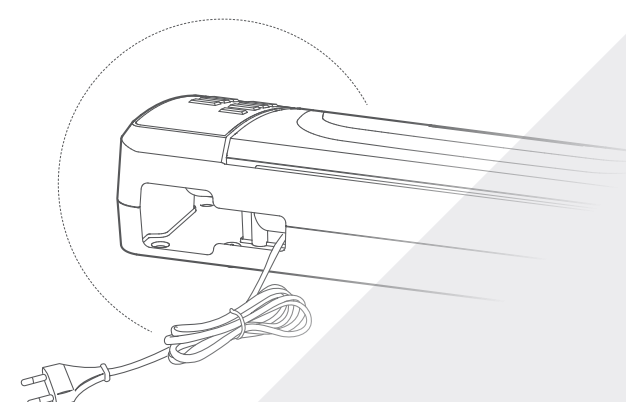

Vano raccogli cavo integrato
Integrated cable compartment



MAGICVAC
IL VERO SOTTOVUOTO

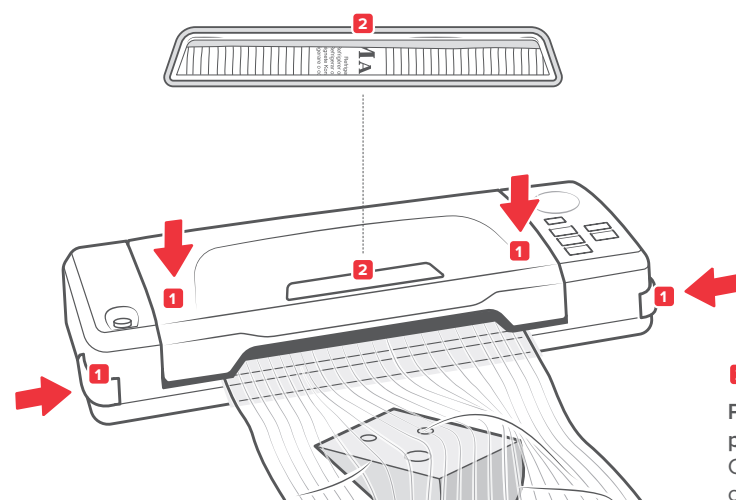

1 Facilità d'uso con Lock & Unlock System
Easy to use Lock & Unlock System

2 Pratico oblò per un corretto posizionamento del sacchetto
Convenient look-in window, for correct plastic bag placement

MAGICVAC
IL VERO SOTTOVUOTO