

V-TAC

Meaningful Innovation.

WEEE Number: 80133970

INSTRUCTION MANUAL LED WATERPROOF FITTING

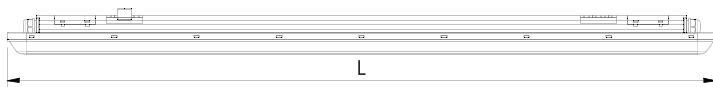

IP65 **02** **YEAR**
RATING **WARRANTY***

TECHNICAL DATA

MODEL	SKU	WATTS	LUMENS	CRI	DF	BEAM ANGLE	LIFE SPAN [Hours]	ON/OFF CYCLE	INPUT POWER	MATERIAL	DIMENSION	MAX CONNECTABLE UNITS
VT-1253S	10213 10215	36W	4320 Lm	≥80	≥0.9	120°	20,000	>15,000	AC:220-240V 50/60 Hz	PC+ABS	1200x64x60mm	10 pcs

SENSOR TECHNICAL DATA

DETECTION RANGE	HF SYSTEM	DETECTION DISTANCE	TIME DELAY	INSTALLATION HEIGHT	DETECTION MOTION SPEED	WORKING TEMPERATURE
180°	5.8GHz CW radar ISM Band	Side Sensing Distance: 3-4m Front Sensing Distance: 5-8m	100% for 60 seconds 20% for 120 seconds	2-4m	0.6-1.5m/s	-20°C to +40°C

INTRODUCTION & WARRANTY

Thank you for selecting and buying V-TAC product. V-TAC will serve you the best. Please read these instructions carefully before starting the installation and keep this manual handy for future reference. If you have any other query, please contact our dealer or local vendor from whom you have purchased the product. They are trained and ready to serve you at the best. The warranty is valid for 2 years from the date of purchase. The warranty does not apply to damage caused by incorrect installation or abnormal wear and tear. The company gives no warranty against damage to any surface due to incorrect removal and installation of the product. The products are suitable for 10-12 Hours Daily operation. Usage of product for 24 Hours a day would void the warranty. This product is warranted for manufacturing defects only.

WARNING

1. Please make sure to turn off the power before starting the installation.
2. Installation must be performed by a qualified electrician.
3. The light source of this luminaire is not replaceable, when the light source reaches its end of life the whole luminaire should be replaced.
4. If the external flexible cable or cord of this luminaire is damaged, it shall be exclusively replaced by the manufacturer or his service agent or a similar qualified person in order to avoid a hazard.

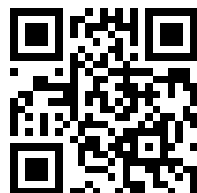

MULTI-LANGUAGE MANUAL QR CODE

Please scan the QR code to access the manual in multiple languages.

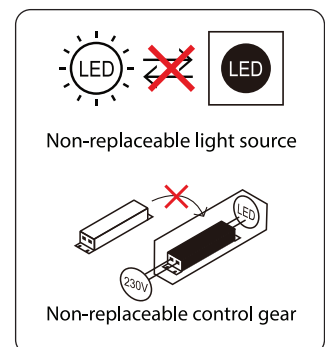

In case of any query/issue with the product, please reach out to us at: support@v-tac.eu
For More products range, inquiry please contact our distributor or nearest dealers.
V-TAC EUROPE LTD. Bulgaria, Plovdiv 4000, bul.L.Karavelov 9B



This marking indicates that this product should not be disposed of with other household wastes.



Caution, risk of electric shock.

INSTALLATION INSTRUCTION

1. Take the 2 pcs stainless steel brackets out from accessories bag, fix them onto the ceiling by offered screws and expansion tubes.

MODEL	L1
VT-1253S	790±30mm

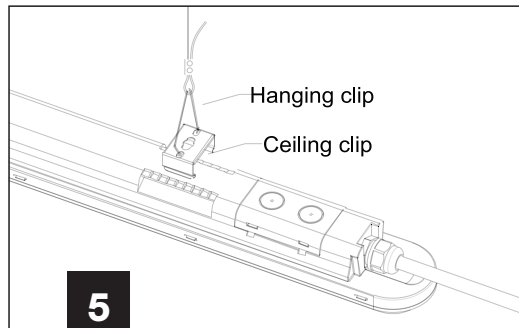
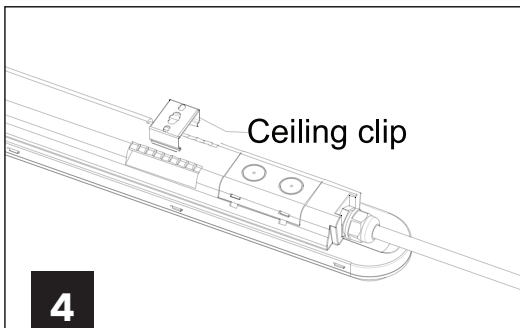
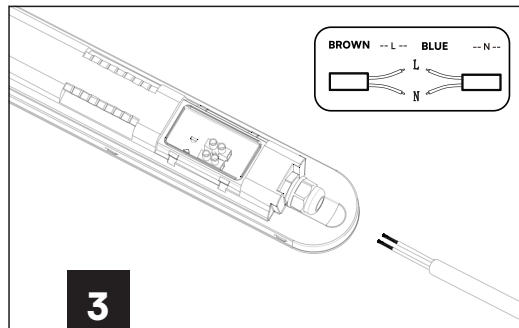
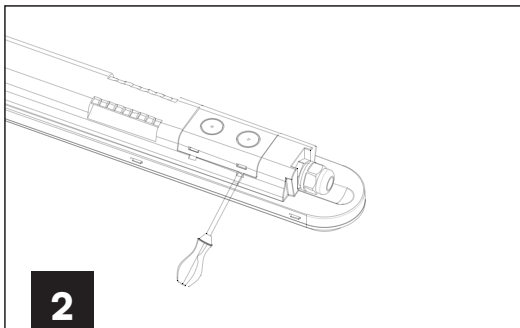
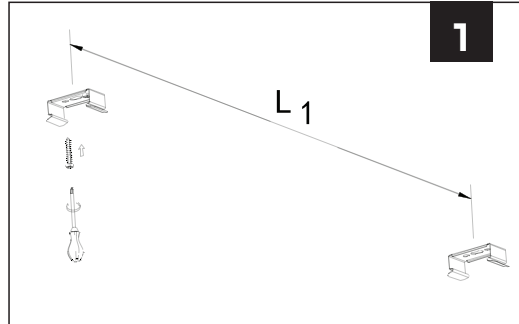

2. Open junction box cover of the body with screwdriver.
3. Fasten the waterproof connector clockwise. Insert cable through the waterproof connector and wire it into terminal block. Make sure L and N are wired to correct holes. (LIVE = BROWN; NEUTRAL = BLUE).
4. Cover back to junction box cover, install the lamp to the ceiling clips.
5. Hanging installation type reference. (Suspension clips need to be purchased separately)

RoHS



UK
CA



Not Dimmable



PAP