

DOC.NO:

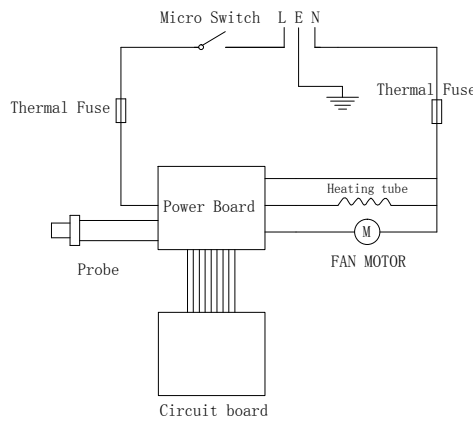
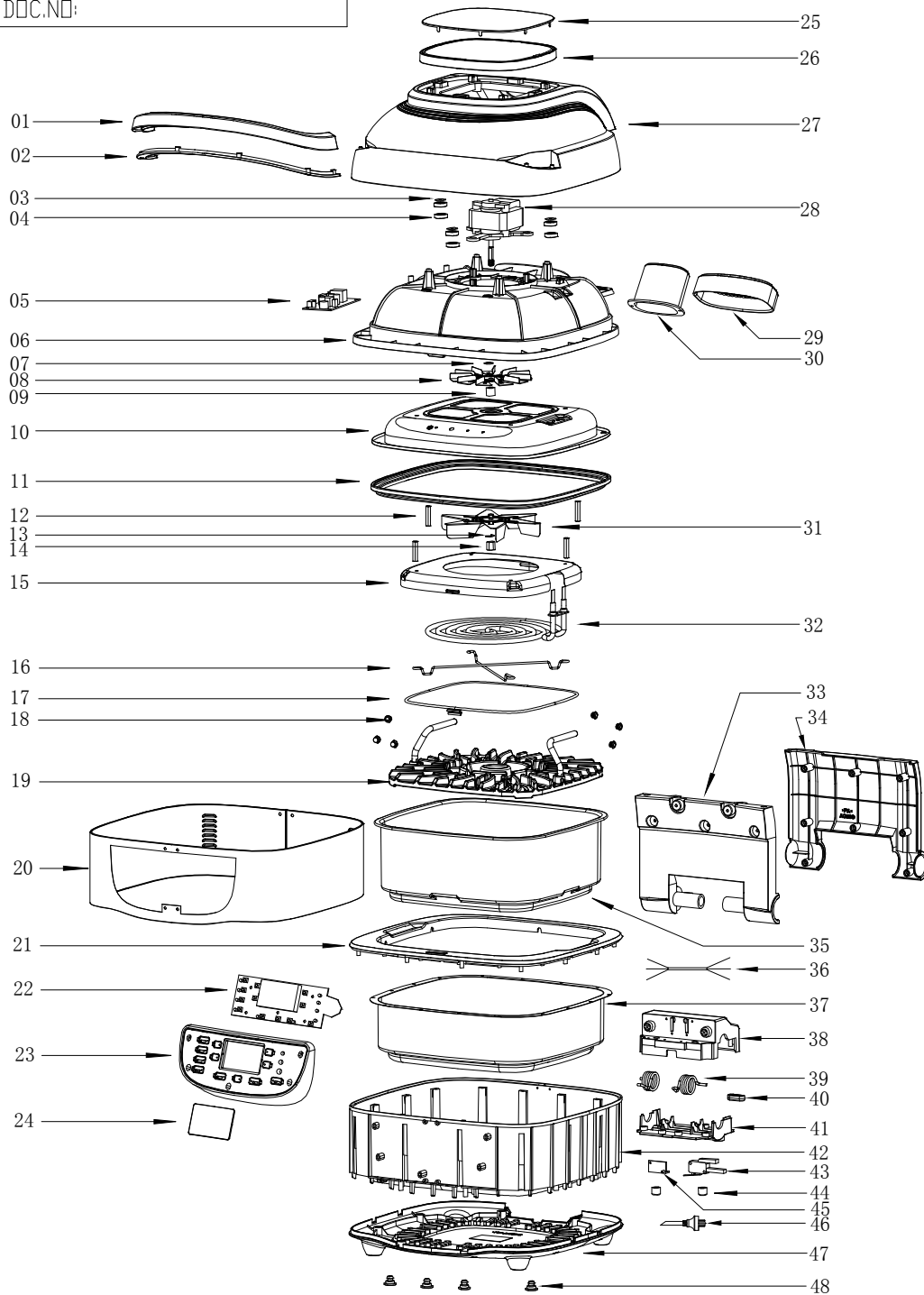

48	Mats	脚垫	4	Silica gel	
47	Base	底座	1	PP	
46	Power cord	电源线	1		
45	Switch stents	开关固定块	1	PA	
44	Mats	脚垫	2	Silica gel	
43	Micro switch	微动开关	1		
42	Liner	内胆	1	PA	
41	Bottom cover	底盖	1	PA	
40	Cord holder	压线码	1	PA	
39	Spring	弹簧	2		
38	Rocker arm bracket	摇臂支架	1	PA	
37	Pot support	锅支架	1	T=0.5	
36	Internal wiring	内配线	1		
35	Aluminum pot	铝锅	1		
34	Rocker cover	摇臂盖	1	PA	
33	Rocker arm	摇臂	1	PA	
32	Heating tube	发热管	1		
31	Hot air blade	热风叶	1	T=0.5	
30	Wind deflector	导风罩	1		
29	Wind hood	出风罩	1	PA	
28	FAN MOTOR	电机	1		
27	Up Body	上壳	1	PP	
26	Upper cover	上盖	1	ABS	
25	Upper cover SUS	不锈钢盖	1	SUS	
24	Display panel	显示板	1	PC	
23	Control panel bracket	控制板支架	1	ABS	
22	Control panel	控制板	1		
21	Pressure ring	压环	1	PA	
20	Baffle	围板	1	SUS	
19	Baking tray	烤盘	1		
18	Pot support foot	锅支撑脚	6	Silica gel	
17	Net cover	网罩	1	SUS	
16	Fixing rod	固定杆	2	SUS	
15	Heating pipe bracket	发热管支架	1	T=0.5	
14	Nut	螺母	1	M6, SUS	
13	Spring washer	弹垫	1	φ6×φ9×1.5	
12	Bracket	支架	4		
11	Seal ring	密封圈	1	Silica gel	
10	Heat shield	隔热罩	1	T=0.5	
09	Blade fixing sleeve	风叶固定套	1	φ6×φ12×11	
08	Cold blade	冷风叶	1	T=0.5	
07	Flat gasket	平垫片	1	φ6×φ12.5×1.2	
06	Motor bracket	电机支架	1	PA	
05	Power Board	电源板	1		
04	Motor mat	电机脚垫	6		
03	Shim	垫片	3	φ3.5×φ15×1.0	
02	Handle cover	手柄盖	1	ABS	
01	Handle	把手	1	ABS	
ITEM	ENGLISH NAME	NAME	QTY	MAT'L&SPEC	REMARK

Ningbo Manhua Electric Appliances CO., Ltd.

MODEL: A0688 DWGNO: A0688-00-01

TITLE: 爆炸图 Exploded Drawing REV: A

	SCALE:	PREPARED BY:	DATE:
	SHEET: 1 OF 1	CHECKED BY:	DATE:
	UNITS: mm	REVIEWED BY:	DATE:
	FRAME: A3	APPROVED BY:	DATE: