

BUILD THE

# NISSAN GT-R

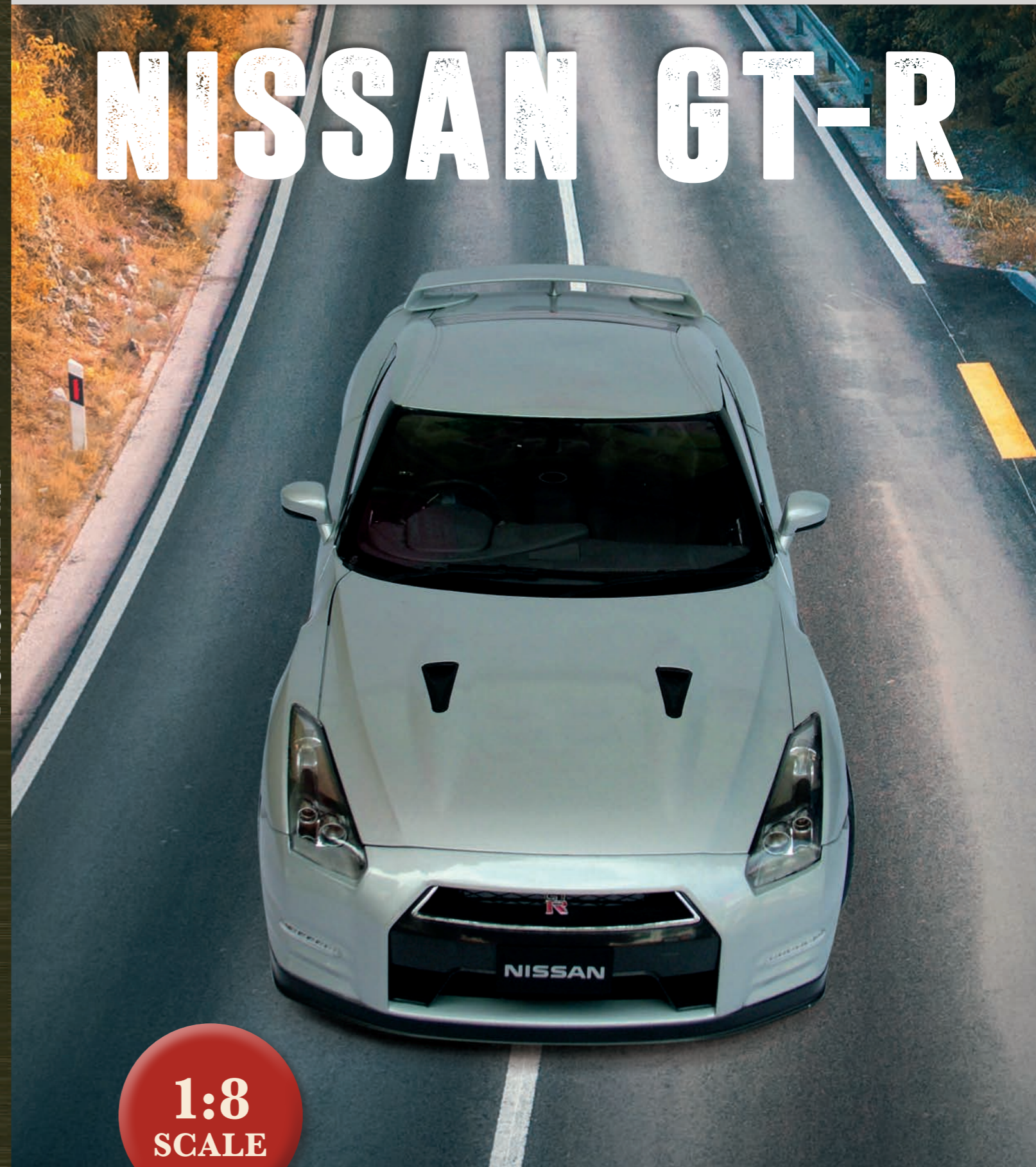

BUILD THE NISSAN GT-R



1:8  
SCALE



# HOW TO BUILD

## FRONT FASCIA ASSEMBLY

In this issue, you will assemble the Front Fascia of the NISSAN GT-R, including the distinctive Front Grille and Chin Spoiler. The parts fit easily together and these instructions take you through the construction in a few simple steps.

**PARTS LOCATION**



**TIP!**  
The only tools needed to build your NISSAN GT-R model are a set of Phillips screwdrivers and a wrench.

### PARTS LIST

### PART IDENTIFICATION LIST

PART No.	NAME	QUANTITY	MATERIAL
01A	Grille Support	1	ABS
01B	Inner Fascia	1	Zinc
01C	Front Fascia	1	Zinc
01D	Upper Grille	1	Photo etched
01E	Lower Grille	1	Photo etched
01F	GT-R Emblem	1	ABS
Screws	Type AM 0.1 x 0.16" [2.6 x 4 mm]	6 [+2 spares]	Metal
Screws	Type BM 0.06 x 0.12" [1.5 x 3 mm]	11 [+6 spares]	Metal
Screws	Type BP 0.06 x 0.12" [1.5 x 3 mm]	5 [+1 spare]	Metal

Screws under 0.07" [1.7mm] should be assembled with a small 0.06" [2mm] Phillips-head screwdriver, while screws 0.06" [1.5mm] or larger should be assembled with a 0.12" [3mm] Phillips-head screwdriver.

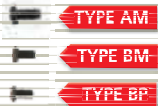

ANY SCREWS NOT BEING USED SHOULD BE KEPT IN A SAFE PLACE FOR LATER.



**TIP!**  
Make sure that you don't mix up the Type BM screws with the Type BP screws. They look very similar but are different. The threads on the BP screws are wider than they are on the BM screws. Using the wrong screws may damage the parts.



## STEP 01

### Join the Grille Support to the Inner Fascia

Line up the 4 holes on the bottom of the Grille Support [01A] with the 4 holes on the back of the Inner Fascia [01B] and join them using 4 **TYPE AM** screws.

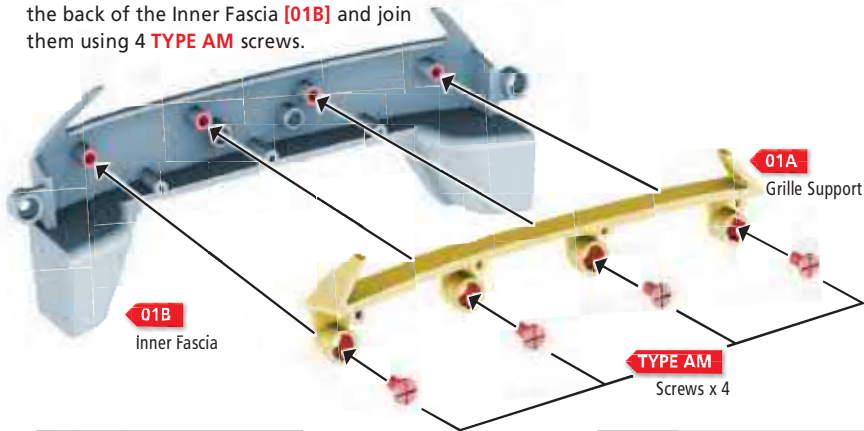

#### COLOR KEY

- PART BEING FITTED
- PART BEING FITTED TO
- FIXINGS

#### STEP 01 COMPLETE

#### TIP!

Be careful not to screw the parts too tightly, as this could damage them.

## STEP 02

### Join the Inner Fascia to the Front Fascia

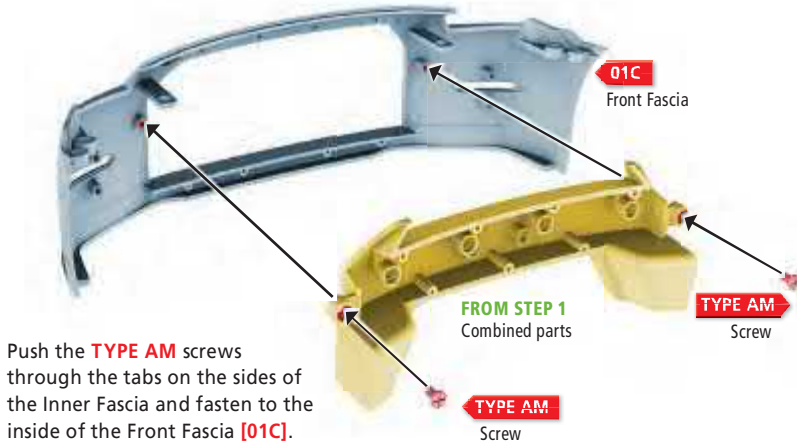

Push the **TYPE AM** screws through the tabs on the sides of the Inner Fascia and fasten to the inside of the Front Fascia [01C].

#### STEP 02 COMPLETE

## STEP 03

### Combine the Upper Grille and the GT-R Emblem

Push the peg on the rear of the GT-R Emblem [01F] through the hole in the center of the Upper Grille [01D] and then use a **TYPE BP** screw to hold it in place.

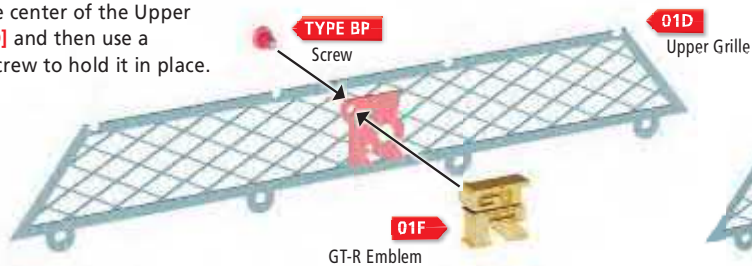

#### STEP 03 COMPLETE

# HOW TO BUILD

## STEP 04 Add the Upper Grille to the Front Fascia Assembly

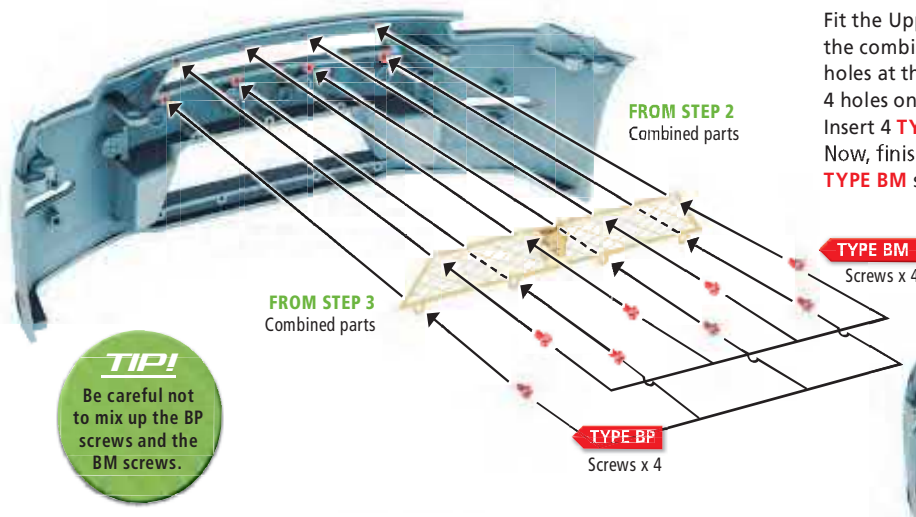

Fit the Upper Grille (with the GT-R Emblem on it) to the combined Front Fascia Assembly. Line up the 4 holes at the bottom of the Upper Grille [01D] with the 4 holes on the inside of the Front Fascia Assembly. Insert 4 **TYPE BP** screws through the bottom 4 holes. Now, finish securing the Upper Grille by inserting 4 **TYPE BM** screws into the remaining top 4 holes.



## STEP 05 Add the Lower Grille

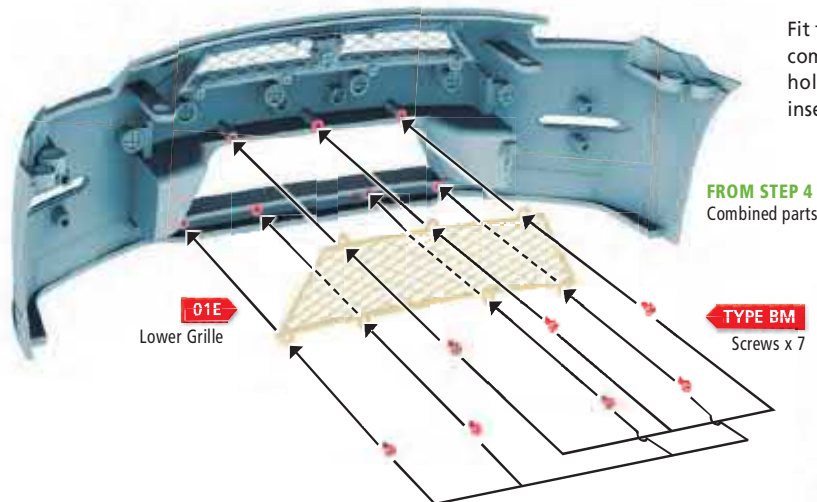

Fit the Lower Grille [01E] to cover the lower gap in the combined Front Fascia Assembly. After lining up the holes, secure the Lower Grille with 7 **TYPE BM** screws inserted into the holes on both top and bottom.



## Complete!

This stage is now finished

Further parts will be added to the Front Fascia Assembly later, including the Front License Plate and Turn Signals. Keep any screws you haven't used in a safe place, as they will connect the Front Fascia Assembly to the rest of the car later.



**TIP!**  
Be careful to keep completed parts out of reach of small children.

# WHEEL ASSEMBLY

Now it is time to fit the Rear Right Tire to the Rear Right Wheel of your NISSAN GT-R model.

**PARTS  
LOCATION**



## PARTS LIST

### PART IDENTIFICATION LIST

PART No.	NAME	QUANTITY	MATERIAL
02A	Wheel	1	Zinc
02B	Tire	1	PVC
02C	Wheel Cap	1	ABS
Screws	Type CM 0.1 x 0.2" [2.6x 6mm]	2 [+1 spare]	Metal



### TIP!

The Wheel Cap and screw will not be fitted until later, so keep them safe.

# HOW TO BUILD

## STEP 01

Place the Tire in a container of warm water

The Tire [02B] needs to fit tightly on to the Wheel and it can be difficult to push it on. To make it easier, place the Tire in a container of warm water and leave it to soak for approximately 5 minutes.



### COLOR KEY

- PART BEING FITTED
- PART BEING FITTED TO
- FIXINGS

## STEP 02

Fit the Tire to the Wheel

Now take the Tire [02B] out of the water – it should be softer and easier to manipulate – and ease it slowly over the Wheel [02A]. Make sure the rough side of the tread pattern (see illustration) faces the outside of the Wheel.

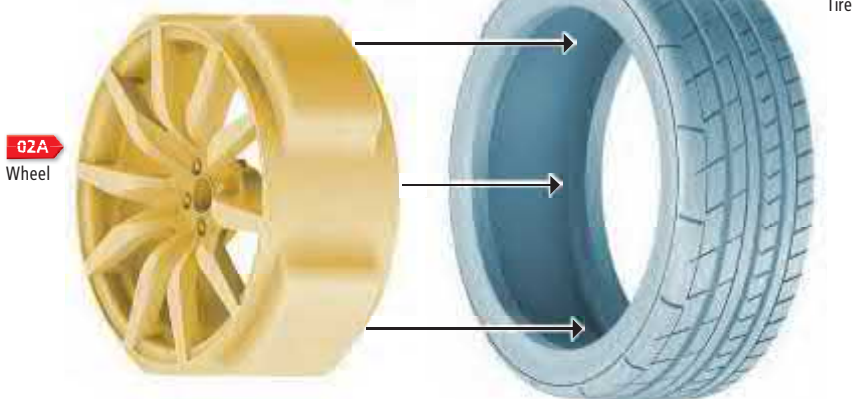

## STEP 05 COMPLETE



## Complete!

Rear Right Wheel is completed

This combined Wheel and Tire will be joined to Suspension Parts that come with the next volume, when you will also fit the Wheel Cap [02C]. Keep it in a safe place for now.



### TIP!

The model tire has the same Dunlop tread pattern as the real car.





## REAR BRAKE DISC ASSEMBLY

In this magazine, you will fit together the parts that make up the Rear Right Brake Disc for your NISSAN GT-R (R35).

### PARTS LOCATION



### PARTS LIST



03A



03B



03C

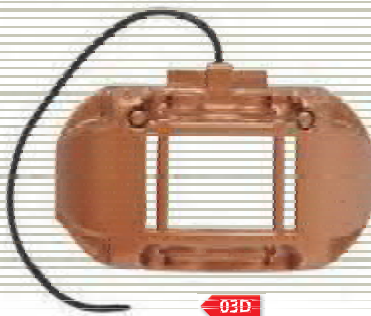

03D

### PART IDENTIFICATION LIST

PART No.	NAME	QUANTITY	MATERIAL
03A	Brake Disc Plate	1	photo etch
03B	Brake Disc Base	1	ABS
03C	Brake Disc Plate Hub	1	ABS
03D	Brake Caliper with Brake Cable attached	1	Zinc
Screws	Type BM 0.05 x 0.1" [1.5 x 3mm]	2 [+1 spare]	Metal
Screws	Type BP 0.05 x 0.1" [1.5 x 3mm]	2 [+1 spare]	Metal

### TIP!

The Brake Caliper (03D) will not be required until later, so keep it safe.



TYPE BP



TYPE BM

ALSO WITH THIS MAGAZINE:  
0.06" [2mm] PHILLIPS-HEAD SCREWDRIVER



(Design of the screwdriver may vary.)

## STEP 01

### Apply the Brake Disc Plate to the Brake Disc Base

#### COLOR KEY

- PART BEING FITTED
- PART BEING FITTED TO
- FIXINGS

Hold the Brake Disc Base [03B] with the vanes facing up (see illustration) and place the Brake Disc Plate [03A] onto it, turning it until the screw holes line up. Do not screw the parts together yet.

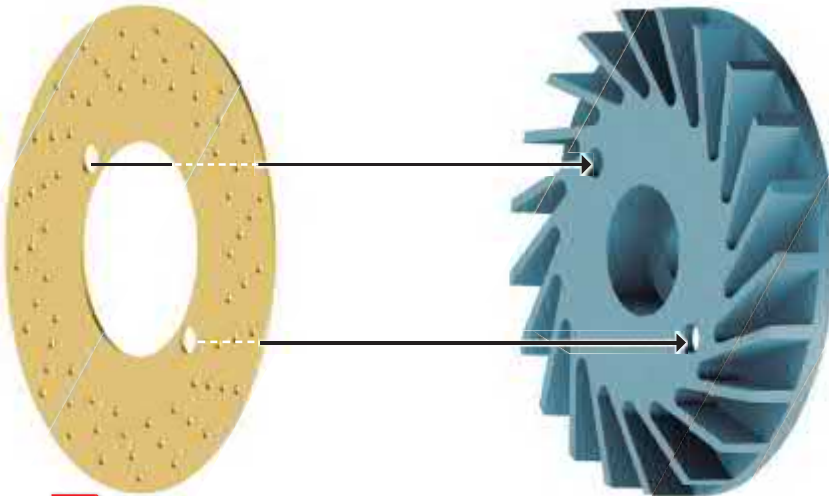

03A

Brake Disc Plate

03B

Brake Disc Base



## STEP 02

### Add the Brake Disc Plate Hub

Take the Brake Disc Plate Hub [03C] and push its pegs through the holes on the Brake Disc Plate, holding it all together with your fingers.

Brake Disc Plate Hub

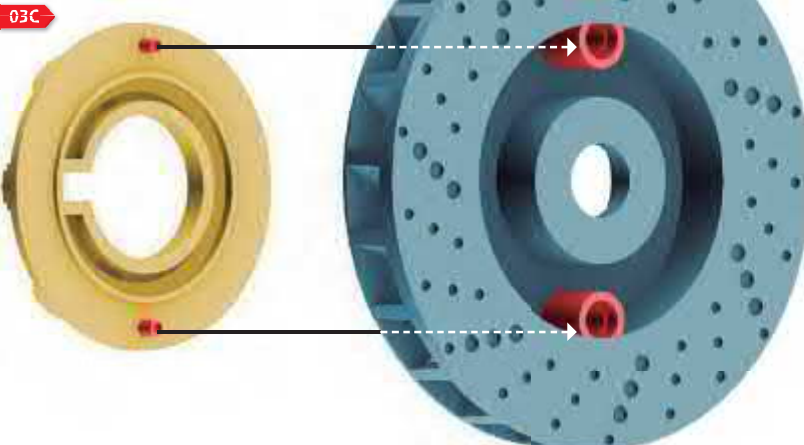

03C

FROM STEP 1  
Combined parts



# HOW TO BUILD

## STEP 03 Fix the Brake Disc parts together

From the opposite side of the Brake Disc Hub, use two **TYPE BP** screws to hold the parts together.

**TYPE BP**  
Screw

**TYPE BP**  
Screw

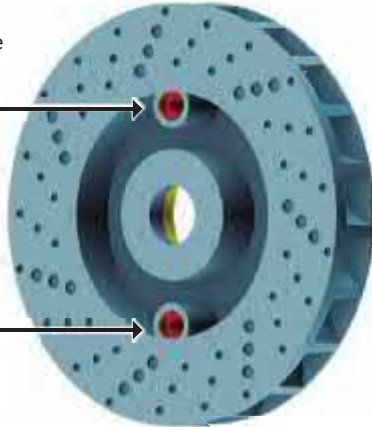

STEP 03 COMPLETE

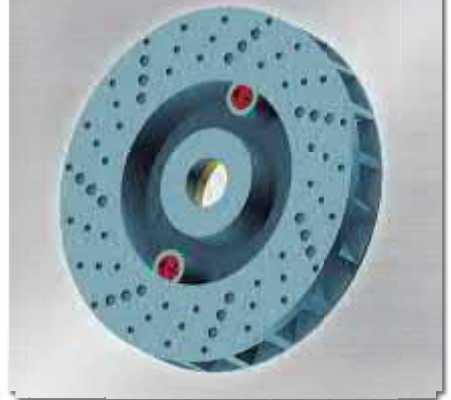

## Complete!

### Completion of Rear Brake Disc

The Rear Right Brake Disc is now assembled and will be fitted to the parts that come with the Brake Caliper.



### TIP!

Be careful to keep completed parts out of reach of small children.

## NISSAN GT-R BRAKE DISCS

Your model has a gold-colored caliper, branded with a large black NISSAN logo over a smaller red Brembo logo, just like the real NISSAN GT-R.

The NISSAN GT-R is capable of astonishing acceleration, so it requires powerful brakes to match and help rein in its 530 hp engine. The brake discs were developed in association with Brembo, the specialist Italian company that supplies brake systems to several Formula One teams.

The NISSAN GT-R has brake discs on all four wheels and they can bring the car to

a complete halt from 62 mph (100 km/h) in less than 98 ft (30 m).

### HEAT-RESISTANT

Unlike many other performance cars' brakes, which stop working as effectively because they become too hot, the NISSAN GT-R's brakes keep on working due to their high heat resistance.

► Close-up of NISSAN GT-R's race car-style brake discs.



# Rear Right Suspension Assembly

Now it is time to assemble the Rear Right Suspension of your NISSAN GT-R (R35) and combine it with the parts you assembled earlier.

## PARTS LOCATION

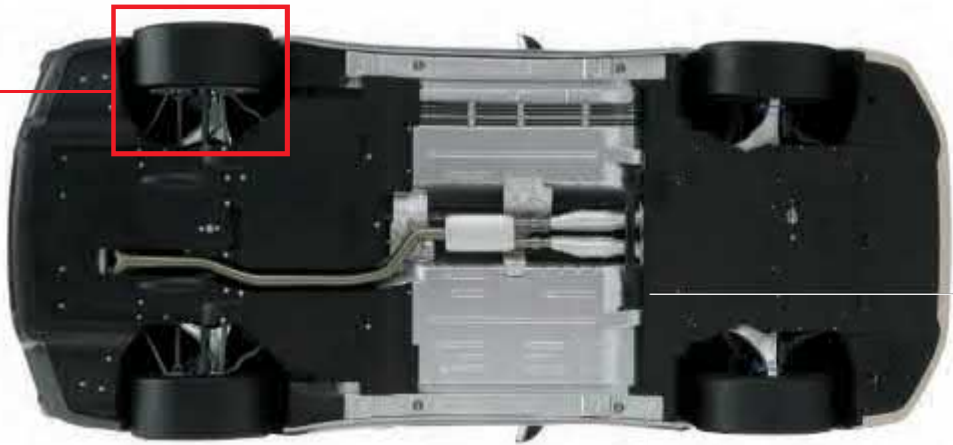

## PARTS LIST



## PART IDENTIFICATION LIST

PART No.	NAME	QUANTITY	MATERIAL
04A	Upper Mount	1	Zinc
04B	Coil Spring	1	Metal hardware
04C	Stroke	1	Zinc
04D	Knuckle Base	1	Zinc
04E	Upper Join	1	Zinc
04F	Lower Toe Strut Bar (long)	1	Zinc
04G	Lower Toe Strut Bar (short)	1	Zinc
04H	Lower Sway Bar	1	Zinc
04I	Anti Roll Bar	1	Metal hardware
Screws	Type DM 0.07 x 0.11" [2 x 3mm]	3 [+2 spares]	Metal + Nuts
Screws	Type EM 0.07 x 0.4" [2 x 10mm]	4 [+3 spares]	Metal + Nuts

ALSO WITH THIS MAGAZINE:  
TOOL FOR TIGHTENING NUTS &  
0.12" [3mm] PHILLIPS-HEAD SCREWDRIVER



(Design of the screwdriver may vary.)

## STEP 01 Combine the Shock Absorber

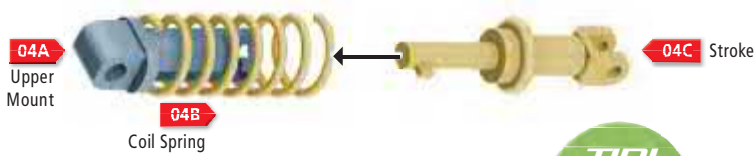

**COLOR KEY**  
 ■ PART BEING FITTED  
 ■ PART BEING FITTED TO  
 ■ FIXINGS

Insert the Upper Mount [04A] inside the Coil Spring [04B] and then slide the Stroke [04C] through the other end of the Coil Spring. Turn the Stroke so that its peg slides up inside the Upper Mount.

**TIP!**  
 Once done, set aside for the moment.



## STEP 02 Add the Upper Join to the Knuckle Base

Slot the Upper Join [04E] onto the Knuckle Base [04D], as shown in the illustration, and then slide a TYPE EM screw from the top through the holes and secure it with the nut.

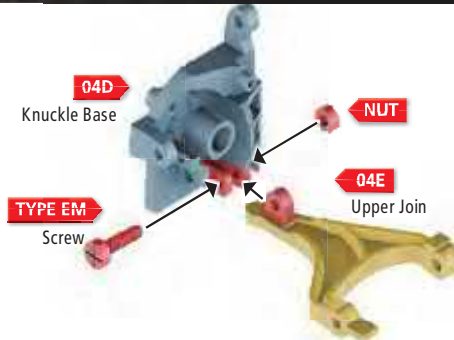

**TIP!**  
 If you have difficulty tightening the nut, use the wrench provided with this magazine.

## STEP 03 Add the combined Upper Mount, Coil Spring and Stroke to the Knuckle Base

Slot the combined Upper Mount, Coil Spring and Stroke that you assembled earlier onto the Knuckle Base, as shown in the illustration, and then slide a TYPE EM screw from the top through the holes and secure them with the nut.

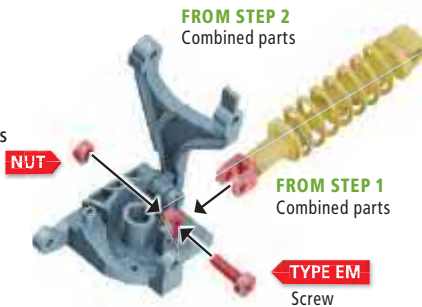

**TIP!**  
 Use the magnetic screwdriver to help position the nut if you have difficulty.

## STEP 04 Add the Lower Toe Strut Bars (long and short) to the Knuckle Base

Slot the Lower Toe Strut Bar (long) [04F] onto the Knuckle Base, as shown in the illustration, and then slide a TYPE EM screw through the holes and secure it with the nut. Now, slot the Lower Toe Strut Bar (short) [04G] onto the Knuckle Base and secure with a TYPE EM screw and nut.

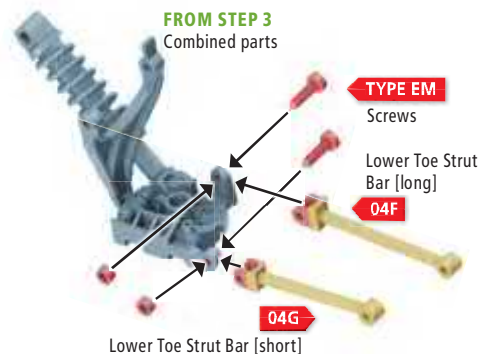

## STEP 05

### Add the Lower Sway Bar to the Knuckle Base

Place the Lower Sway Bar [04H] onto the Knuckle Base, as shown in the illustration, and secure it with a **TYPE DM** screw. Do not try to screw it in too tightly, as the Lower Sway Bar should be slightly loose.

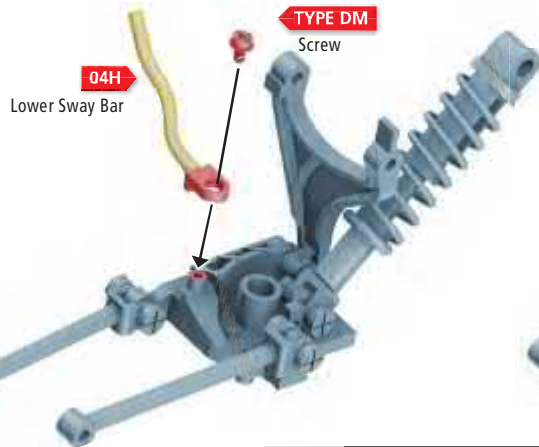

## STEP 06

### Add the Anti Roll Bar to the Knuckle Base

Place the Anti Roll Bar [04I] onto the Knuckle Base, as shown in the illustration, and secure it with a **TYPE DM** screw.

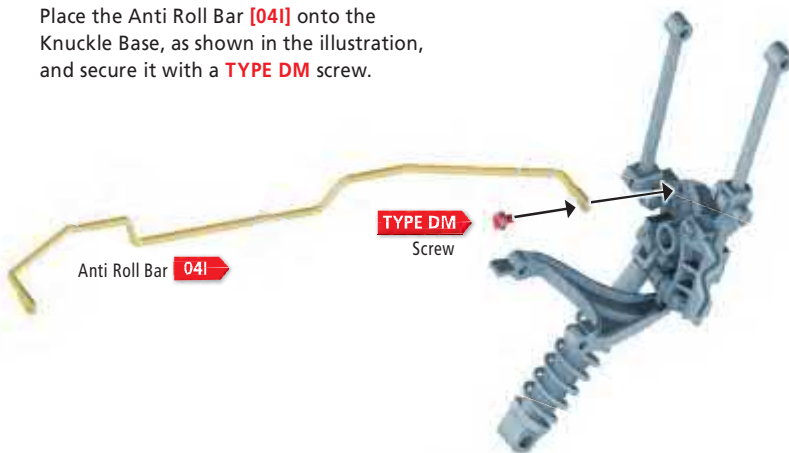

## STEP 07

### Add the Rear Right Brake Caliper to the Knuckle Base

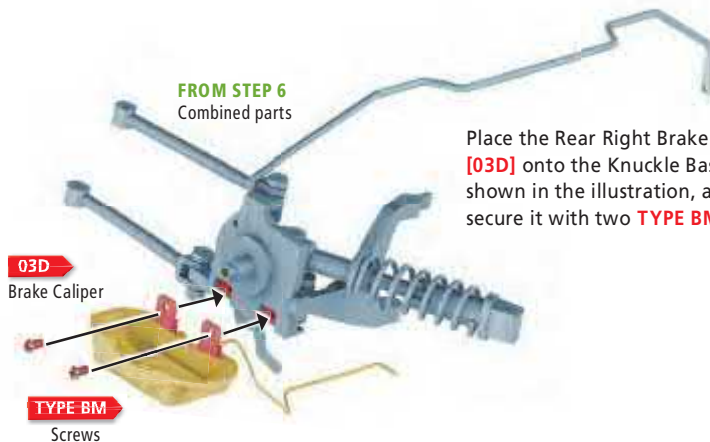

Place the Rear Right Brake Caliper [03D] onto the Knuckle Base, as shown in the illustration, and secure it with two **TYPE BM** screws.



# HOW TO BUILD

## STEP 08 Add the combined Rear Right Brake Disc to the Knuckle Base

FROM STEP 7  
Combined parts

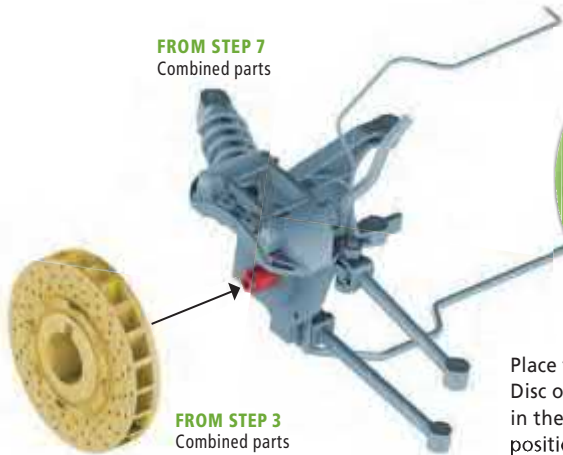

FROM STEP 3  
Combined parts

### TIP!

If your wheel feels wobbly once it has been screwed in, you can use the washers you receive with the next brake disc (pack 19) to make the fit more precise later. If you wish to use these, please do not push the wheel cap in yet. Keep it in a safe place.

Place the combined Rear Right Brake Disc onto the Knuckle Base, as shown in the illustration, and hold it in position with your fingers.

STEP 08 COMPLETE



## STEP 09 Add the combined Wheel and Tire [from Magazine 1] to the Knuckle Base

Add the combined Wheel and Tire from Magazine 1 to the combined Knuckle Base, as shown below, and secure it with a TYPE CM screw that came with Magazine 1. Then, loosely push on the Wheel Cap [02C] that also came with Magazine 1. You will remove this wheel to fit washers at a later stage.



FROM STEP 8  
Combined parts

STEP 09 COMPLETE



## Complete!

You have completed the Rear Right Suspension, Brake System and Wheel

This combined section will later be joined to the Rear Suspension Lower Mount parts.



### TIP!

Keep this completed section somewhere safe for later.

# LIGHTS AND LICENSE PLATE

Now you will fit the LED Daytime Lights, Turn Signals and License Plate to the Front Fascia Assembly that you received with **Magazine 1**.



## PARTS LIST



05A



05B

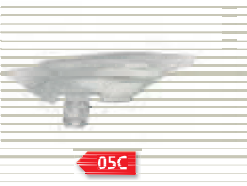

05C

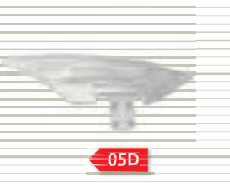

05D



05E

### PART IDENTIFICATION LIST

PART No.	NAME	QUANTITY	MATERIAL
05A	Left LED Daytime Light	1	ABS
05B	Right LED Daytime Light	1	ABS
05C	Left Turn Signal	1	GP
05D	Right Turn Signal	1	GP
05E	License Plate	1	Zinc
Screws	Type AM 0.1 x 0.16" [2.6 x 4mm]	4 [+2 spares]	Metal
Screws	Type BM 0.06 x 0.11" [1.5 x 3mm]	2 [+1 spare]	Metal
Screws	Type BP 0.06 x 0.11" [1.5 x 3mm]	2 [+2 spares]	Metal



TYPE AM



TYPE BM



TYPE BP

ALSO WITH THIS MAGAZINE:  
BUFFING CLOTH



(Design of the buffing cloth may vary.)



## STEP 01 Attach the Left and Right LED Daytime Lights

**COLOR KEY**  
■ PART BEING FITTED  
■ PART BEING FITTED TO  
■ FIXINGS



Take the Front Fascia Assembly that you completed in **Magazine 1** and turn it around so that you are looking at the rear side of it. Slot the Left LED Daytime Light **[05A]** into the hole on the left side and secure it with two **TYPE AM** screws. Now, push the Right LED Daytime Light **[05B]** into the hole on the right of the Front Fascia and secure it with two **TYPE AM** screws.



## STEP 02 Attach the Left and Right Turn Signals to the Front Fascia Assembly



Push the peg on the Left Turn Signal **[05C]** into the hole at the top of the left side of the Front Fascia Assembly and secure it from underneath with a **TYPE BP** screw. Now do the same with the Right Turn Signal **[05D]** on the opposite side.



## STEP 03

### Attach the License Plate to the Front Fascia Assembly

Push the pegs on the back of the License Plate (05E) through the holes on the outward-facing side of the Front Fascia Assembly and secure it with two TYPE BM screws from the other side.

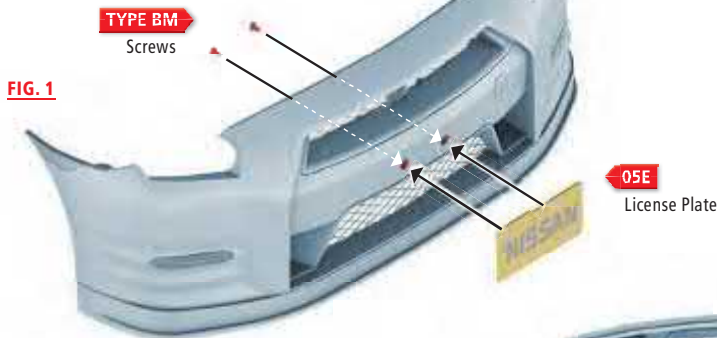

## Complete!

### LED Daytime Lights, Turn Signals and License Plate are attached to the Front Fascia Assembly

We will return to the front of the car later, so keep these combined parts somewhere safe in the meantime.



## MOUNTING THE ENGINE

Now it is time to fit the Engine Covers to the V-type engine Mount and then join the completed part to the Engine Room Bay.

### PARTS LOCATION



### PARTS LIST

#### PART IDENTIFICATION LIST

PART No.	NAME	QUANTITY	MATERIAL
06A	V-type Engine Mount Base	1	Zinc
06B	Right Engine Cover	1	Zinc
06C	Left Engine Cover	1	Zinc
06D	Middle Engine Cover	1	Zinc
06E	Engine Room Bay	1	ABS
Screws	Type GM 0.07 x 0.15" [2 x 4mm]	8 [+ 4 spares]	Metal

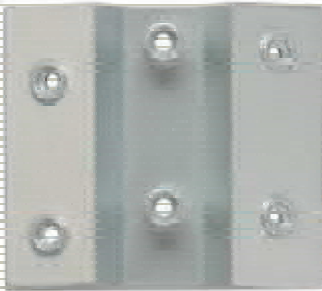

06A



06D

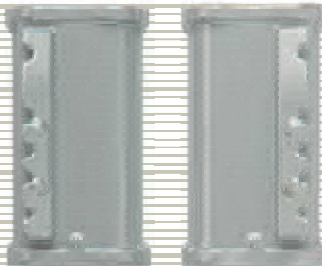

06B

06C

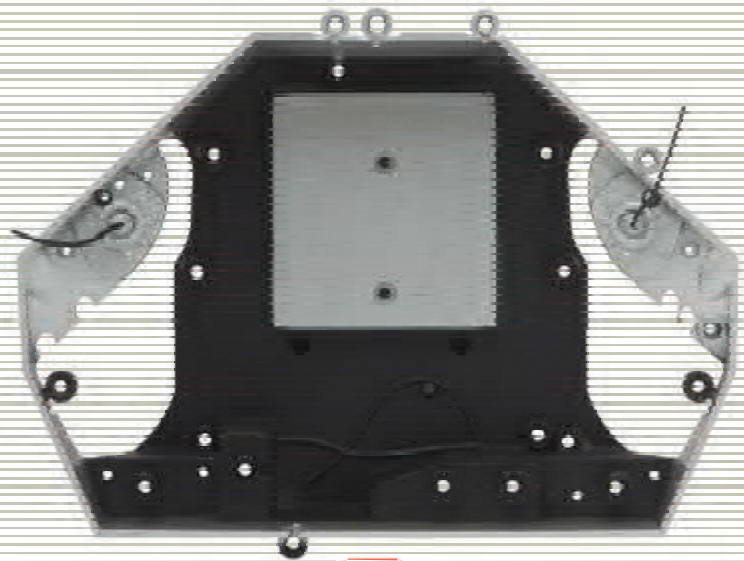

06E

T TYPE GM

## STEP 01

### Attach the Right Engine Cover

Take the Right Engine Cover [06B] and slot the pegs on its underside into the holes on the right side of the V-type Engine Mount Base [06A]. Screw the parts together with two **TYPE GM** screws from the reverse side of the V-type Engine Mount Base.

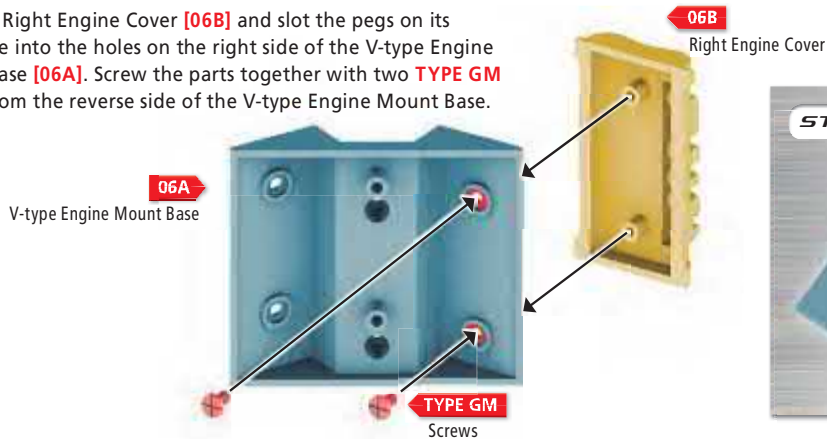

#### COLOR KEY

- PART BEING FITTED
- PART BEING FITTED TO
- FIXINGS

#### STEP 01 COMPLETE



## STEP 02

### Attach the Left Engine Cover

Push the pegs on the back of the Left Engine Cover [06C] into the holes on the left side of the V-type Engine Mount Base [06A] and secure it from underneath with two **TYPE GM** screws.

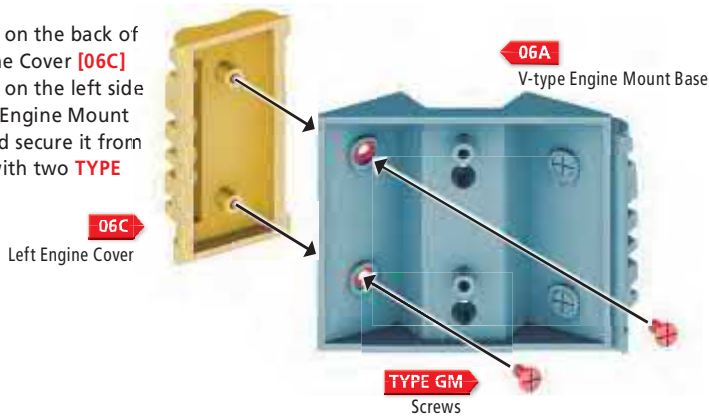

#### STEP 02 COMPLETE



## STEP 03

### Attach the Middle Engine Cover

Fit the pegs on the reverse side of the Middle Engine Cover [06D] into the two holes at the center of the V-type Engine Mount Base [06A] and secure it from underneath with two **TYPE GM** screws.

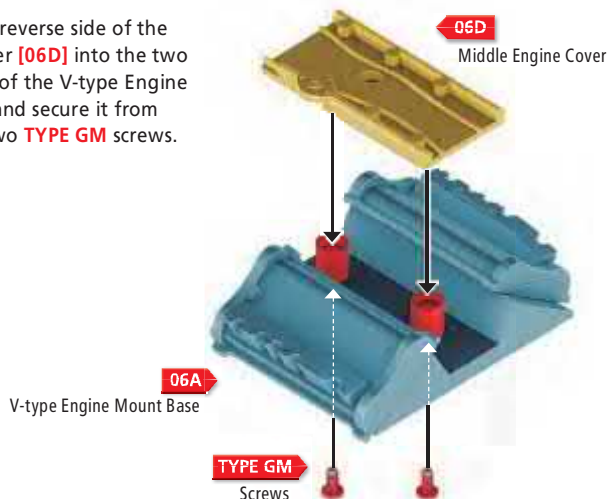

#### STEP 03 COMPLETE



# HOW TO BUILD

## STEP 04 Attach the V-type Engine Mount Base and Covers to the Engine Room Bay

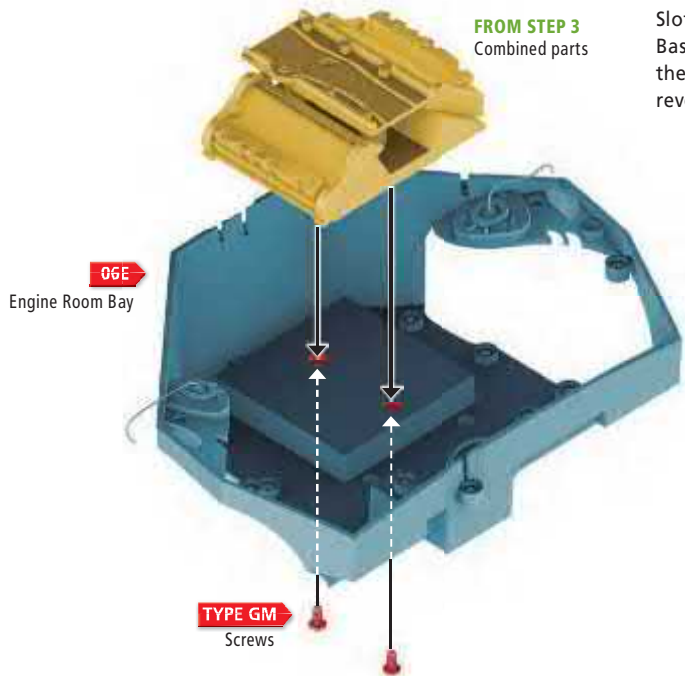

Slot the pegs on the underside of the combined V-type Engine Mount Base and Covers into the two holes on the raised square section inside the Engine Room Bay **[06E]**. Now screw them together from the reverse side of the Engine Room Bay with two **TYPE GM** screws.



## Complete!

You have completed the first part of the Engine Room Bay

You will add more parts to the Engine Room Bay later, so keep these combined parts safe in the meantime.

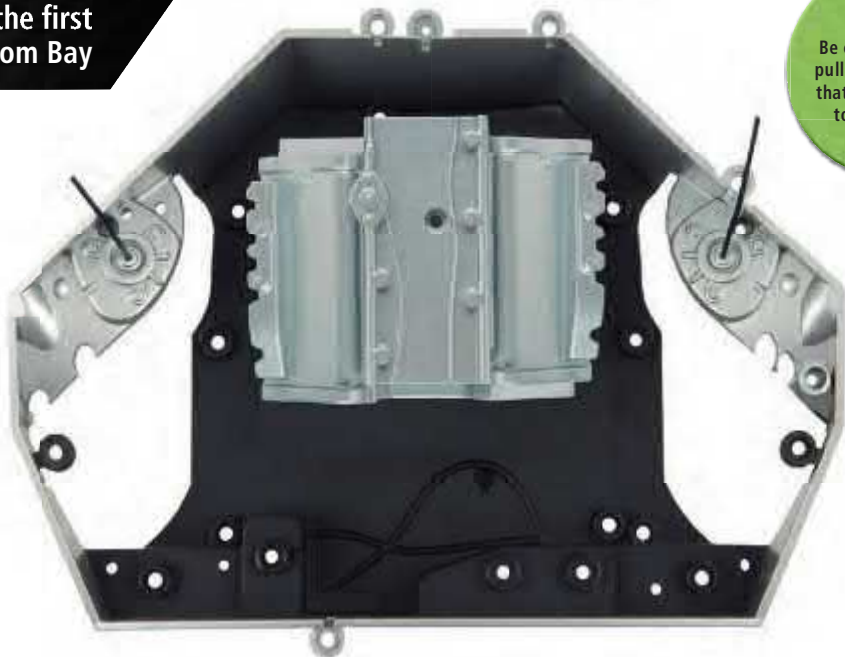

### TIP!

Be careful not to pull off the cables that are attached to the Engine Room Bay.



## REAR GEARBOX AND HALF SHAFTS

In this section, you will fit the Rear Gearbox Base and the Half Shafts to the Rear Gearbox.

### PARTS LOCATION

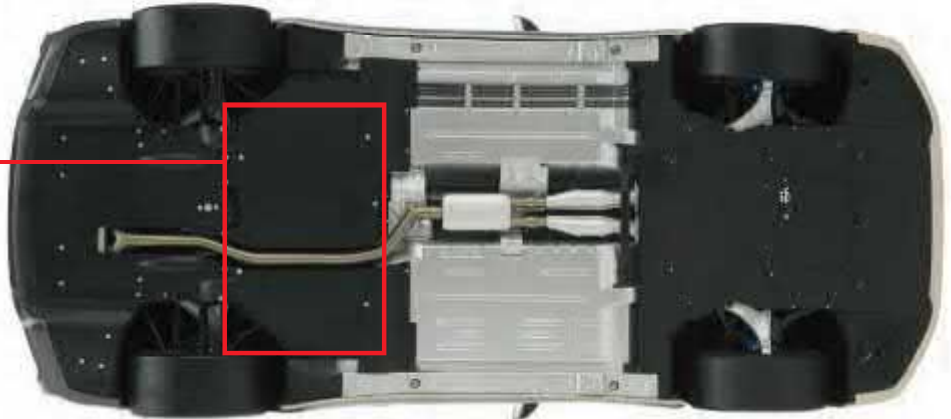

### PARTS LIST

#### PART IDENTIFICATION LIST

PART No.	NAME	QUANTITY	MATERIAL
07A	Rear Gearbox	1	Zinc
07B	Rear Gearbox Base	1	ABS
07C	Left Rear Half Shaft	1	ABS
07D	Right Rear Half Shaft	1	ABS
Screws	Type HP 0.09" x 0.16" [2.3mm x 4mm]	2 (+1 spare)	Metal

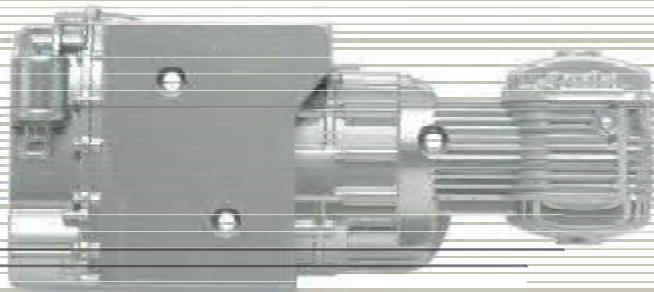

07A

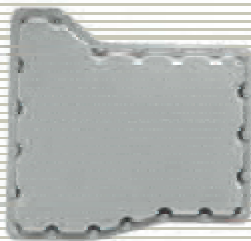

07B

**TIP!**  
The Half Shafts are identical and can be used on either the left or the right.



07C



07D

T

TYPE HP

## STEP 01

### Attach the Rear Gearbox Base

Line up the pegs on the underside of the Rear Gearbox Base [07B] and slot them into the holes on the Rear Gearbox [07A]. Screw the parts together from the reverse side of the Rear Gearbox with two TYPE HP screws.

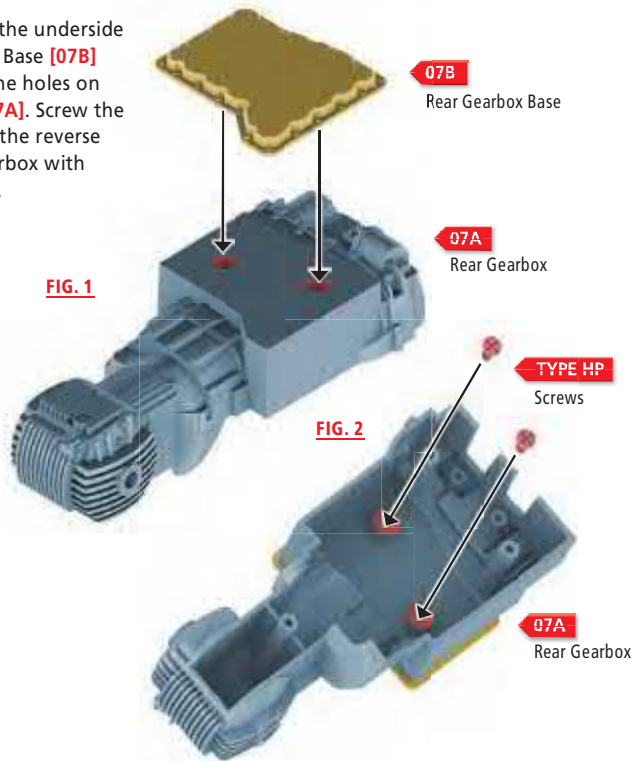

#### COLOR KEY

- PART BEING FITTED
- PART BEING FITTED TO
- FIXINGS



## STEP 02

### Attach the Left Rear Half Shaft

Slot the Left Rear Half Shaft [07C] into the hole on the left side of the Rear Gearbox [07A], as shown in the illustration. This part will be loose and will not hold in place. It will be secured when it is joined by parts in a future magazine.

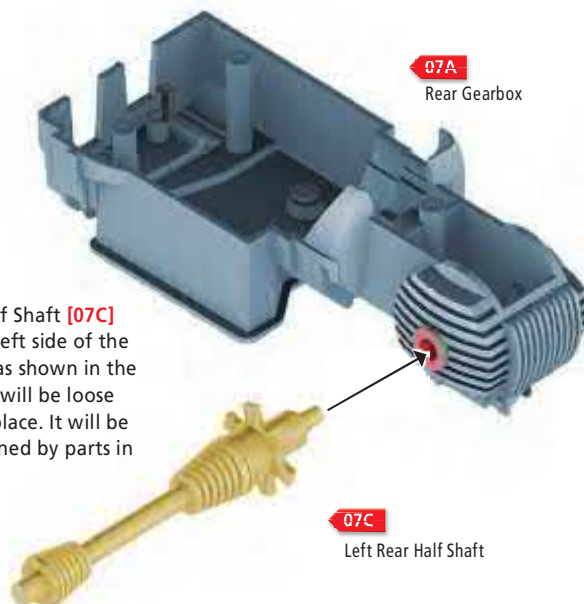



## STEP 03 Attach the Right Rear Half Shaft

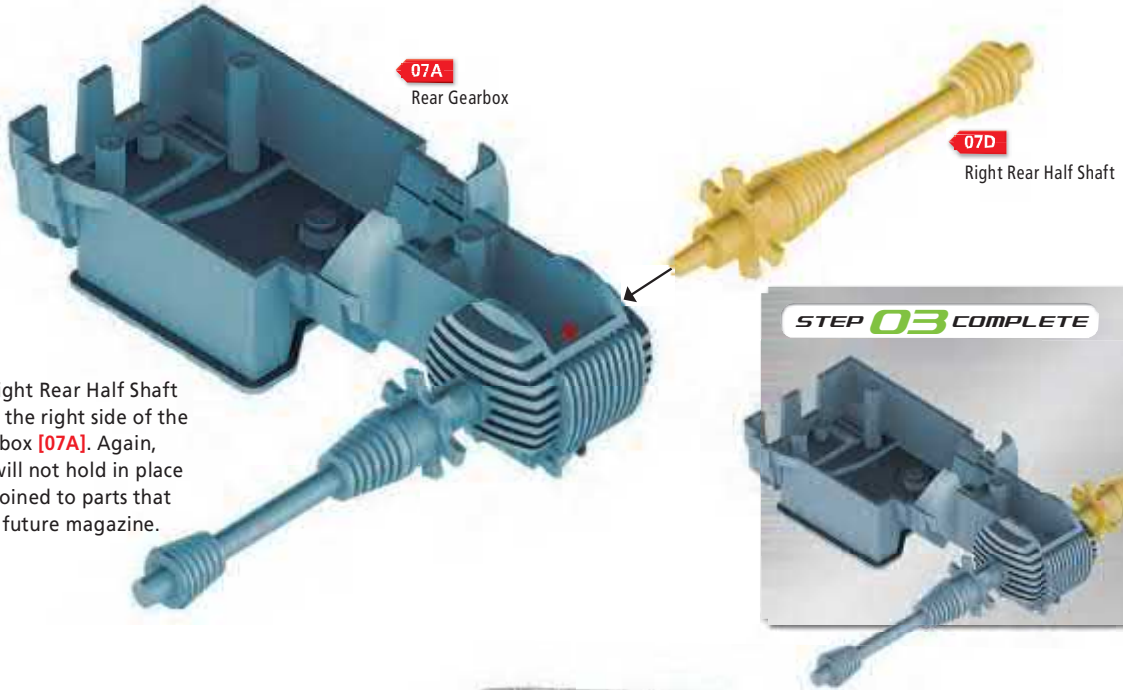

Slot the Right Rear Half Shaft [07D] into the right side of the Rear Gearbox [07A]. Again, this part will not hold in place until it is joined to parts that come in a future magazine.

**Complete!**  
You have finished the first section of the Rear Gearbox

The Rear Gearbox and Half Shafts will be combined with parts that come later, so keep them somewhere safe in the meantime.

**TIP!**

Front and Rear Gear Shafts, plus the Lower Half Shaft, will come later.



# FRONT AND REAR GEARBOX ASSEMBLY

Now you will fit the Front Gearbox Section to the Rear Gearbox and add the Lower Half Shaft and the Lower Gear Shafts.

## PARTS LOCATION

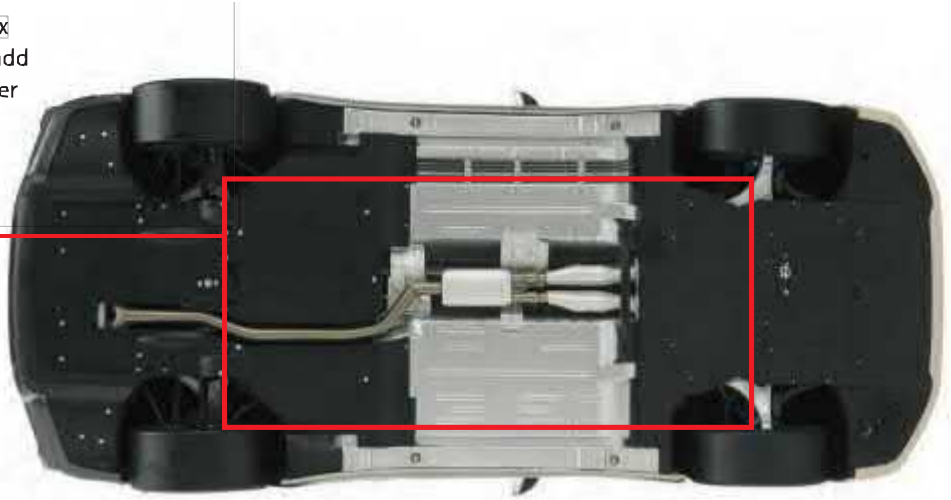

## PARTS LIST



08A



08B



08C



08D

## PART IDENTIFICATION LIST

PART No.	NAME	QUANTITY	MATERIAL
08A	Front Gearbox Section	1	ZINC
08B	Lower Half Shaft	1	ZINC
08C	Lower Gear Shaft (Front)	1	ZINC
08D	Lower Gear Shaft (Rear)	1	ZINC
Screws	Type GM 0.08" x 0.16" [2mm x 4mm]	8 [+4 spares]	METAL

### TIP!

Only two of the GM screws will be used in this build. The rest will be used later.



TYPE GM

## STEP 01 Attach the Front Gearbox Section

Take the Rear Gearbox parts that you have just combined and attach the Front Gearbox Section [08A] to them with two **TYPE GM** screws, as shown in the illustration.

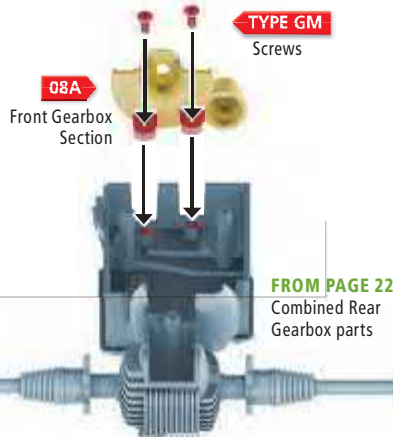

**COLOR KEY**  
■ PART BEING FITTED  
■ PART BEING FITTED TO  
■ FIXINGS



## STEP 02 Attach the Lower Half Shaft

Push the Lower Half Shaft [08B] into the Front Gearbox Section [08A]. This part will be loose, but don't worry, as it will be secured with other parts that come in a future magazine.

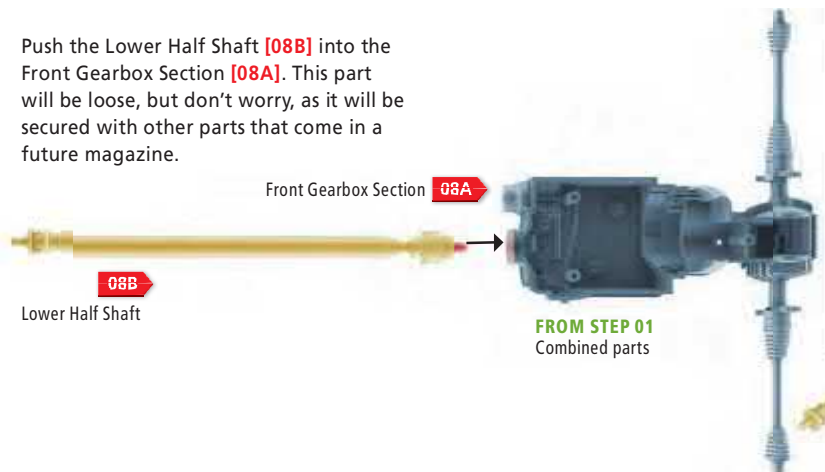

## STEP 03 Attach the Lower Gearshaft (Rear)

Slot the Lower Gearshaft (Rear) [08D] into the other hole in the Front Gearbox Section [08A], as indicated in the illustration. Again, this will remain loose.

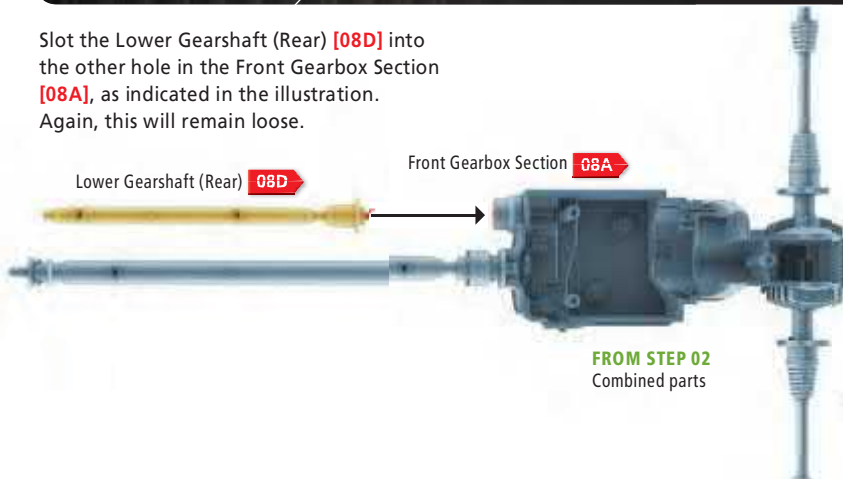

## STEP 04 Attach the Lower Gearshaft (Front)

Join the Lower Gearshaft (Front) [08C] to the Lower Gearshaft (Rear) [08D] by pushing the two parts together, as indicated in the illustration. Again, these parts will be loose and not secured until a later stage of the build.



## Complete!

### You have fitted the Lower Half Shaft and Gearshafts

The Lower Half Shaft and Lower Gearshafts may seem a bit loose at the moment, but don't worry, they will be screwed together at a later stage in the build.

#### TIP!

Make sure that you keep unused screws safe, as they will be used to secure parts later.



## RADIATOR AND WATER TANK

Now let's fit the Radiator Pipe and Cover, the Engine Hose, the Engine Front Cover and Base, and the Water Tank and its Cover to the Engine Room Bay that you received with **Magazine 02**.

### PARTS LOCATION



### PARTS LIST

#### PART IDENTIFICATION LIST

PART No.	NAME	QUANTITY	MATERIAL
09A	Water Tank	1	ABS
09B	Engine Hose	1	ABS
09C	Water Tank Cover	1	ABS
09D	Radiator Pipe	1	ABS
09E	Radiator Pipe Cover	1	ABS
09F	Engine Front Cover	1	ABS
09G	Engine Front Cover Base	1	ABS
09H	Radiator Base with Pattern	1	ABS
Screws	Type HP 0.09" x 0.16" [2.3 x 4mm]	10 [+6 spares]	Metal
Screws	Type BP 0.06" x 0.12" [1.5mm x 3mm]	2 [+2 spares]	Metal



09A



09B



09C

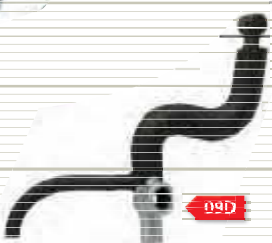

09D



09E

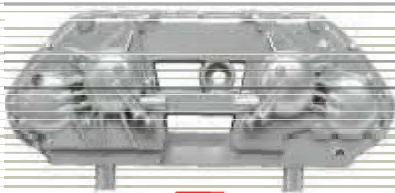

09F

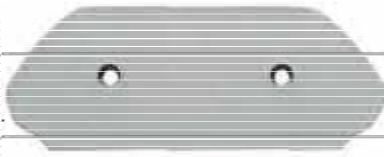

09G

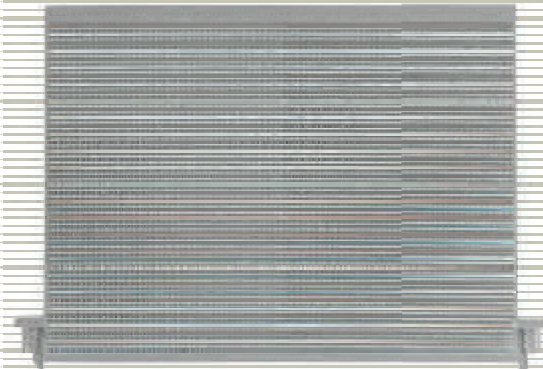

09H

TYPE BP

TYPE HP

**TIP!**  
The Water Tank Cover has a shorter peg than the Radiator Pipe Cover.

## STEP 01

### Attach the Engine Hose to the Water Tank

Place the ring of the Engine Hose [09B] over the hole of the Water Tank [09A], as shown in the illustration, and hold it in place by pushing the Water Tank Cover [09C] into the hole. Make sure that you match the notch in the ring of the Engine Hose to the notch in the Water Tank Cover. Secure the parts together from underneath with a TYPE BP screw, while pressing down on the Water Tank Cover with your finger to keep it in place.



#### COLOR KEY

- PART BEING FITTED
- PART BEING FITTED TO
- FIXINGS

#### STEP 01 COMPLETE



## STEP 02

### Attach the Radiator Pipe to the Engine Hose

Place the ring of the Engine Hose [09B] over the hole of the Radiator Pipe [09D], as shown in the illustration, and hold it in place by pushing the Radiator Pipe Cover [09E] into the hole. Secure the parts together from underneath with a TYPE BP screw.

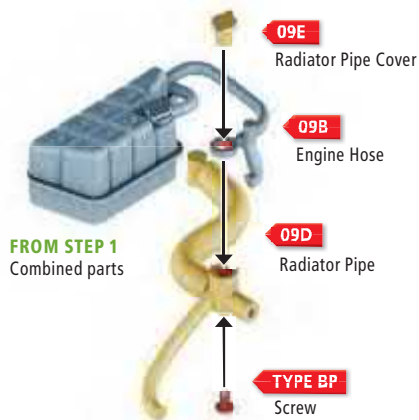

#### STEP 02 COMPLETE



## STEP 03

### Attach the Radiator Pipe to the Engine Front Cover

Slot the Radiator Pipe [09D] into the hole of the Engine Front Cover [09F], as shown in the illustration, and secure it from the other side with a TYPE HP screw.

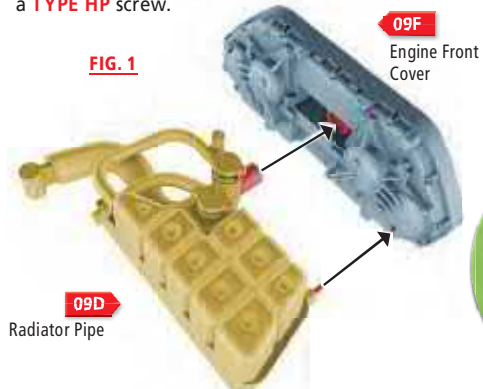

FIG. 2



#### TIP!

The peg on the end of the Radiator Pipe should slot into the small hole on the bottom right of the Engine Front Cover.

#### STEP 03 COMPLETE



## STEP 04 Attach the Engine Front Cover and Base

Place the Engine Front Cover Base [09G] on to the back of the Engine Front Cover [09F], as indicated in the illustration, and secure it with two **TYPE HP** screws.

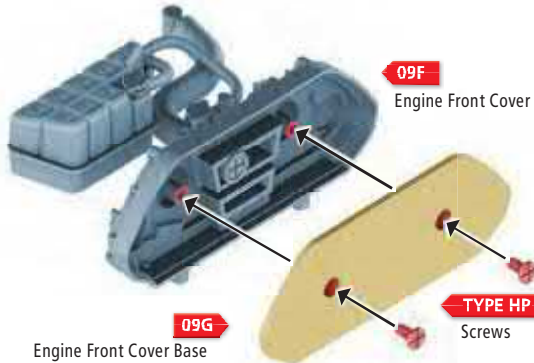

## STEP 05 Attach the combined parts to the Engine Room Bay

Slot the two pegs on the bottom of the combined Engine Front Cover and Base into the holes of the Engine Room Bay that you built in Magazine 02. Now, turn the Engine Room Bay over and use two **TYPE HP** screws

in the center to secure the Engine Front Cover and Base in place. Use two more **TYPE HP** screws in the holes toward the front to secure the Water Tank [09A] and one **TYPE HP** screw at the very front to secure the Radiator Pipe [09D].

FIG. 1

FROM STEP 4  
Combined parts

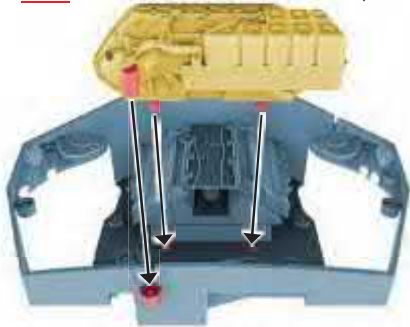
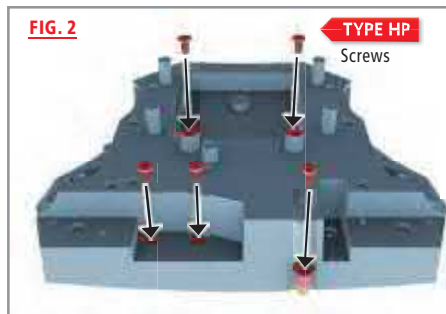

FIG. 2

TYPE HP  
Screws



**TIP!**

The Radiator Pipe should slot into the groove at the front of the Engine Room Bay.

## Complete!

You have now finished with the Radiator and Water Tank parts

Don't worry about the Radiator Base with Pattern for now, as this will connect to engine parts that come with a later magazine.

**TIP!**

Make sure you keep the unused screws safe, as they will be used with parts that come later.



# BUILD THE INTERCOOLER

Now it is time to fit your NISSAN GT-R (R35) model's Intercooler to the Intercooler Base.



**PARTS LOCATION**

## PARTS LIST

### PART IDENTIFICATION LIST

PART No.	NAME	QUANTITY	MATERIAL
<b>10A</b>	Intercooler	1	ABS
<b>10B</b>	Intercooler Base	1	ABS
<b>Screws</b>	Type HP 0.09" x 0.16" [2.3mm x 4mm]	4 [+2 spares]	Metal

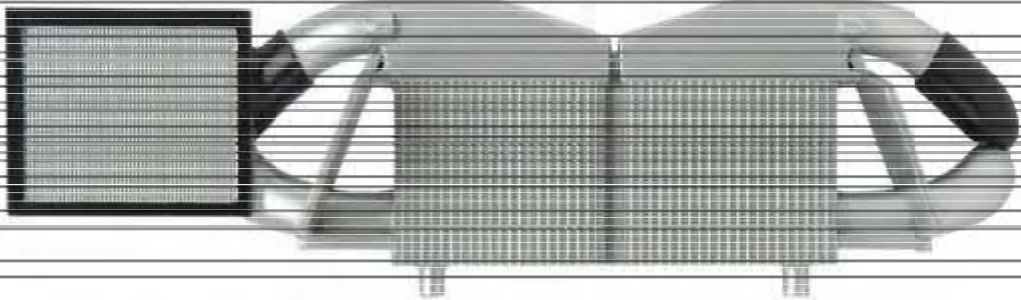

**10A**



**10B**



**TYPE HP**



# HOW TO BUILD

## STEP 01

### Fit the Intercooler Base to the Intercooler

Slot the pegs on the bottom of the Intercooler [10A] into the holes on the Intercooler Base [10B], as shown in the illustration.

#### TIP!

Make sure the Intercooler is the correct way round on the base.

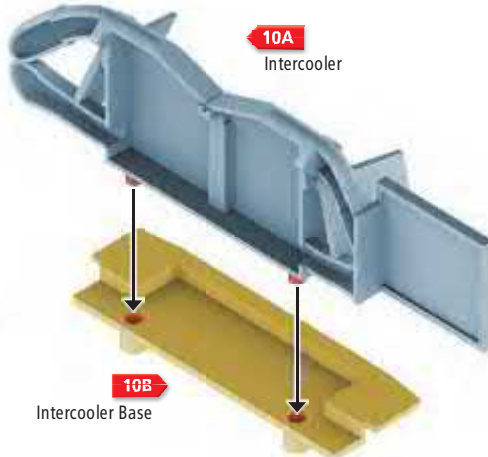

#### COLOR KEY

- PART BEING FITTED
- PART BEING FITTED TO
- FIXINGS

#### STEP 01 COMPLETE

## STEP 02

### Secure the Intercooler to the Intercooler Base

From the underside of the Intercooler Base [10B], use two TYPE HP screws to secure the parts together, as shown in the illustration.

#### TIP!

Make sure that you keep the unused screws somewhere safe.

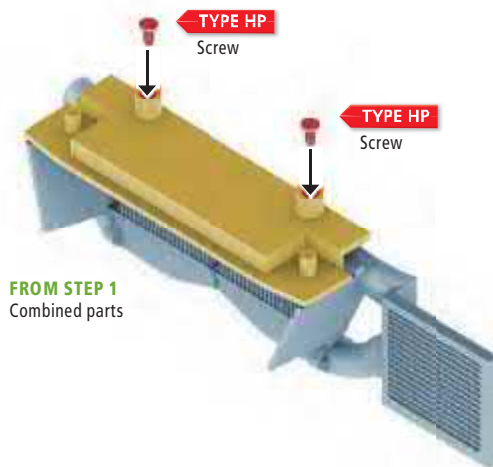

#### STEP 02 COMPLETE

## Complete!

### The Intercooler is finished

Don't worry about the two extra TYPE HP screws for now, as these will be used to connect the Intercooler Base with the rest of the car later.





## REAR LEFT SUSPENSION

In this magazine, you will assemble the Rear Left Suspension of your NISSAN GT-R (R35). The instructions are similar to the ones you followed when building the Rear Right Suspension in **Magazine 02**, but this time there is no Anti Roll Bar.

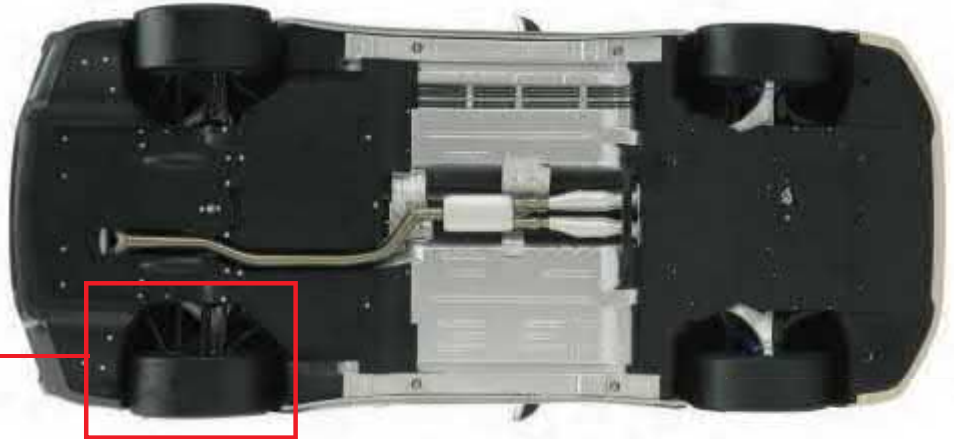

### PARTS LOCATION

### PARTS LIST



11A



11B



11C



11D

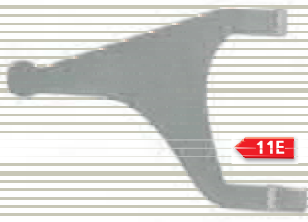

11E



11F



11G



11H



TYPE DM



TYPE EM



NUTS

### PART IDENTIFICATION LIST

PART No.	NAME	QUANTITY	MATERIAL
11A	Upper Mount	1	Zinc
11B	Coil Spring	1	Metal hardware
11C	Stroke	1	Zinc
11D	Knuckle Base	1	Zinc
11E	Upper Join	1	Zinc
11F	Lower Toe Strut Bar (long)	1	Zinc
11G	Lower Toe Strut Bar (short)	1	Zinc
11H	Lower Sway Bar	1	Zinc
Screws	Type DM 0.07" x 0.12" [2mm x 3mm]	1 [+1 spare]	Metal
Screws	Type EM 0.07" x 0.4" [2mm x 10 mm]	4 [+3 spare] + Nuts	Metal

## STEP 01

### Combine the Shock Absorber parts

Insert the Upper Mount [11A] inside the Coil Spring [11B] and then slide the Stroke [11C] through the other end of the Coil Spring. Turn the Stroke so that its peg slides up inside the Upper Mount.

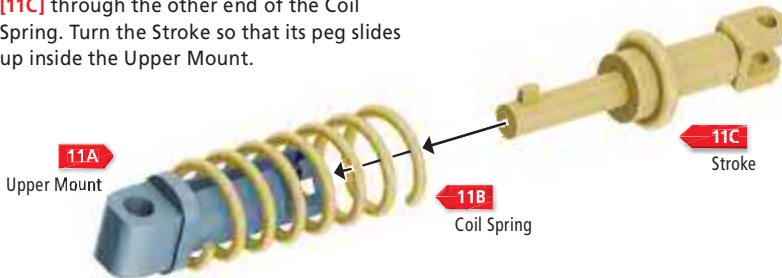

#### COLOR KEY

- PART BEING FITTED
- PART BEING FITTED TO
- FIXINGS

#### STEP 01 COMPLETE



## STEP 02

### Add the Upper Join to the Knuckle Base

Slot the Upper Join [11E] onto the Knuckle Base [11D], as shown in the illustration, and then slide a TYPE EM screw from the top through the holes and secure it from the other side with a nut.

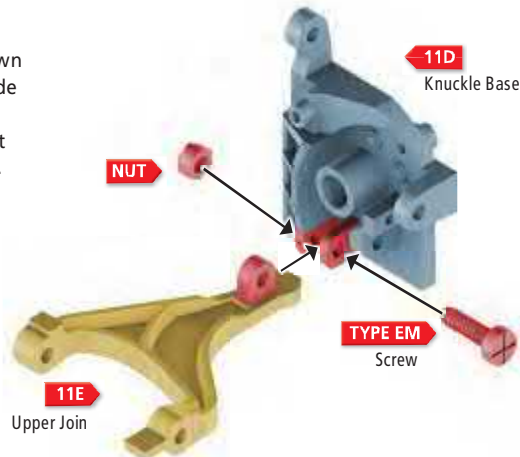

#### STEP 02 COMPLETE



## STEP 03

### Add the combined Upper Mount, Coil Spring and Stroke to the Knuckle Base

FROM STEP 1  
Combined parts

Slot the combined parts from STEP 1 onto the Knuckle Base [11D], as shown in the illustration, and then slide a TYPE EM screw from the top through the holes and secure them from the other side with a nut. Use a magnetic screwdriver to help maneuver the nut into place if you have difficulty.

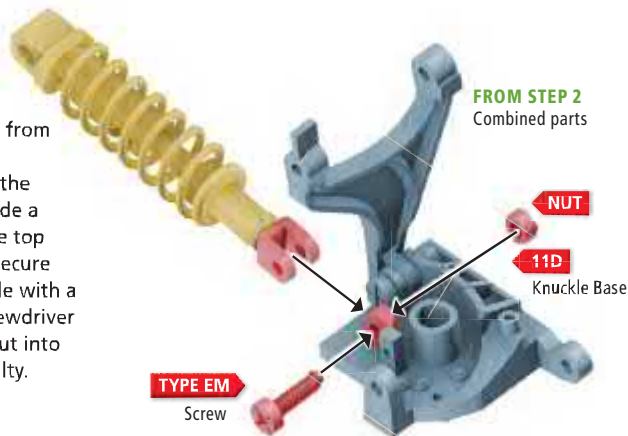

FROM STEP 2  
Combined parts

#### STEP 03 COMPLETE



## STEP 04 Add the Lower Toe Strut Bars (long and short) to the Knuckle Base

Slot the Lower Toe Strut Bar (long) [11F] onto the Knuckle Base [11D], as indicated in the illustration, then slide a **TYPE EM** screw through the holes and secure them with the nut. Now, slot the Lower Toe Strut Bar (short) [11G] onto the Knuckle Base and secure it with a **TYPE EM** screw.

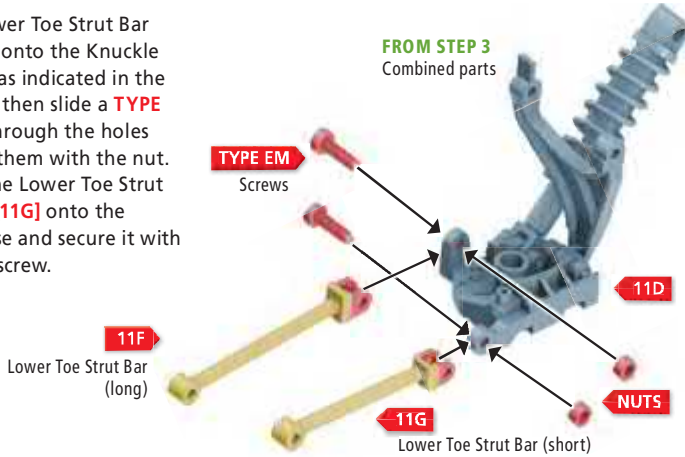

## STEP 05 Attach the Lower Sway Bar to the Knuckle Base

Place the hole of the Lower Sway Bar [11H] onto the Knuckle Base, as shown in the illustration, and secure it with a **TYPE DM** screw from above. Do not screw it in too tightly, as the Lower Sway Bar should be slightly loose.

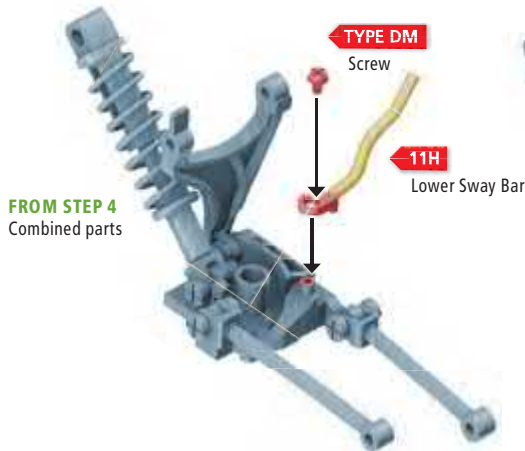

## Complete!

This section of the build is completed.

Well done, you have completed the Rear Left Suspension of your NISSAN GT-R (R35).

These combined parts will be joined to the Brake parts and the Rear Left Wheel and Tire that will come with a later magazine.



# REAR SUSPENSION LOWER MOUNT

Now you will add more parts to your NISSAN GT-R (R35) model's Rear Right Suspension, which you assembled in Magazine 02.

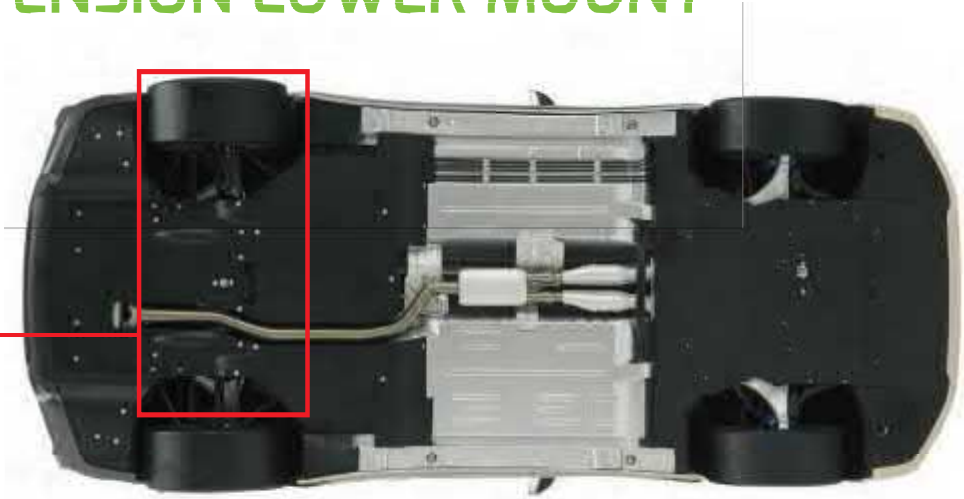

## PARTS LOCATION

## PARTS LIST



12A

12B

12C

12D



12E

12F

12G

12H

12I

### PART IDENTIFICATION LIST

PART No.	NAME	QUANTITY	MATERIAL
12A	Right Clamp Holder	1	ZINC
12B	Left Clamp Holder	1	ZINC
12C	Right U Assembly	1	ZINC
12D	Left U Assembly	1	ZINC
12E	Rear Cross Member	1	ZINC
12F	Right U Assy Clamp	1	ABS
12G	Right U Assy Clamp Base	1	ABS
12H	Left U Assy Clamp	1	ABS
12I	Left U Assy Clamp Base	1	ABS
Screws	Type BP 0.06" x 0.12" [1.5 mm x 3 mm]	4 [+2 spare]	Metal
Screws	Type HP 0.09" x 0.16" [2.3 mm x 4 mm]	2 [+1 spare]	Metal
Screws	Type FM 0.07" x 0.5" [2.0 mm x 13 mm]	4 [+2 spare] + Nuts	Metal
Screws	Type HM 0.09" x 0.16" [2.3 mm x 4 mm]	3 [+3 spare]	Metal
Screws	Type AM 0.1" x 0.16" [2.6 mm x 4 mm]	2 [+1 spare]	Metal

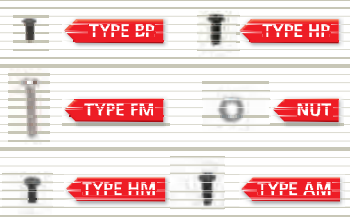

## STEP 01 Attach the Right Clamp Holder

**COLOR KEY**  
 ■ PART BEING FITTED  
 ■ PART BEING FITTED TO  
 ■ FIXINGS

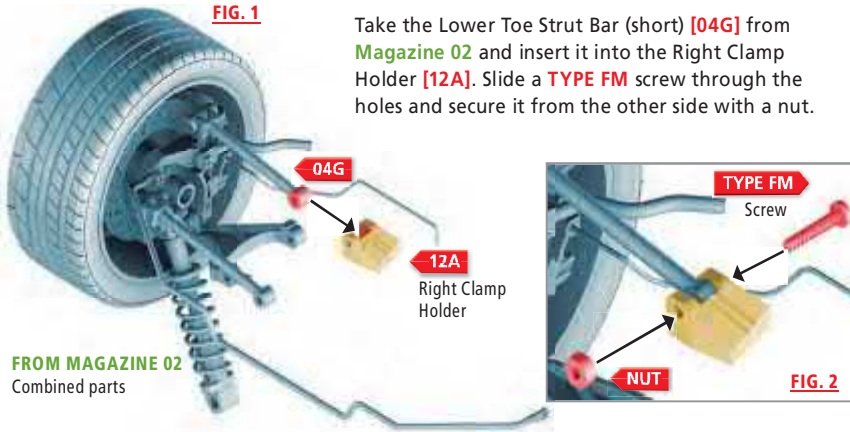

## STEP 02 Attach the Left and Right U Assemblies

Slot the Right U Assembly [12C] onto the right side of the Rear Cross Member [12E] and the Left U Assembly [12D] onto the left side and secure them from above with TYPE AM screws.



## STEP 03 Attach the Left Clamp Holder

Take the Lower Toe Strut Bar (short) [11G] that came with this magazine and insert it into the Left Clamp Holder [12B]. Slide a TYPE FM screw through the holes and secure it from the other side with a nut.

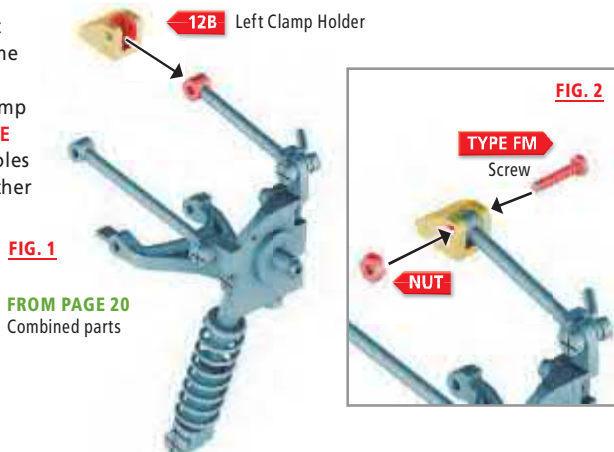

## STEP 04

### Add the U Assy Clamp Holders and Bases

Place the Anti Roll Bar [04I] from Magazine 02 between the U Assy Clamps and Bases, as indicated in the illustration, and secure the parts together with TYPE BP screws.

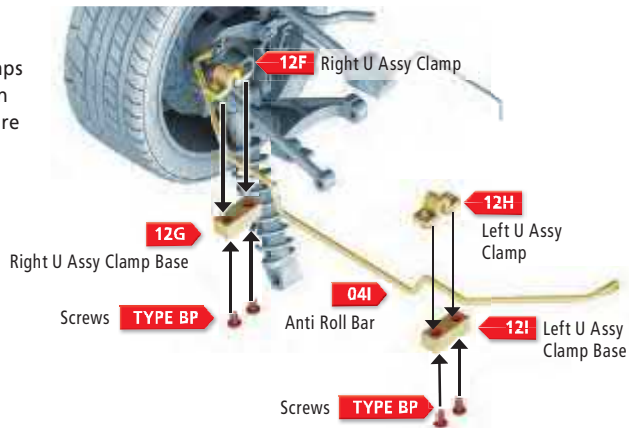

## STEP 05

### Attach the U Assy Clamp Bases to the Rear Cross Member

Slot both sides of the combined U Assy Clamps and Bases onto the Rear Cross Member [12E]. Secure these parts together from underneath with TYPE HP screws.

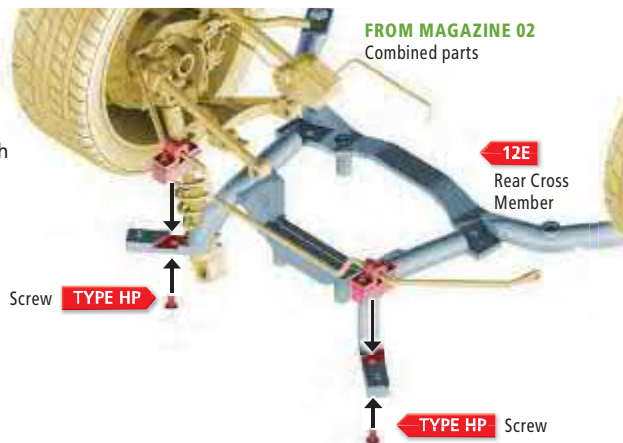

## STEP 06

### Attach the Left and Right Suspension parts to the U Assemblies

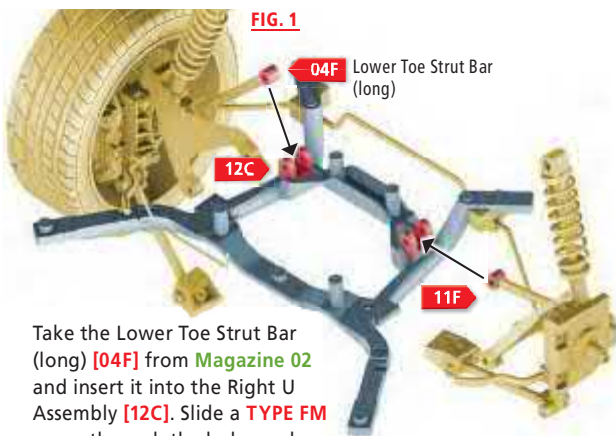

Take the Lower Toe Strut Bar (long) [04F] from Magazine 02 and insert it into the Right U Assembly [12C]. Slide a TYPE FM screw through the holes and fasten with a nut.

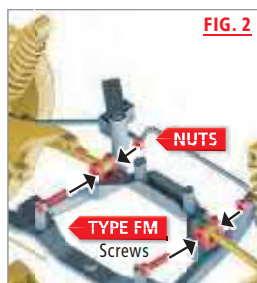

Now, do the same on the left side with the Lower Toe Strut Bar (long) [11F] from Page 18.





## STEP 07 Attach the Clamp Holders to the Rear Cross Member

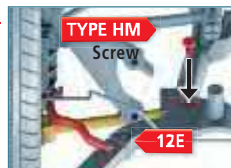
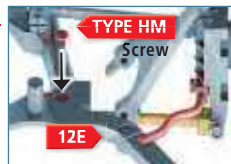
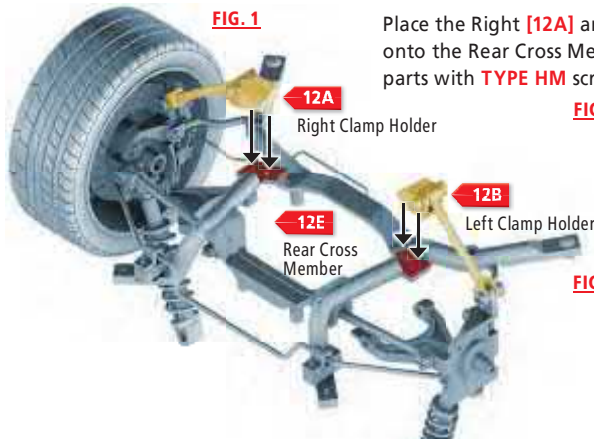

## STEP 08 Secure the Anti Roll Bar to the Knuckle Base

Secure the Anti Roll Bar [04I] to the Knuckle Base [11D] on the left side with a TYPE DM screw that came with Magazine 02.

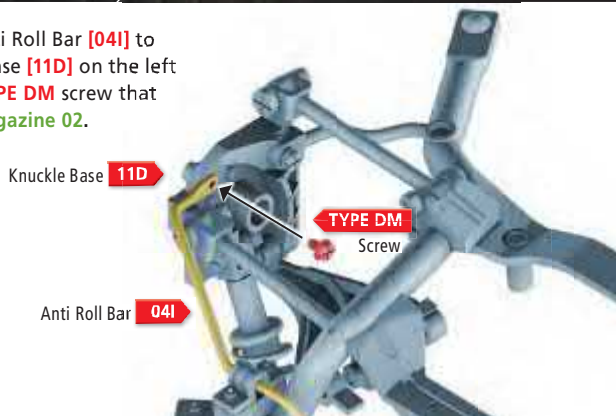

## Complete!

You have completed the Rear Suspension Lower Mount parts.

This combined section will be joined to the Rear Suspension Upper Mount.

### TIP!

One of the TYPE HM screws from this pack will be used on Page 28.



# REAR SUSPENSION UPPER MOUNT

Now you will fit together more parts of the Rear Suspension and then combine them with parts you received in Magazine 02, Magazine 03 and this magazine.

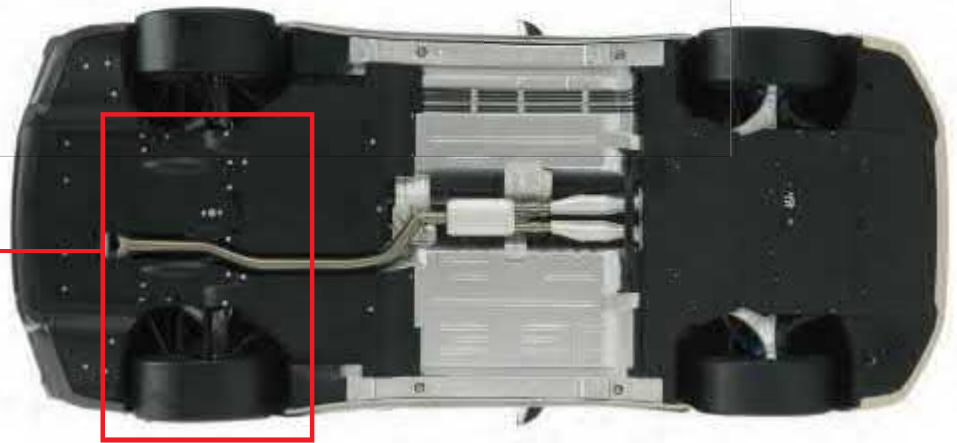

**PARTS LOCATION**

## PARTS LIST

### PART IDENTIFICATION LIST

PART No.	NAME	QUANTITY	MATERIAL
13A	Upper Mount	1	ZINC
13B	Big Join Clamp (right)	1	ZINC
13C	Big Join Clamp (left)	1	ZINC
13D	Small Join Clamp (right)	1	ZINC
13E	Small Join Clamp (left)	1	ZINC
Screws	Type AM 0.1" x 0.16" [2.6 mm x 4 mm]	12 [+7 spare]	Metal
Screws	Type FM 0.08" x 0.5" [2 mm x 13 mm]	4 [+2 spare] + Nuts	Metal



13A



13B



13C



13D



13E



NUT



TYPE FM



TYPE AM

## STEP 01 Attach the Big and Small Join Clamps

**COLOR KEY**  
■ PART BEING FITTED  
■ PART BEING FITTED TO  
■ FIXINGS

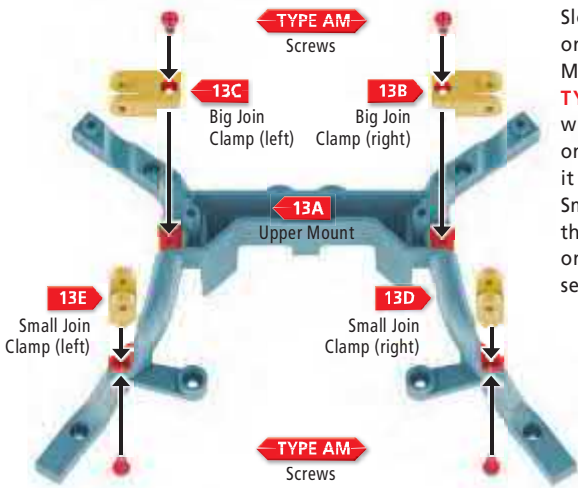

Slot the Big Join Clamp (right) [13B] onto the right side of the Upper Mount [13A] and secure it with a TYPE AM screw. Now do the same with the Big Join Clamp (left) [13C] on the left side and again secure it with a TYPE AM screw. Slot the Small Join Clamp (right) [13D] and the Small Join Clamp (left) [13E] onto the Upper Mount [13A] and secure them with TYPE AM screws.



## STEP 02 Attach the Upper Mount to the Rear Cross Member

FIG. 1

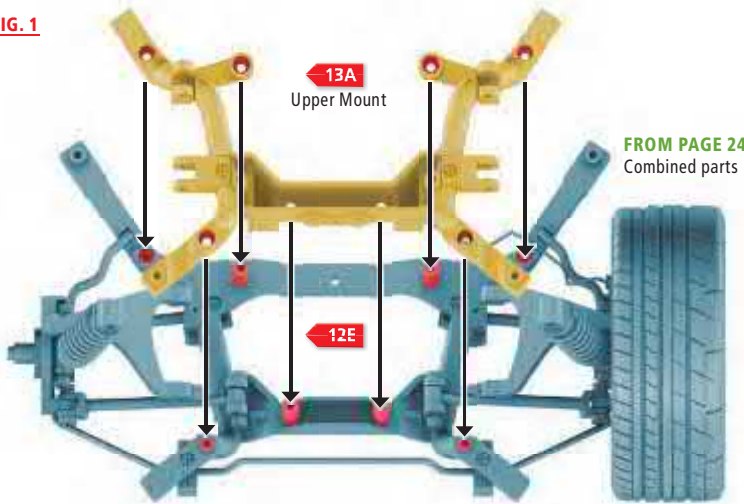

Place the Upper Mount [13A] onto the combined parts of the Rear Cross Member [12E] from Page 24, lining up the holes as shown in the illustration. Make sure that the Brake Cable [03D] on the right passes through the small hole between the Upper Mount and Rear Cross Member, while the Lower Sway Bars [04H/11H] on both sides fit through the larger holes between the Upper Mount and Rear Cross Member – see FIG. 2 and FIG. 3.

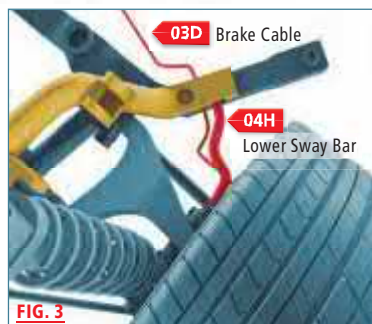
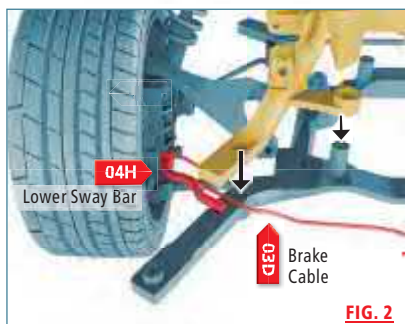

### STEP 03

#### Secure the Upper Mount to the Rear Cross Member

Use **TYPE AM** screws in all 8 of the holes indicated in the illustration below to secure the parts together.

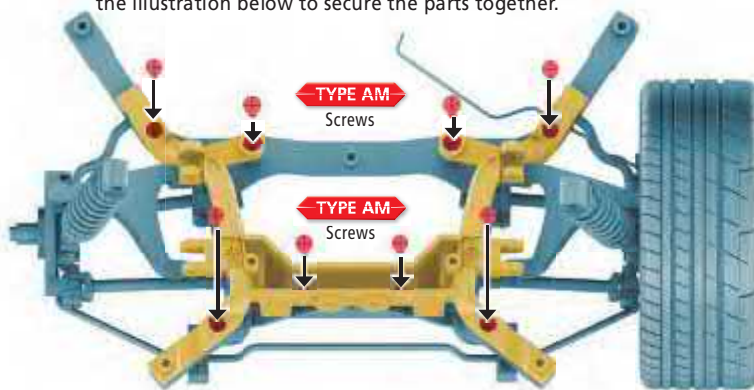

STEP 03 COMPLETE



### STEP 04

#### Attach the Upper Join from Magazine 02

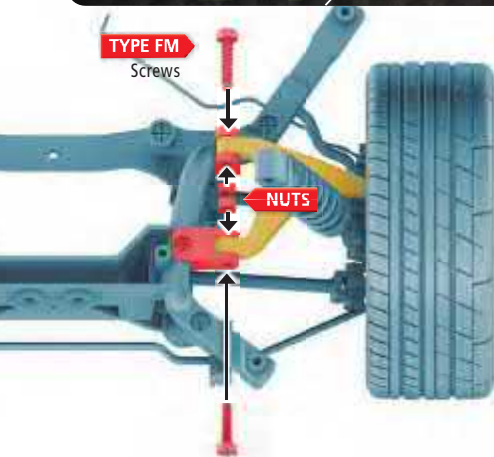

Take the Upper Join [04E] from Magazine 02 and slot it into the Big Join Clamp (right) [13B]. Slide a **TYPE FM** screw through the holes and secure the parts together from the other side with a nut. Now, slot the other arm of the Upper Join [04E] into the Small Join Clamp (right) [13D] and slide a **TYPE FM** screw through the holes and secure the parts from the other side with a nut.

STEP 04 COMPLETE



### STEP 05

#### Attach the Upper Join from Page 20

Take the Upper Join [11E] from Page 20 and slot it into the Big Join Clamp (left) [13C]. Slide a **TYPE FM** screw through the holes and secure the parts together from the other side with a nut. Now, slot the other arm of the Upper Join [11E] into the Small Join Clamp (left) [13E] and slide a **TYPE FM** screw through the holes and secure the parts from the other side with a nut.

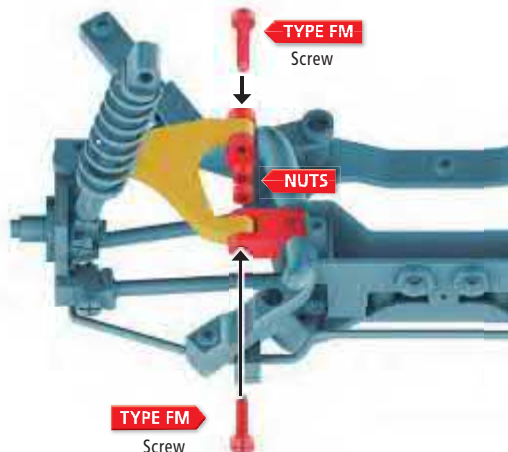

STEP 05 COMPLETE



## STEP 06

Add the Right and Left Rear Half Shafts from Magazine 03

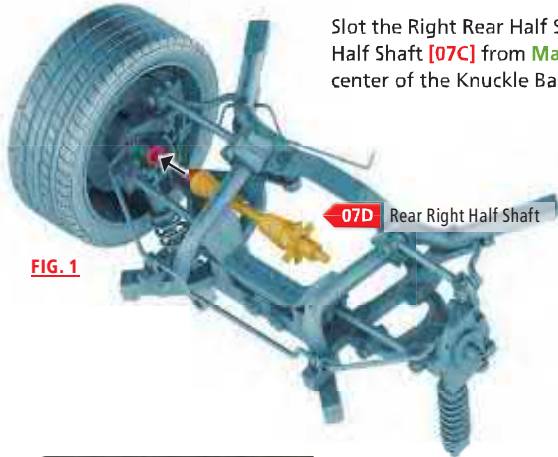

Slot the Right Rear Half Shaft [07D] and the Left Rear Half Shaft [07C] from Magazine 03 into the holes in the center of the Knuckle Bases – there is no need for screws.

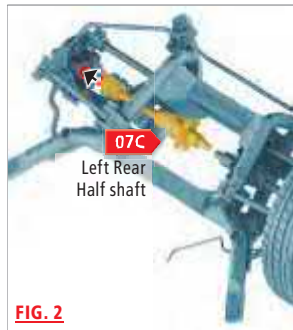

## STEP 07

Attach the Rear Gearbox from Magazine 03

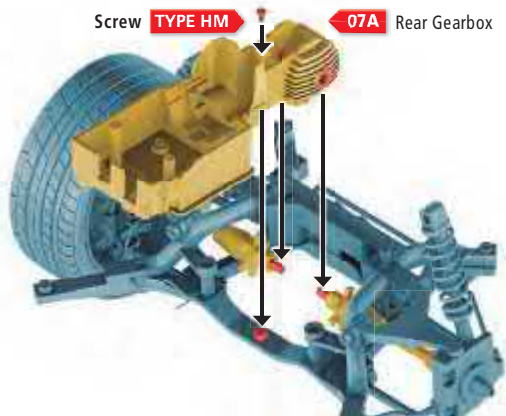

Angle the Half Shafts downward and manipulate them into the side holes of the Rear Gearbox [07A] from Magazine 03. Now slot the Rear Gearbox onto the peg of the Rear Cross Member. Finally, secure the Rear Gearbox with a TYPE HM screw from above.



## Complete!

The Rear Suspension Upper Mount and Lower Mount are combined.

Don't worry that some of the Rear Suspension parts are not yet attached. They will be combined with parts that come later.

### TIP!

One of the Type HM screws from this magazine will be used later, so keep it safe.



# THE FRONT DIFFUSER PANEL

With this magazine, you also received the Front Diffuser Panel for your NISSAN GT-R (R35). There are no assembly instructions for this part yet, so keep it in a safe place until it is needed.

## PARTS LOCATION

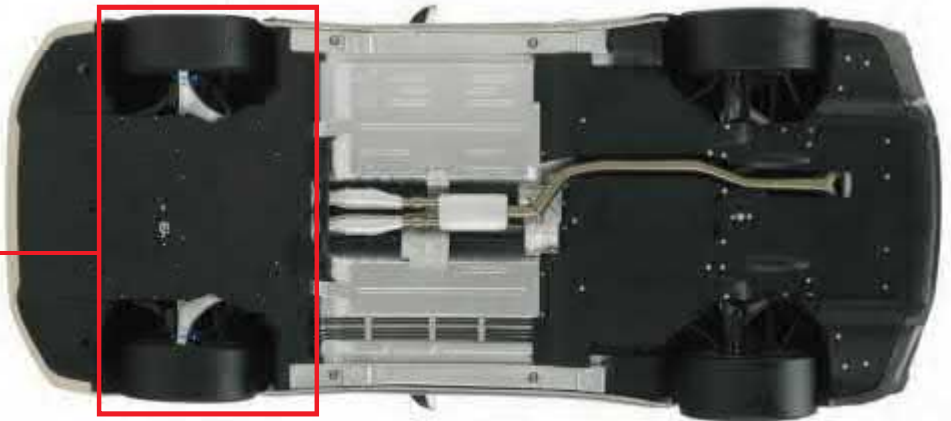

## PARTS LIST

### PART IDENTIFICATION LIST

PART No.	NAME	QUANTITY	MATERIAL
14A	Front Diffuser Panel	1	ABS
Screws	Type HP 0.1" x 0.15" [2.3 mm x 4 mm]	4 [+2 spare]	Metal

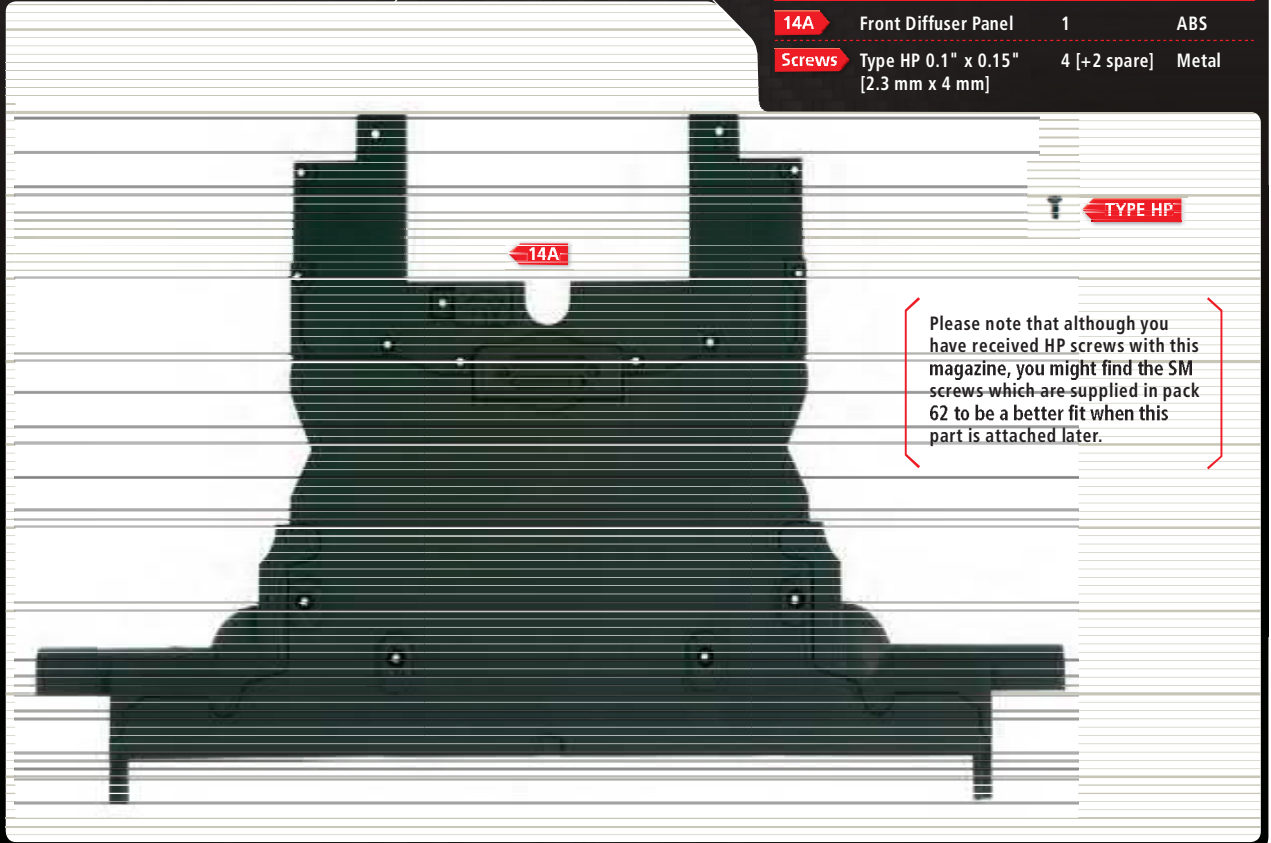

Please note that although you have received HP screws with this magazine, you might find the SM screws which are supplied in pack 62 to be a better fit when this part is attached later.

# HOW TO BUILD

## THE REAR EXHAUST

In this magazine, you will build the parts of your NISSAN GT-R (R35) model's Rear Exhaust. In the real car, the exhaust gases are expelled from these twin quad-tipped exhausts, emitting a powerful and distinctive sound.



**PARTS LOCATION**

### PARTS LIST

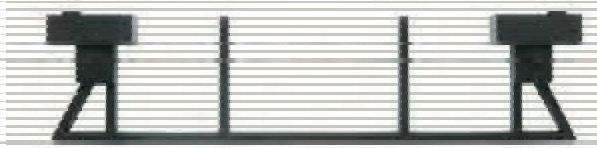

15A



15B

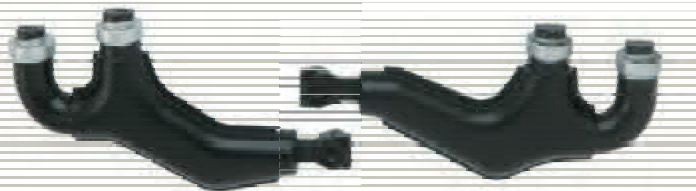

15C

15D

### PART IDENTIFICATION LIST

PART No.	NAME	QUANTITY	MATERIAL
15A	Rear Exhaust Holder	1	ABS
15B	Rear Exhaust Middle Section	1	ABS
15C	Left Rear Exhaust Section	1	ABS
15D	Right Rear Exhaust Section	1	ABS
15E	Left Rear Exhaust Big Cover	1	ABS
15F	Left Rear Exhaust Small Cover	1	ABS
15G	Right Rear Exhaust Big Cover	1	ABS
15H	Right Rear Exhaust Small Cover	1	ABS
Screws	Type GP 0.07 x 0.15" [2 x 4 mm]	10 [+4 spare]	Metal



15E

15F

15G

15H

### TIP!

The parts 15C to 15H have the letters 'L' or 'R' printed on the back, indicating Left or Right.



TYPE GP

## STEP 01

### Attach the Left and Right Rear Exhaust Small Covers

#### COLOR KEY

- PART BEING FITTED
- PART BEING FITTED TO
- FIXINGS

Push the Right Rear Exhaust Small Cover [15H] onto the outside part of Right Rear Exhaust Section [15D], as indicated in FIG.1. Now, push the Left Rear Exhaust Small Cover [15F] onto the outside part of the Left Rear Exhaust Section [15C] (FIG.2). These parts just push into place and there is no need for screws.

FIG. 1



#### TIP!

The Rear Exhaust Small Covers go on the outside.

FIG. 2



## STEP 02

### Attach the Left and Right Rear Exhaust Big Covers

Push the Right Rear Exhaust Big Cover [15G] onto the inside part of Right Rear Exhaust Section [15D] as indicated in FIG.1. Now, push the Left Rear Exhaust Big Cover [15E] onto the inside part of Left Rear Exhaust Section [15C] (FIG.2). Again, these parts just push into place and there is no need for screws.

FIG. 1



FIG. 2

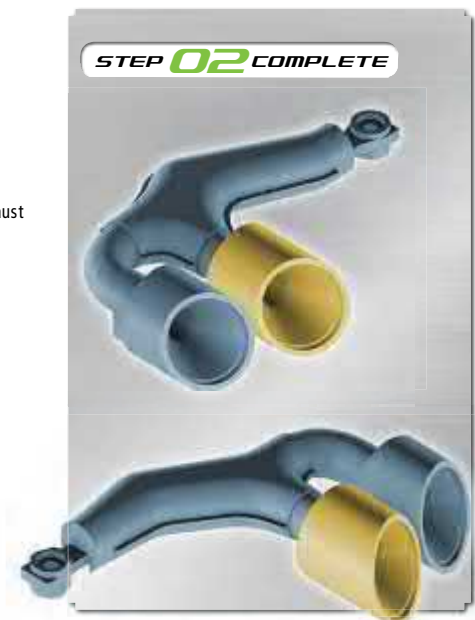
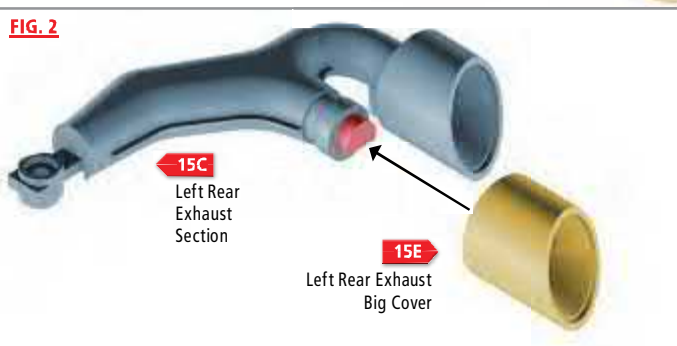



## STEP 03 Attach the Left Rear Exhaust Section to the Rear Exhaust Middle Section

Slot the end of the Left Rear Exhaust Section [15C] onto the front hole of the Rear Exhaust Middle Section [15B], as shown in the illustration. Secure the parts together with a **TYPE GP** screw.

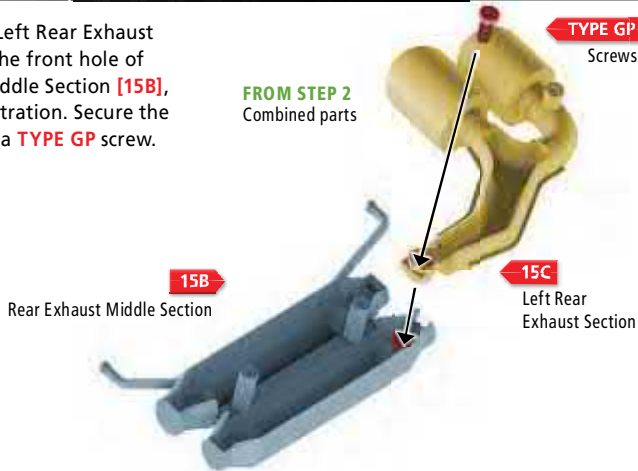

## STEP 04 Attach the Right Rear Exhaust Section to the Rear Exhaust Middle Section

Slot the end of the Right Rear Exhaust Section [15D] onto the rear hole of the Rear Exhaust Middle Section [15B], as shown in the illustration. Secure the parts together with a **TYPE GP** screw.

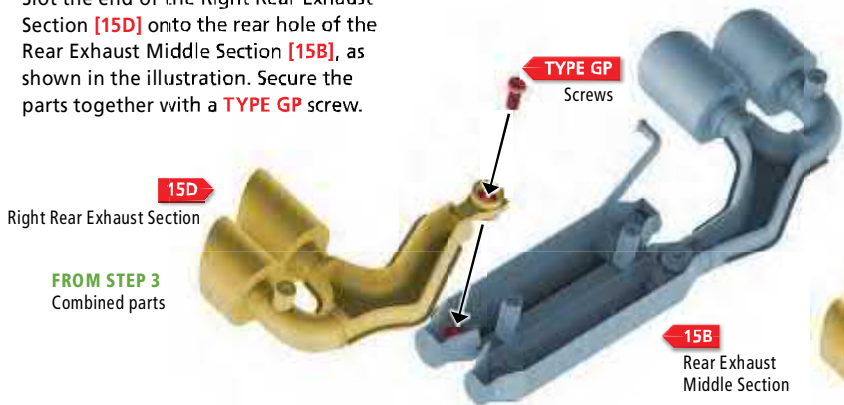

## Complete! The Rear Exhaust Section

Don't worry about the Rear Exhaust Holder [15A] and the rest of the **Type GP** screws for now, as they will be joined to other parts later.

### TIP!

Keep the Rear Exhaust Holder and unused **Type GP** screws safe.



# ENGINE INTAKE PIPES

Now you will add more parts to your NISSAN GT-R (R35) model's Engine Room Bay, which you began assembling in Magazine 02.

## PARTS LOCATION



## PARTS LIST

### PART IDENTIFICATION LIST

PART No.	NAME	QUANTITY	MATERIAL
16A	Air Cond Rail	1	ABS
16B	Long Air Cond Rail	1	ABS
16C	L-shape Air Cond Rail	1	ABS
16D	Left Engine Soft Pipe	1	ABS
16E	Right Engine Soft Pipe	1	ABS
16F	Power Steering Cover	1	ABS
16G	Power Steering Pump	1	ABS
16H	Left Intake Pipe	1	ABS
16I	Right Intake Pipe	1	ABS
16J	Engine Oil Ruler	1	ABS
Screws	Type BP 0.06 x 0.12" [1.5 x 3 mm]	10 [+6 spare]	Metal
Screws	Type GP 0.07 x 0.15" [2 x 4 mm]	5 [+2 spare]	Metal

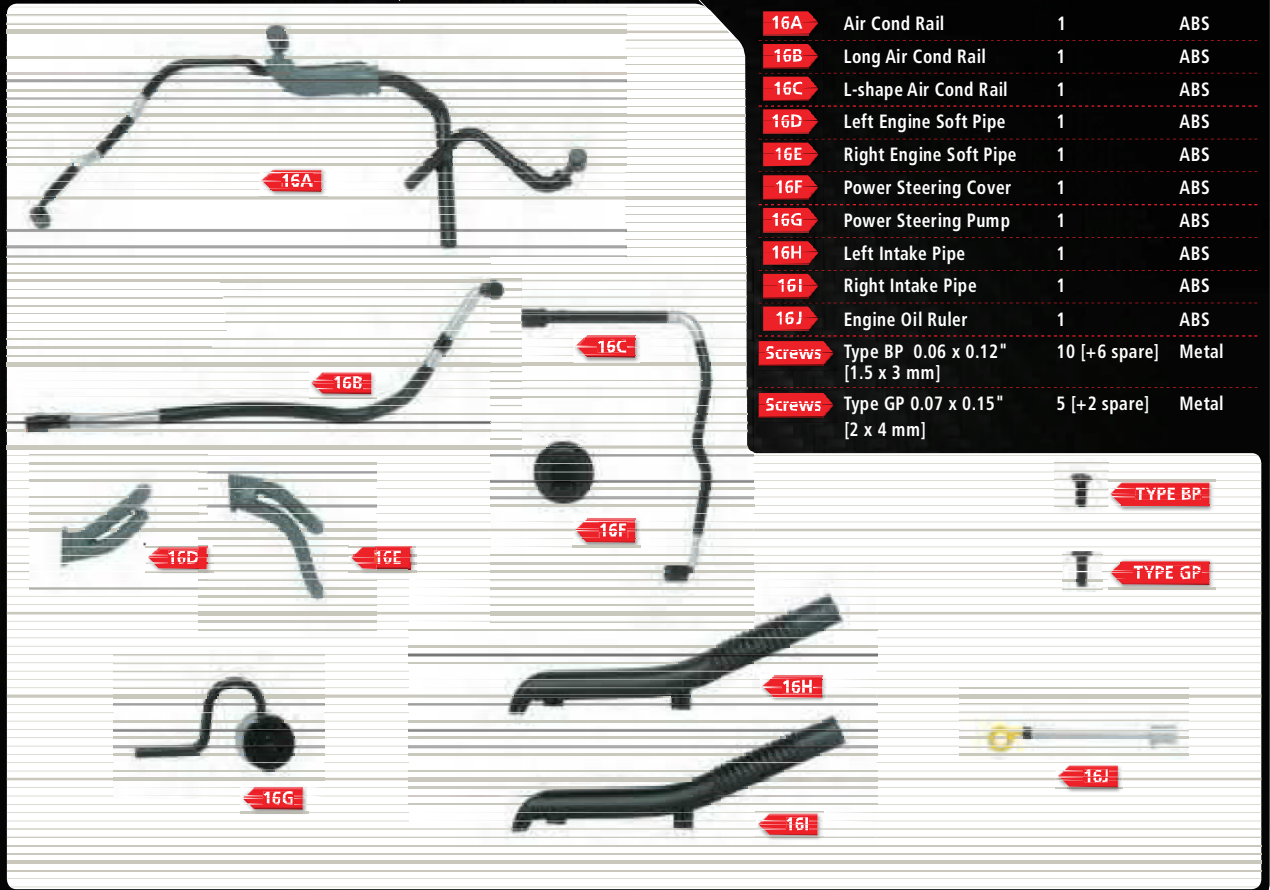

## STEP 01 Attach the Intake Pipes

Slot the pegs on the Left Intake Pipe [16H] and the Right Intake Pipe [16I] into the holes indicated on the Engine Room Bay [06E] and secure them from underneath with 4 Type GP screws.

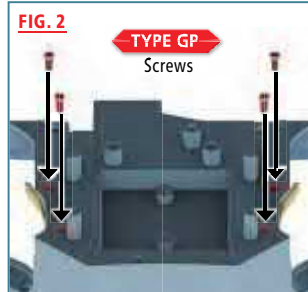
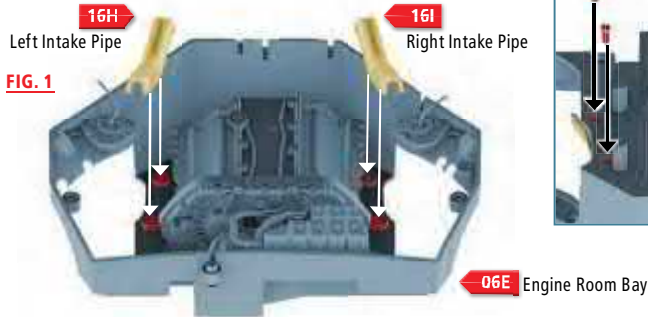

**COLOR KEY**  
 ■ PART BEING FITTED  
 ■ PART BEING FITTED TO  
 ■ FIXINGS



## STEP 02 Attach the Power Steering Pump and Cover

Push the Power Steering Pump [16G] onto the notch at the front of the Engine Room Bay [06E], ensuring that the pipe fits into the hole on the Engine Front Cover. Secure the Power Steering Pump [16G] from underneath with a Type GP screw. Now, click the Power Steering Cover on top.

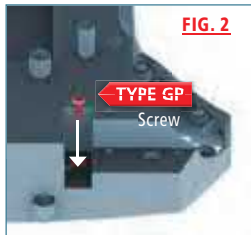
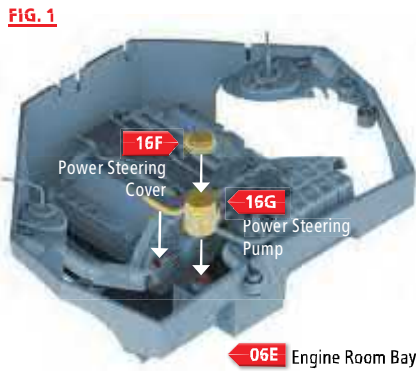

## STEP 03 Attach the Left Engine Soft Pipe

Push the Left Engine Soft Pipe [16D] into the hole, as indicated in the illustration, so that it holds down the cable attached to the Engine Room Bay [06E] in the groove. The ends of the Left Engine Soft Pipe slot into the two notches. Secure the Left Engine Soft Pipe from underneath using a Type BP screw.

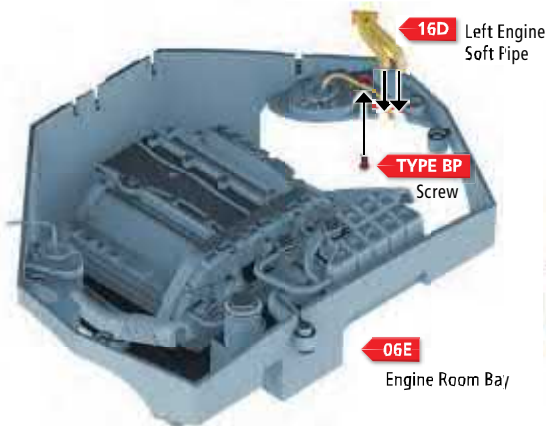

## STEP 04

### Attach the Right Engine Soft Pipe

Push the Right Engine Soft Pipe [16E] into the hole indicated, so that it holds down the cable attached to the Engine Room Bay [06E] and the ends of the Right Engine Soft Pipe slot into the two notches. Secure it from below with a TYPE BP screw.

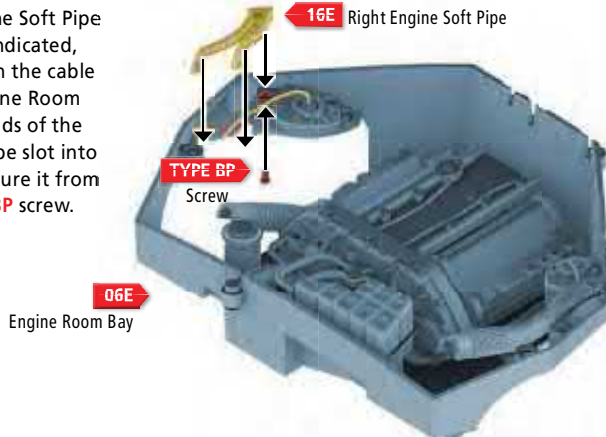

## STEP 05

### Attach the Long Air Cond Rail

Slot one end of the Long Air Cond Rail [16B] into the hole at the back of the Engine Room Bay [06E] and the other end into the hole at the front. Use a TYPE BP screw at either end to secure it.

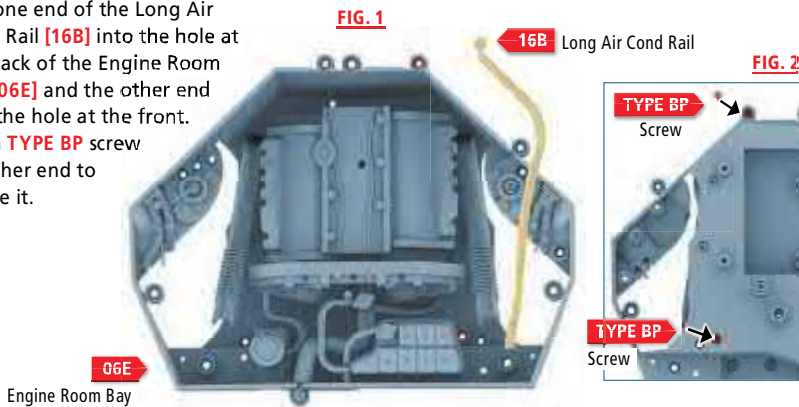

## STEP 06

### Attach the L-shape Air Cond Rail

Slot one end of the L-shape Air Cond Rail [16C] into the hole at the back of the Engine Room Bay [06E] and the other end into the other indicated hole. Use two TYPE BP screws from underneath to secure it in place.

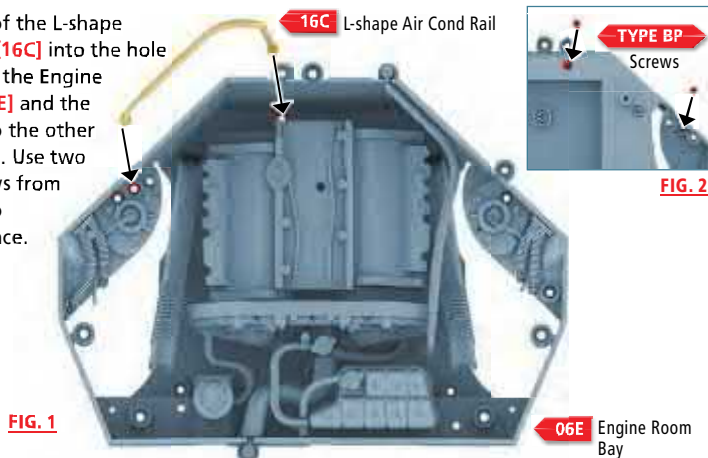

## STEP 07 Attach the Air Cond Rail

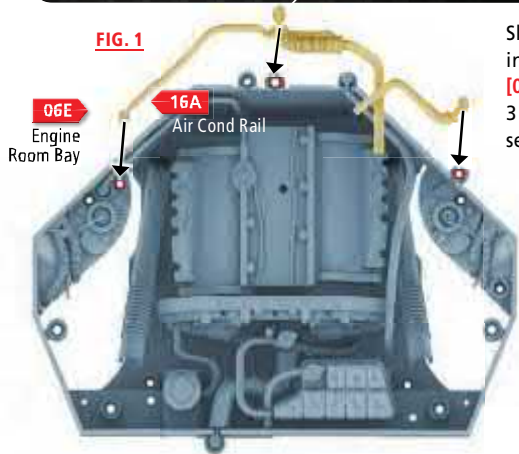

Slot the pegs on the Air Cond Rail [16A] into the 3 holes of the Engine Room Bay [06E], as shown in the illustration. Insert 3 TYPE BP screws from underneath to secure it in place.

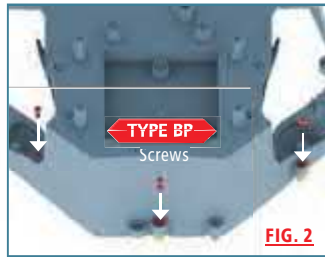

## STEP 08 Add the Engine Oil Ruler

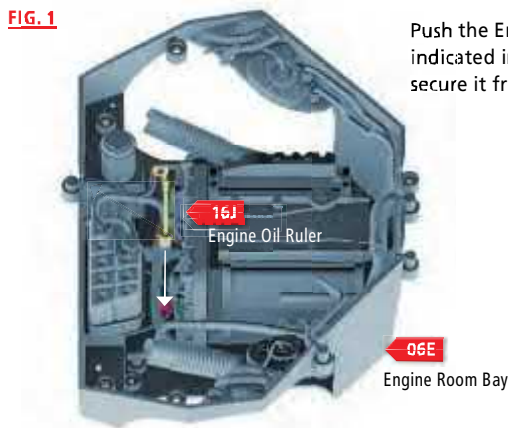

Push the Engine Oil Ruler [16J] into the hole indicated in the Engine Room Bay [06E] and secure it from underneath with a TYPE BP screw.

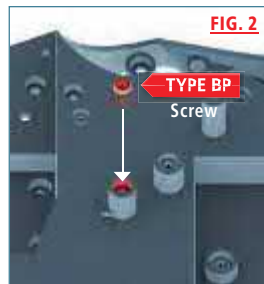

## Complete! The Engine Pipes are completed

This stage of the engine build is completed, but more parts will be added to the Engine Room Bay over the next few pages.



# ENGINE PARTS

Now you will add more parts to your model's Engine Room Bay.

## PARTS LOCATION



## PARTS LIST

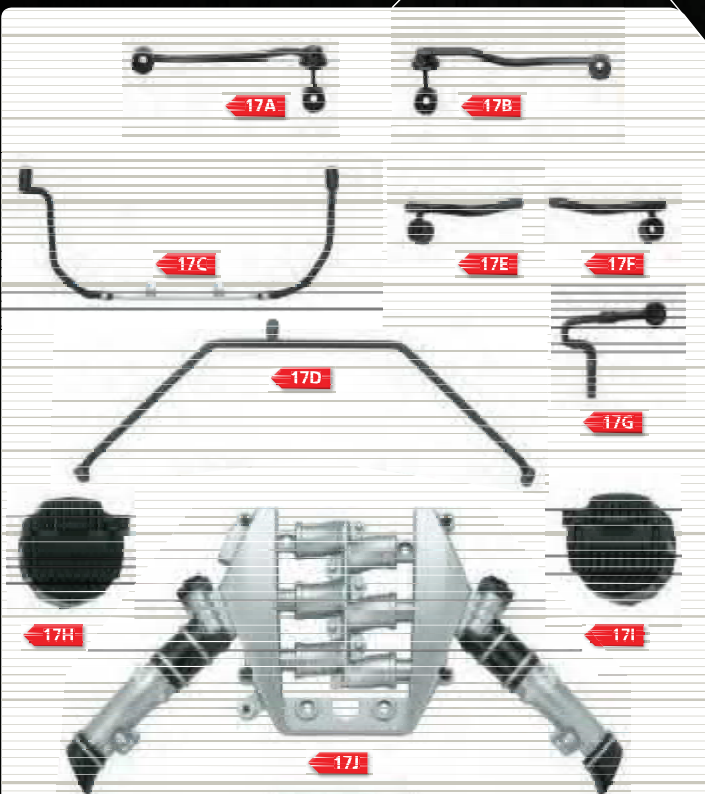

### PART IDENTIFICATION LIST

PART No.	NAME	QUANTITY	MATERIAL
17A	Left Engine Hose	1	ABS
17B	Right Engine Hose	1	ABS
17C	Engine Front Hose	1	ABS
17D	Engine Room Tower Bar	1	ABS
17E	Left Actuator Side Hose	1	ABS
17F	Right Actuator Side Hose	1	ABS
17G	Engine Oil Cap Lower Hose	1	ABS
17H	Left Air Filter Box	1	ABS
17I	Right Air Filter Box	1	ABS
17J	Manifold With Intake Pipe	1	ABS
17K	Manifold Intake Middle Section	1	ABS
17L	Middle Section Nissan Logo	1	ABS
17M	Engine Oil Cover	1	ABS
17N	Spray Tank Cover	1	ABS
Screws	Type BP 0.06 x 0.12" [1.5 x 3 mm]	18 [+7 spare]	Metal
Screws	Type DP 0.09 x 0.12" [2.3 x 3 mm]	4 [+4 spare]	Metal

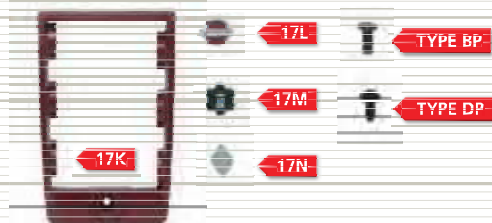

## STEP 01 Attach the Spray Tank Cover

Push the peg on the Spray Tank Cover [17N] into the hole on the Engine Room Bay [06E], as indicated in the illustration. Line up the notch on the cover with the recess on the bay. Use a **TYPE BP** screw on the underside to secure it in place.



**COLOR KEY**  
 ■ PART BEING FITTED  
 ■ PART BEING FITTED TO  
 ■ FIXINGS



## STEP 02 Attach the Engine Front Hose

Slot the two ends of the Engine Front Hose [17C] into the two holes indicated in the illustration and secure it from underneath with two **TYPE BP** screws.

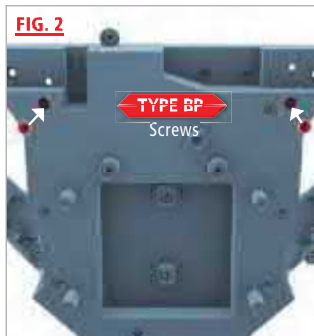
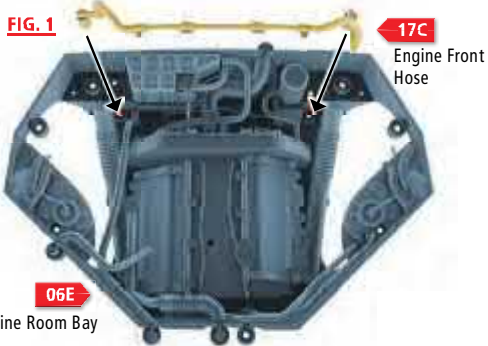

## STEP 03 Attach the Air Filter Boxes

Slot the Left and Right Air Filter Boxes [17H/17I] onto the two pegs at the front of the Engine Room Bay [06E], one on each side. Secure each one from underneath with a **TYPE DP** screw.

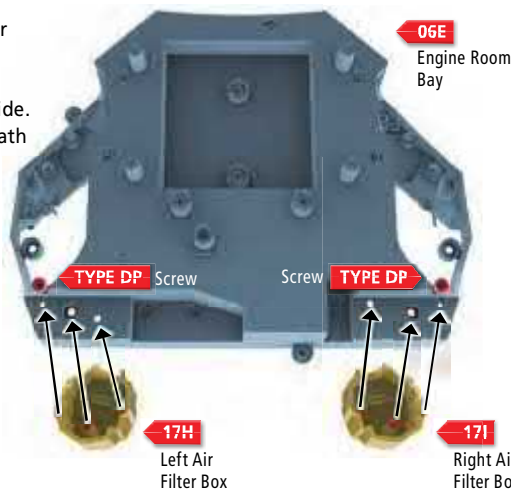

## STEP 04 Attach the Manifold Intake Middle Section

FIG. 1

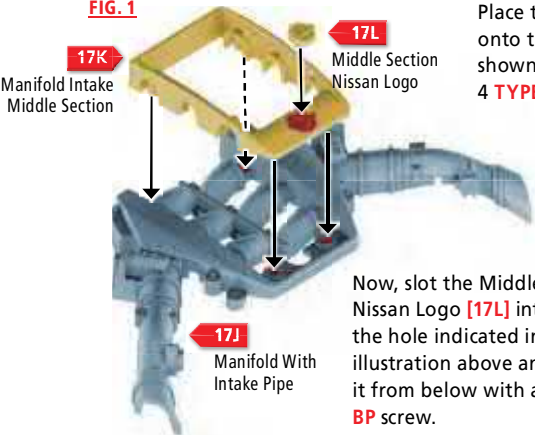

Place the Manifold Intake Middle Section [17K] onto the Manifold With Intake Pipe [17J], as shown left, and secure it from underneath with 4 TYPE BP screws.

Now, slot the Middle Section Nissan Logo [17L] into the hole indicated in the illustration above and secure it from below with a TYPE BP screw.

FIG. 2

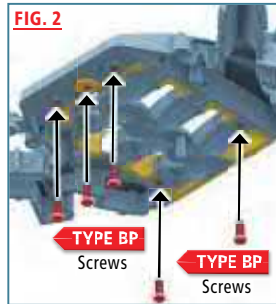

## STEP 05 Attach the Engine Hoses

Slot the Left and Right Engine Hoses [17A/17B] into the holes indicated below on the back of the Manifold With Intake Pipe [17J] and secure them with 4 TYPE BP screws.

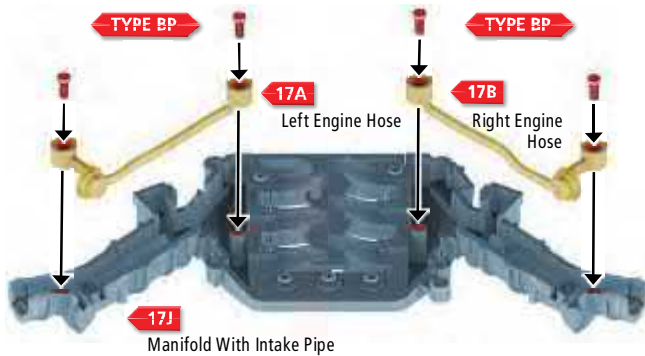

**TIP!**

Parts 17A and 17B are different, so take care not to mix them up.



## STEP 06 Attach the Engine Oil Cap Lower Hose

Slot the round end of the Engine Oil Cap Lower Hose [17G] over the hole on the back of the Manifold With Intake Pipe [17J] and secure it with a TYPE BP screw, while ensuring that the peg on the hose goes into the hole indicated below.

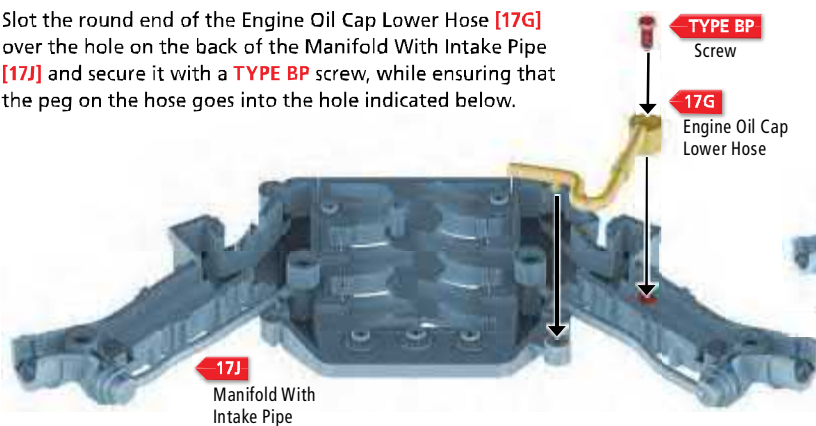



## STEP 07 Attach the Actuator Side Hoses

Place the Left and Right Actuator Side Hoses [17E/17F] over the holes indicated on the back of the Manifold With Intake Pipe [17J] and secure each one with a **TYPE BP** screw.



## STEP 08 Attach the Engine Room Tower Bar

Slot the Engine Room Tower Bar [17D] onto the 3 holes indicated in the illustration and secure it with 3 **TYPE BP** screws.

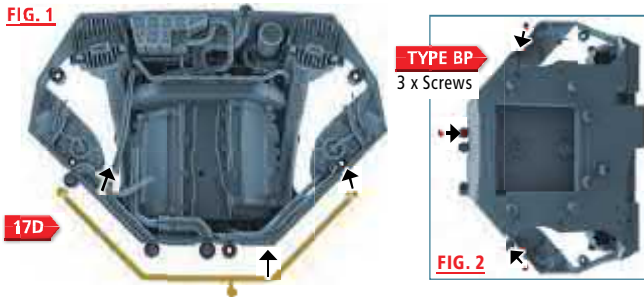

## STEP 09 Attach the Manifold With Intake Pipe and Engine Oil Cover

Place the Manifold With Intake Pipe [17J] onto the indicated holes. Secure it from below with two **TYPE DP** screws. Push the Engine Oil Cover [17M] into the hole on the Manifold With Intake Pipe [17J]. It just pushes into place and there is no need for any screws.

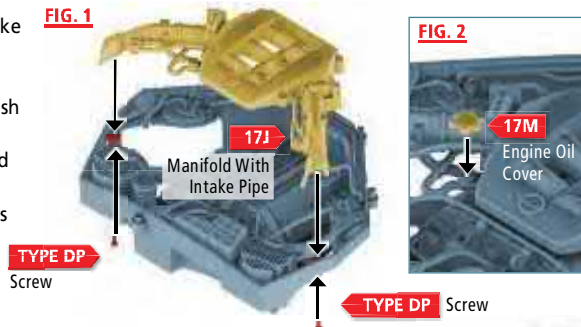

## Complete! The engine is completed

This completes the assembly of your NISSAN GT-R (R35) engine. Keep the completed Engine Room Bay safe, as it will be fitted into the front of the car later.



# THE REAR DIFFUSER

Now you will assemble some of the parts of your NISSAN GT-R (R35) model's Rear Diffuser.

## PARTS LOCATION

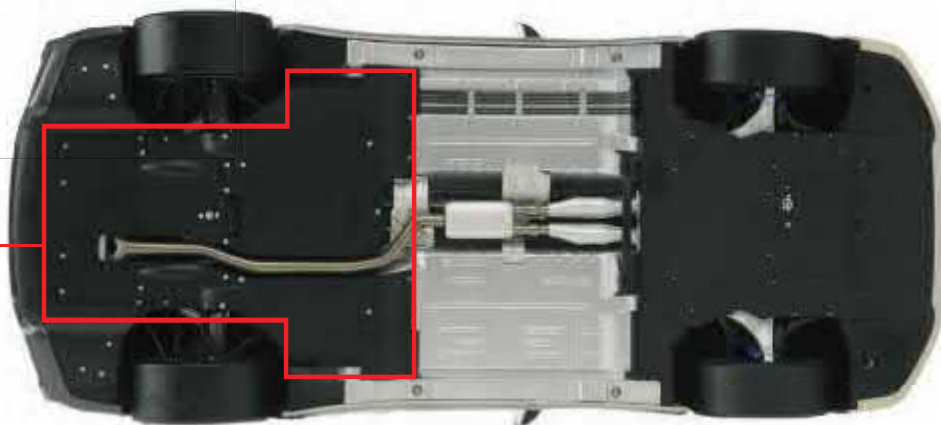

## PARTS LIST

### PART IDENTIFICATION LIST

PART No.	NAME	QUANTITY	MATERIAL
18A	Rear Diffuser Panel	1	ABS
18B	Rear Gearbox Oil Cover	1	ABS
18C	Rear Diffuser Middle Vent	1	ABS
18D	Rear Fog Light	1	ABS
18E	Left Rear Exhaust Trim	1	ABS
18F	Right Rear Exhaust Trim	1	ABS
Screws	Type BP 0.6 x 0.12" [1.5 x 3 mm]	3 [+2 spare]	Metal
Screws	Type HP 0.09 x 0.15" [2.3 x 4 mm]	13 [+6 spare]	Metal

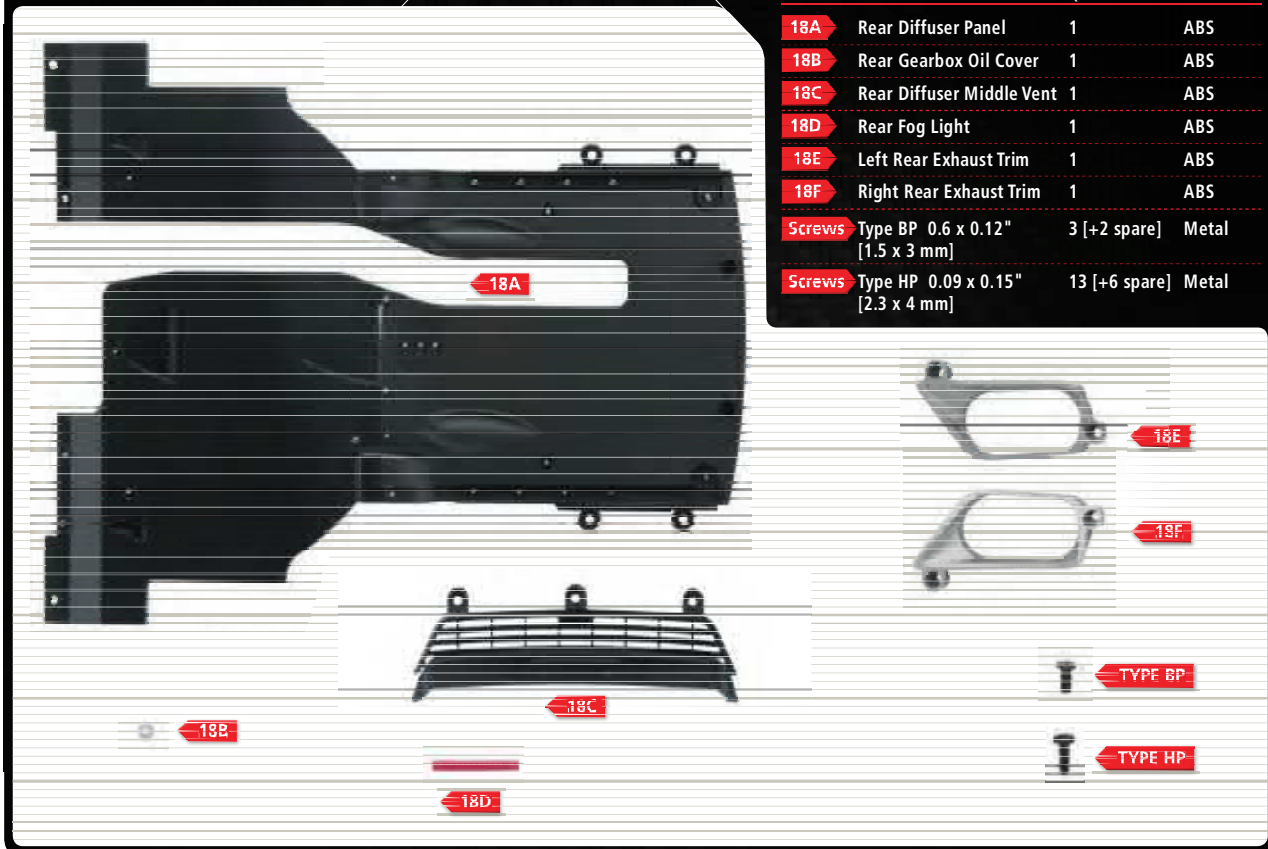

## STEP 01 Attach the Rear Diffuser Brake Light

Push the two small pegs on the back of the Rear Fog Light [18D] into the holes indicated on the Rear Diffuser Middle Vent [18C].

It will just push into place and there is no need for any screws.

Rear Fog Light

18D

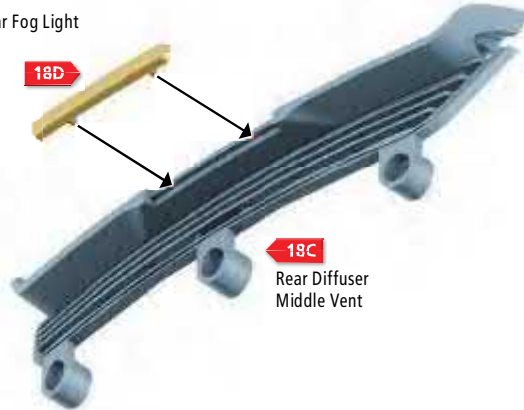

18C

Rear Diffuser Middle Vent

### COLOR KEY

- PART BEING FITTED
- PART BEING FITTED TO
- FIXINGS

### STEP 01 COMPLETE



## STEP 02 Attach the Rear Gearbox Oil Cover

Push the Rear Gearbox Oil Cover [18B] into the hole on the Rear Diffuser Panel [18A], as indicated in the illustration. Secure it from the other side with a TYPE BP screw.

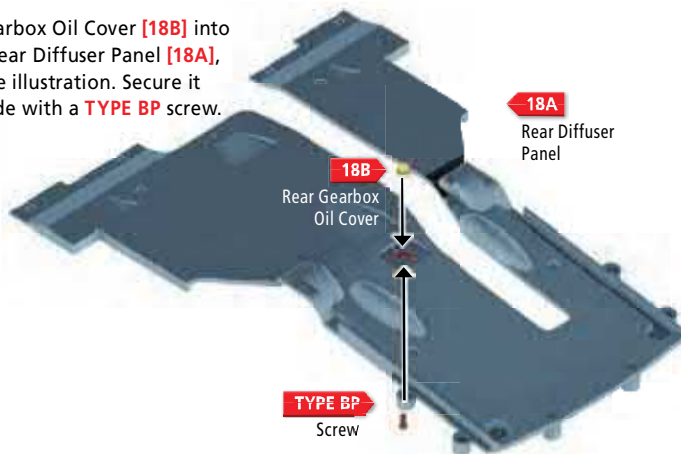

18A

Rear Diffuser Panel

18B

Rear Gearbox Oil Cover

TYPE BP  
Screw

### STEP 02 COMPLETE



## Complete!

### The Rear Diffuser

The rest of the parts that came with this issue cannot be fitted yet. They will be joined to parts that come in a future magazine.

### TIP!

Keep all unused parts and screws in a safe place.





# HOW TO BUILD

## THE REAR LEFT BRAKE DISC

In this magazine, you will fit together the parts of the Rear Left Brake Disc on your NISSAN GT-R (R35) model.

### PARTS LOCATION



### PARTS LIST

### PART IDENTIFICATION LIST

PART No.	NAME	QUANTITY	MATERIAL
19A	Brake Caliper	1	ZINC
19B	Brake Disc Plate	1	photoetch
19C	Brake Disc Plate Hub	1	ABS
19D	Brake Disc Base	1	ABS
Screws	Type BM 0.05 x 0.1" [1.5 x 3mm]	2 [+1 spare]	Metal
Screws	Type BP 0.05 x 0.1" [1.5 x 3mm]	2 [+1 spare]	Metal
	Washers	2 [+2 spare]	Plastic
	Wheel Cap	1	ABS

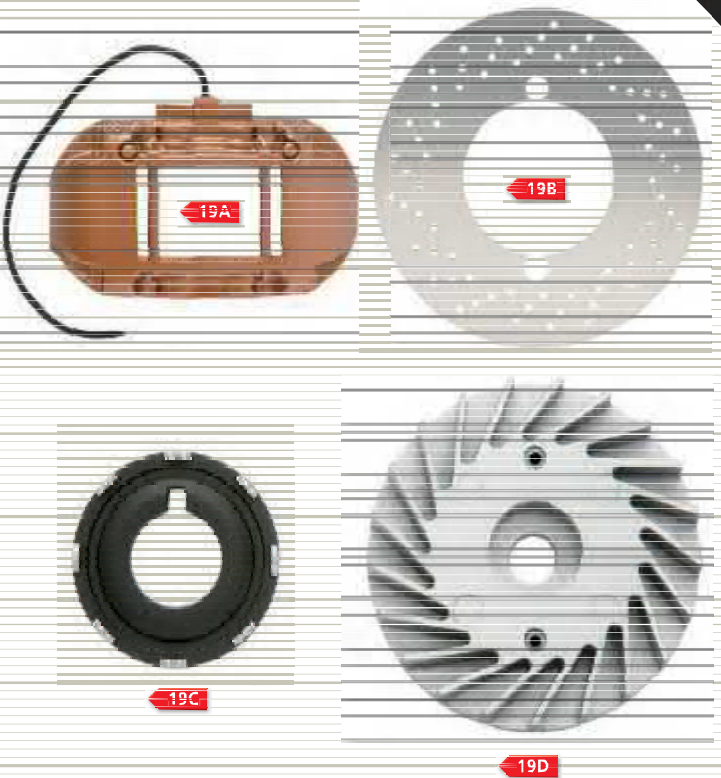

## STEP 01

### Apply the Brake Disc Plate to the Brake Disc Base

Hold the Brake Disc Base [19D] with the vanes facing up (see illustration) and place the Brake Disc Plate [19B] onto it, turning it until the screw holes line up. Do not screw the parts together yet.

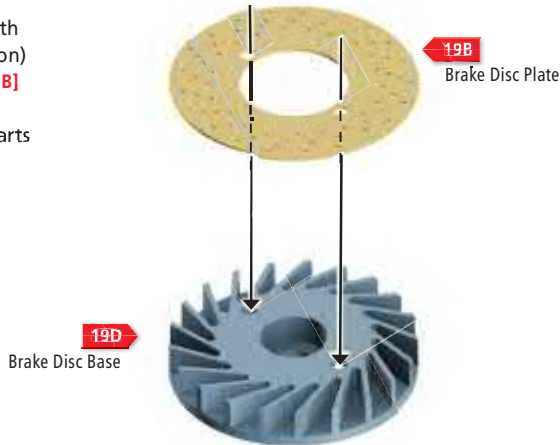

#### COLOR KEY

- PART BEING FITTED
- PART BEING FITTED TO
- FIXINGS

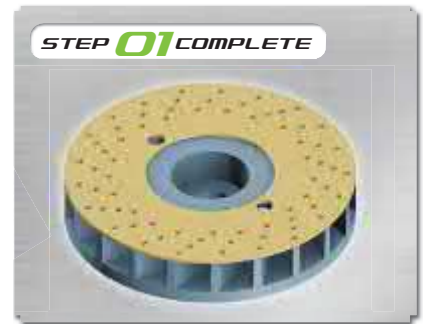

## STEP 02

### Add the Brake Disc Plate Hub

Take the Brake Disc Plate Hub [19C] and push its pegs through the holes on the combined Brake Disc Plate [19B] and Brake Disc Base [19D], holding it together with your fingers.

FROM STEP 1  
Combined parts

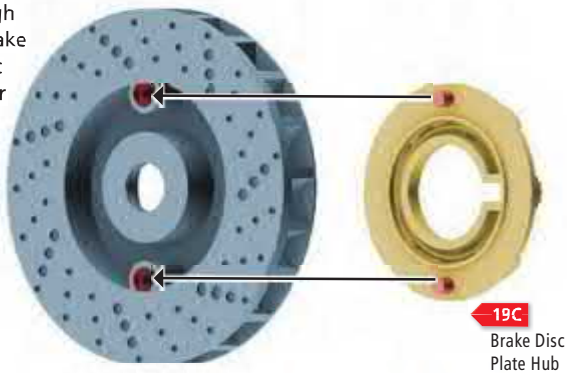

## STEP 03

### Fix the Brake Disc parts together

From the opposite side of the Brake Disc Plate Hub, use two TYPE BP screws to hold the parts together.

FROM STEP 2  
Combined parts

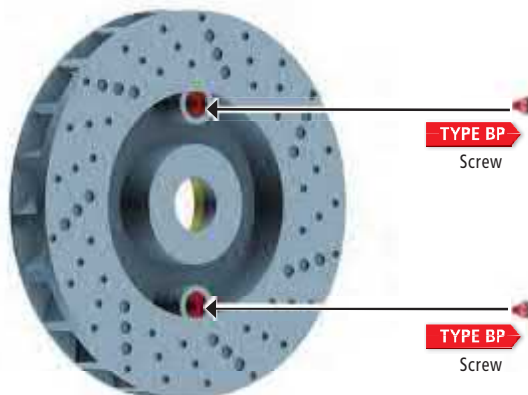

#### TIP!

This Brake Disc fits together in exactly the same way as the one with Magazine 2.

## STEP 04 Attach the Brake Caliper

Place the Brake Caliper [19A] onto the left Knuckle Base [11D] that you received with Magazine 4, as shown in the illustration, and secure it with two TYPE BM screws.

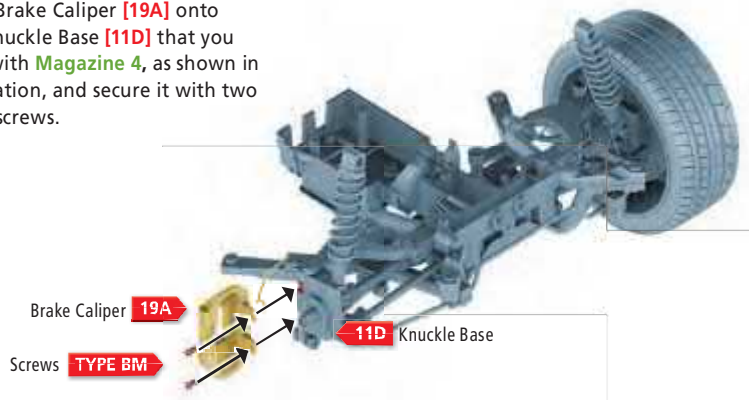

## STEP 05 Attach the combined Rear Left Brake Disc

First, place two Washers over the Knuckle Base [11D], followed by the combined Rear Left Brake Disc, as shown. These parts will be secured later, when the Rear Left Wheel and Tire are added.

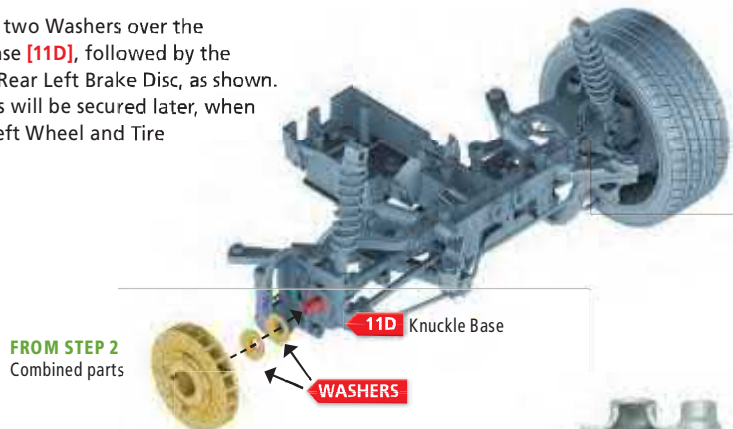

## Complete! The Rear Left Brake Disc

The Combined Rear Left Brake Disc will not remain loose on the Knuckle Base for long. It will be secured to the Rear Left Wheel and Tire when you follow the next set of instructions.

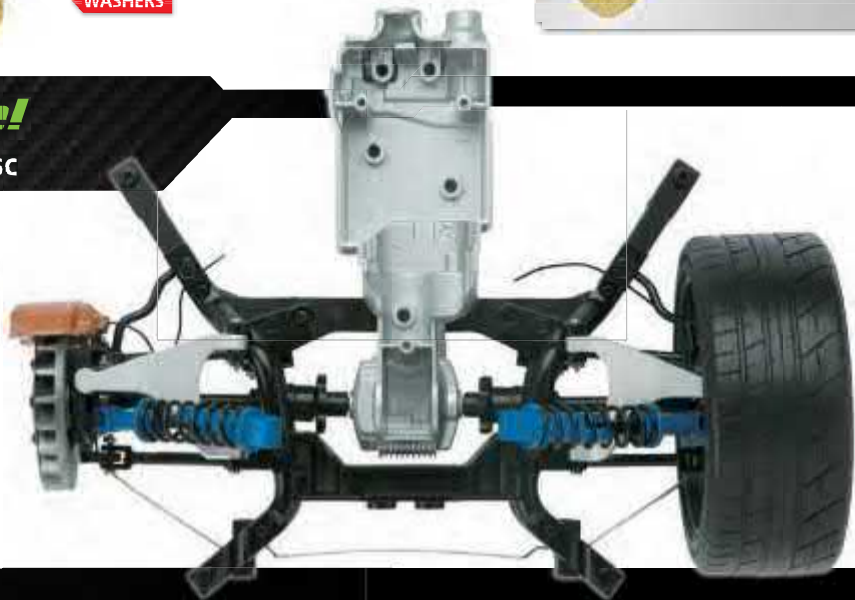

# REAR LEFT WHEEL AND TIRE

Now you will attach the Left Wheel and Tire to the Rear Left Suspension that you have already built.

**PARTS LOCATION**



## PARTS LIST

### PART IDENTIFICATION LIST

PART No.	NAME	QUANTITY	MATERIAL
20A	Wheel	1	ZINC
20B	Wheel Cap	1	ABS
20C	Rear Tire	1	PVC
Screws	Type CM 0.1 x 0.2" [2.6 x 6mm]	1 [+1spare]	Metal



20A



20B



20C



TYPE CM



# HOW TO BUILD

## STEP 01 Place the Rear Tire in a container of warm water

The Rear Tire [20C] needs to fit tightly on to the Wheel and it can be difficult to push it on. To make it easier, place the Tire in a container of warm water and leave it to soak for approximately 5 minutes.

**COLOR KEY**  
■ PART BEING FITTED  
■ PART BEING FITTED TO  
■ FIXINGS



### TIP!

Please be careful to avoid burning yourself when removing the tire from the warm water.

## STEP 02 Fit the Rear Tire to the Rear Left Wheel

Now, take the Rear Tire [20C], out of the water – it should be softer and easier to manipulate – and ease it slowly over the Rear Left Wheel [20A]. Make sure the rough side of the tread pattern (see illustration) faces the outside of the Wheel.



## STEP 03

### Add the combined Rear Left Wheel and Tire to the Left Knuckle Base

Slide the center hole of the combined Rear Left Wheel and Tire [20A/C] onto the peg of the Knuckle Base [11D], as indicated in the illustration, and secure it with a TYPE CM screw. Now, thread the Brake Caliper Cable through the small hole between the Upper Mount and the Rear Cross Member – see FIG.2.

FROM STEP 2  
Combined parts

TYPE CM  
Screw

FIG. 1

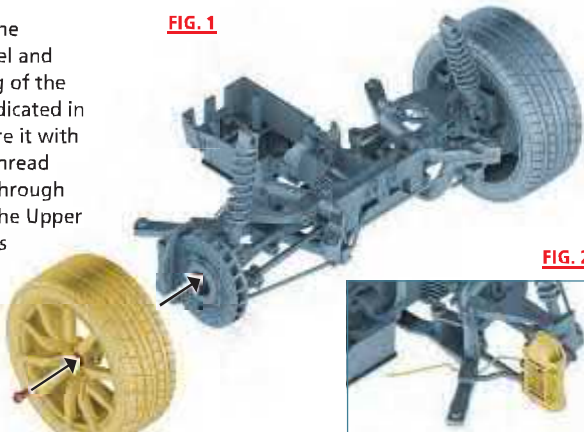

FIG. 2



STEP 03 COMPLETE



## STEP 04

### Add the Wheel Cap

Finally, push the Wheel Cap [20B] into the center hole on the Rear Left Wheel [20A], as shown in the illustration. It will just click into place and there is no need for any screws.

Wheel Cap [20B]

[20A]

Rear Left Wheel



STEP 04 COMPLETE



## Complete!!

### The Rear Left Wheel

This completes the Rear Suspension, Rear Brakes and Rear Wheels. Keep this completed section of your model somewhere safe, as it will be joined to parts that come later.



## How to adjust the Rear Right Wheel

If you feel that the Rear Right Wheel you built in **Magazine 1** is more shaky than the Rear Left Wheel, you can add a Washer to make it more secure.

### STEP 01 Remove the Right Rear Wheel

#### TIP!

There is no need to follow these steps if you think the Rear Right Wheel is already secure enough.

First, remove the Wheel Cap [02C] with a thin, flat-blade screwdriver or similar tool. Now, unscrew the TYPE CM screw and pull off the Wheel and then the combined Brake Disc.

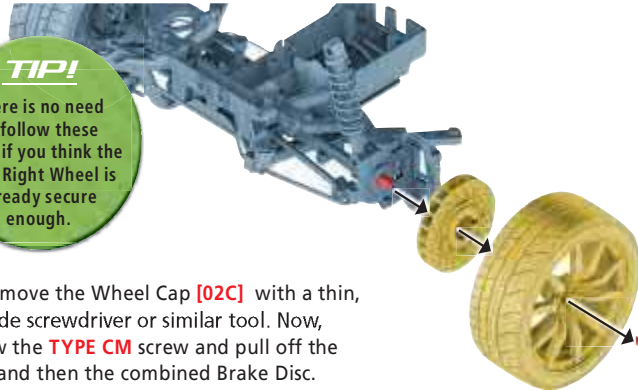

### STEP 02 Add the Washer

Take one of the Washers you received and slide it onto the Knuckle Base [04D], as indicated in the illustration. Push the combined Brake Disc back onto the Knuckle Base over the Washer.

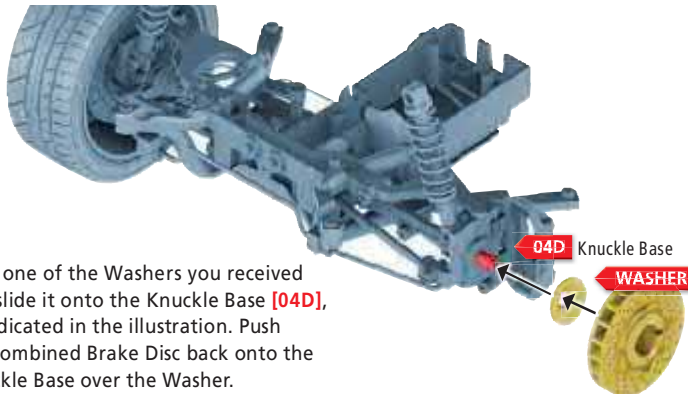

### STEP 03 Reattach the Rear Right Wheel

#### TIP!

If you damaged the Wheel Cap when removing it, use the replacement Wheel Cap supplied.

Reattach the Wheel by securing it with a TYPE CM screw. Finally, push the Wheel Cap back on.

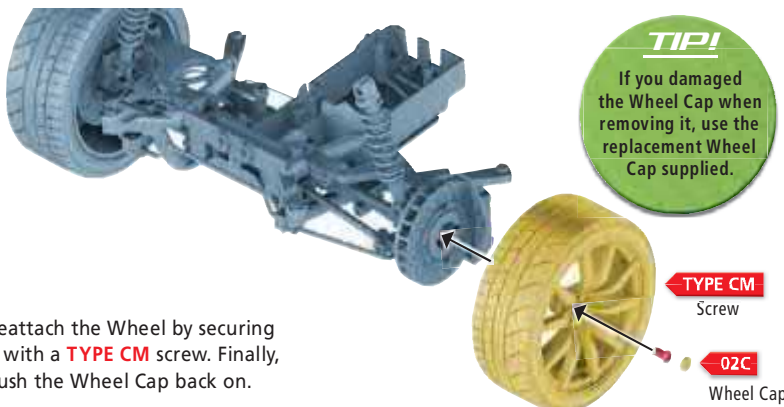

# GEAR SHIFT BASE PARTS

Now you will fit the Gear Lever and the Handbrake to the Gear Shift Base, which is located in the interior of your model NISSAN GT-R (R35) between the front seats.

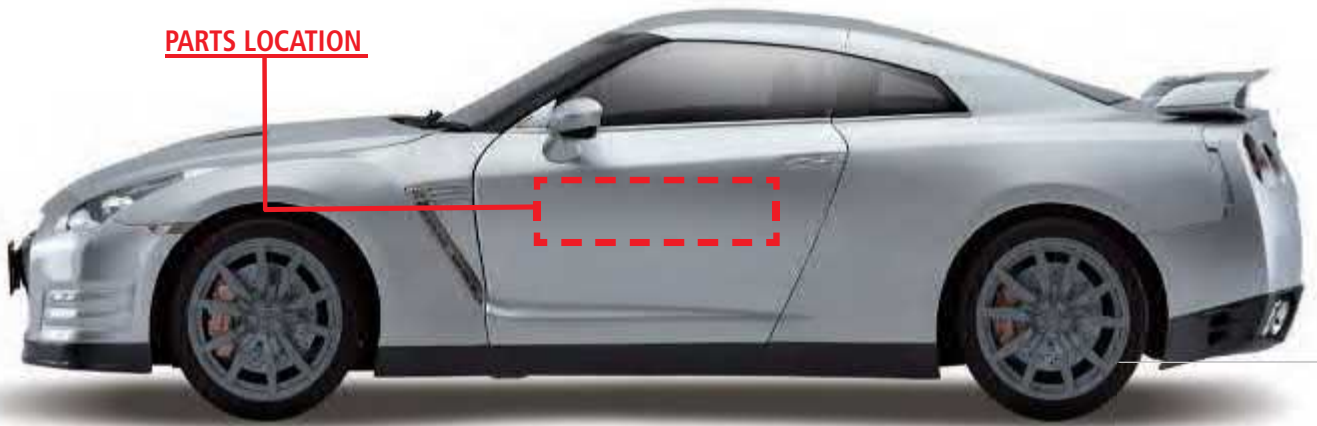

## PARTS LIST

### PART IDENTIFICATION LIST

PART No.	NAME	QUANTITY	MATERIAL
21A	Gear Lever	1	ABS
21B	Gear Shift Base	1	ABS
21C	Handbrake	1	ABS
21D	Rear Console Speaker	1	ABS
Screws	Type GP 0.08 x 0.16" [2 x 4mm]	4 [+6 spare]	Metal



21A



TYPE GP



21B



21C



21D

## STEP 01 Attach the Gear Lever

Push the Gear Lever [21A] into the hole indicated on the Gear Shift Base [21B] in FIG.1. Note the position of the notch on the Gear Lever.

FIG. 1

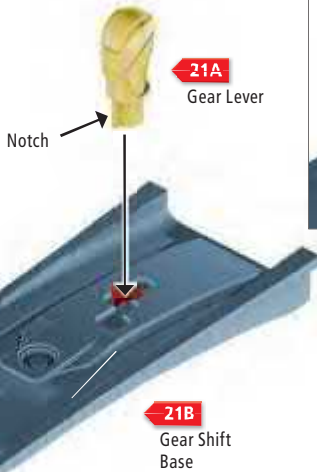

Turn the Gear Shift Base [21B] over, making sure you hold the Gear Lever [21A] in place. Now, place a TYPE GP screw in the hole indicated in the illustration.

### COLOR KEY

- PART BEING FITTED
- PART BEING FITTED TO
- FIXINGS



## STEP 02 Attach the Handbrake

Push the peg on the bottom of the Handbrake [21C] into the hole on the Gear Shift Base [21B], indicated in the FIG.1 illustration.

FIG. 1

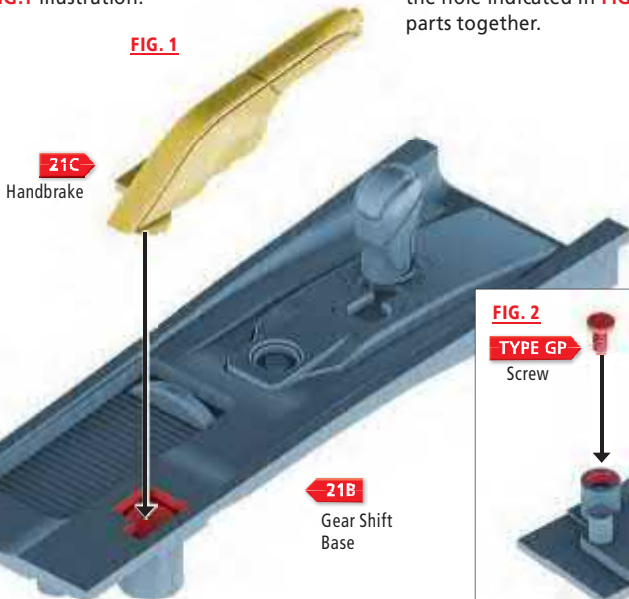

Turn the Gear Shift Base [21B] over, making sure that you hold the Handbrake in place. Now, push a TYPE GP screw into the hole indicated in FIG.2 and secure the parts together.

FIG. 2



## *Complete!*

### You have completed the Gear Shift Base

Don't worry about the Rear Console Speaker for now, as this will be attached later.

#### *TIP!*

Keep all unused parts and screws in a safe place.



## YOUR NISSAN GT-R (R35) SCALE MODEL INTERIOR

When completed, your NISSAN GT-R (R35) scale model's interior will be an exact replica of the 2011 Japanese production car. This is how the interior should look once you have carefully assembled all the parts.



## THE CENTER CONSOLE

Now you will fit the Arm Rest and Cup Holder to the Center Console of your NISSAN GT-R (R35). You will also fit the parts that you assembled in the previous pages to the Center Console.

### PARTS LOCATION

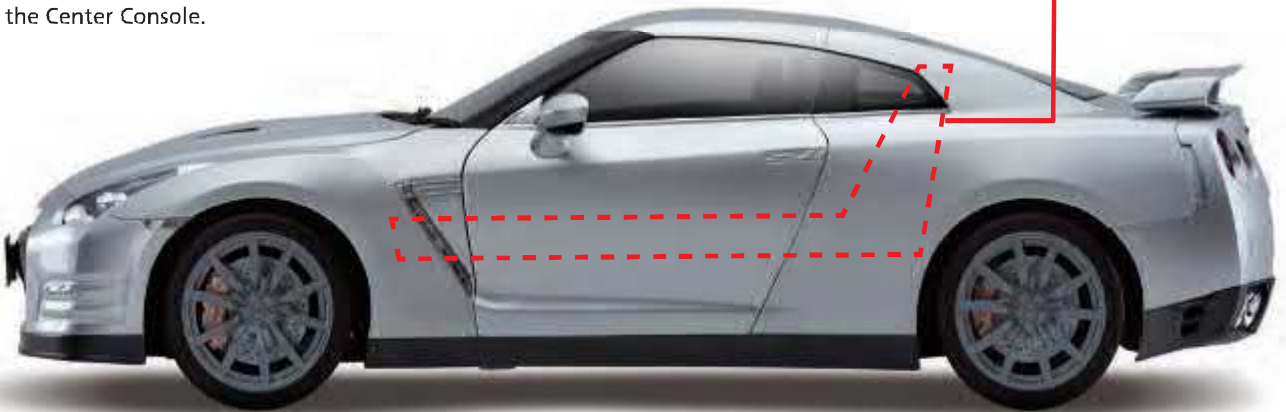

### PARTS LIST

#### PART IDENTIFICATION LIST

PART No.	NAME	QUANTITY	MATERIAL
22A	Center Console	1	ABS
22B	Console Arm Rest	1	ABS
22C	Console Arm Rest Part	1	ABS
22D	Rear Console Cup Holder	1	ABS
Screws	Type GP 0.08" x 0.16" [2 x 4mm]	10 [+4 spare]	Metal
Screws	Type DM 0.08" x 0.12" [2 x 3mm]	2 [+1 spare]	Metal

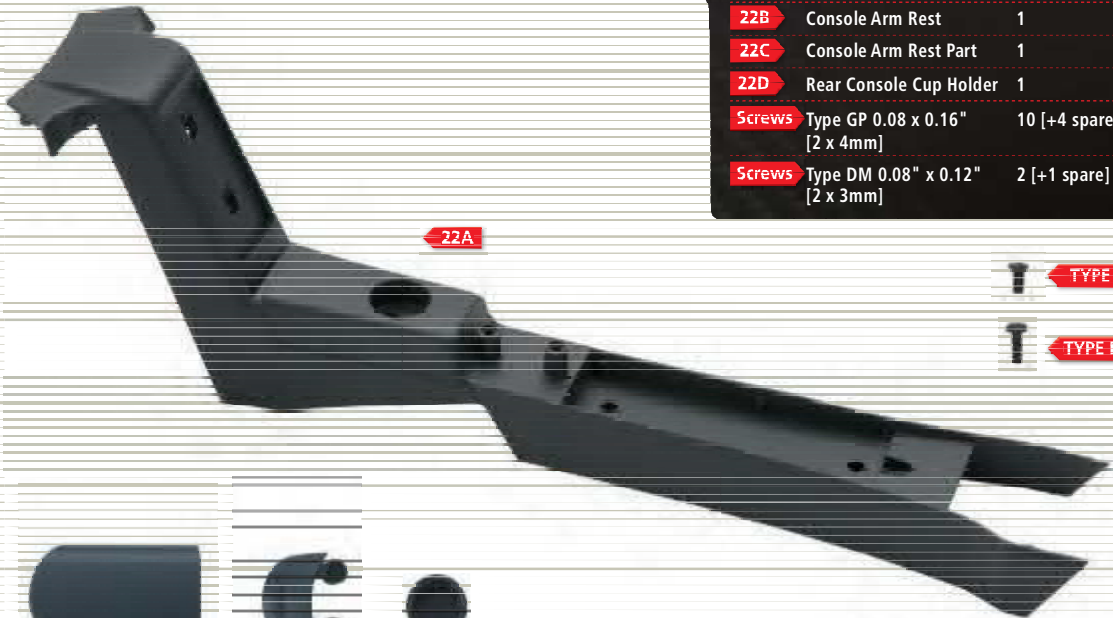

22A

TYPE GP

TYPE DM

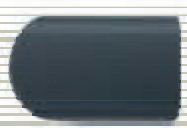

22B



22C



22D

## STEP 01

### Attach the Gear Shift Base

Slot the Gear Shift Base [21B] that you built earlier onto the Center Console [22A], as indicated in the illustration. Secure it from underneath with two **TYPE GP** screws.

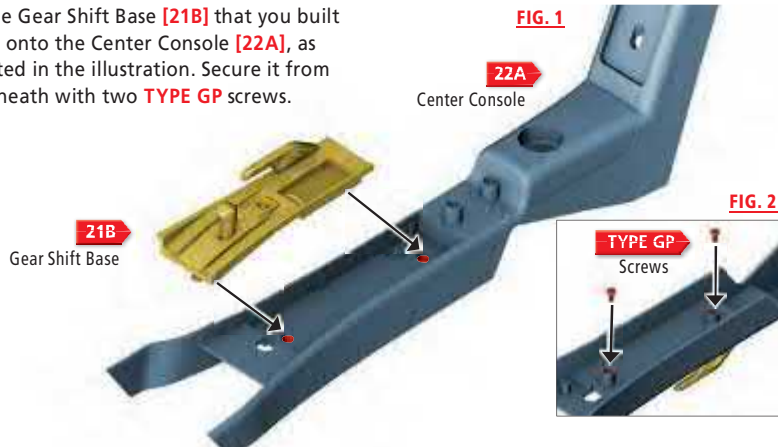

#### COLOR KEY

- PART BEING FITTED
- PART BEING FITTED TO
- FIXINGS



## STEP 02

### Attach the Rear Console Speaker

Slot the Rear Console Speaker [21D] onto the Center Console [22A] as indicated in **FIG. 1**. Secure it in place with two **TYPE DM** screws from the back of the Center Console – see **FIG. 2**.



## STEP 03

### Attach the Rear Console Cup Holder

Slot the Rear Console Cup Holder [22D] into the hole on the Center Console [22A], as indicated in the illustration. Secure it from underneath with a **TYPE GP** screw – see **FIG. 2**.





## STEP 04 Assemble the Console Arm Rest

Slot the pegs on the Console Arm Rest Part [22C] over the holes indicated in the Console Arm Rest [22B]. Secure the parts together with two **TYPE GP** screws – see FIG.2.

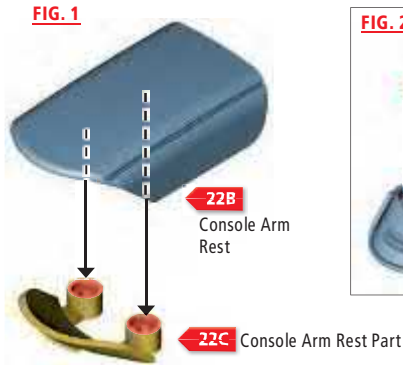

**COLOR KEY**

- PART BEING FITTED
- PART BEING FITTED TO
- FIXINGS



## STEP 05 Attach the Rear Gearbox Oil Cover

Slot the Console Arm Rest [22B] onto the pegs of the Center Console [22A], as indicated in the illustration. Secure the parts together from underneath with two **TYPE GP** screws – see FIG.2.

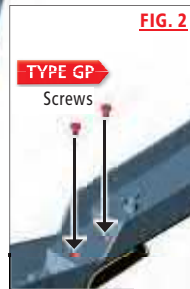
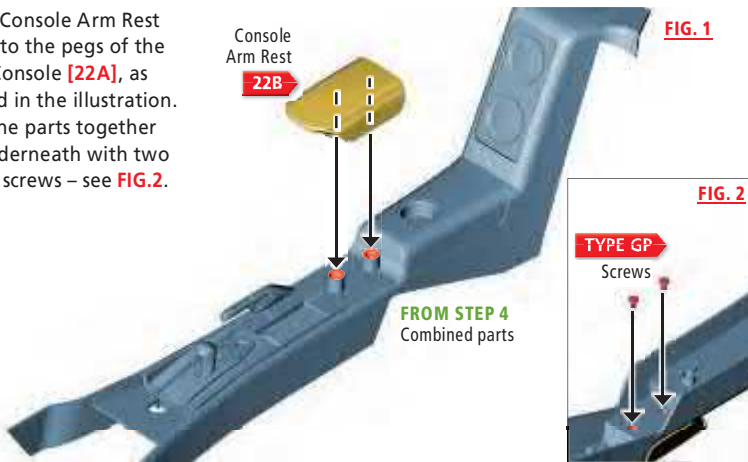

## Complete!

The Center Console is completed

In the next magazine, you will attach this completed Center Console to the Interior Base.

**TIP!**

Keep your completed Center Console in a safe place.





# HOW TO BUILD

## INTERIOR BASE

In this section, you will attach the combined Center Console, which you built in [Magazine 6](#), to your NISSAN GT-R (R35) model's Interior Base.

### PARTS LOCATION

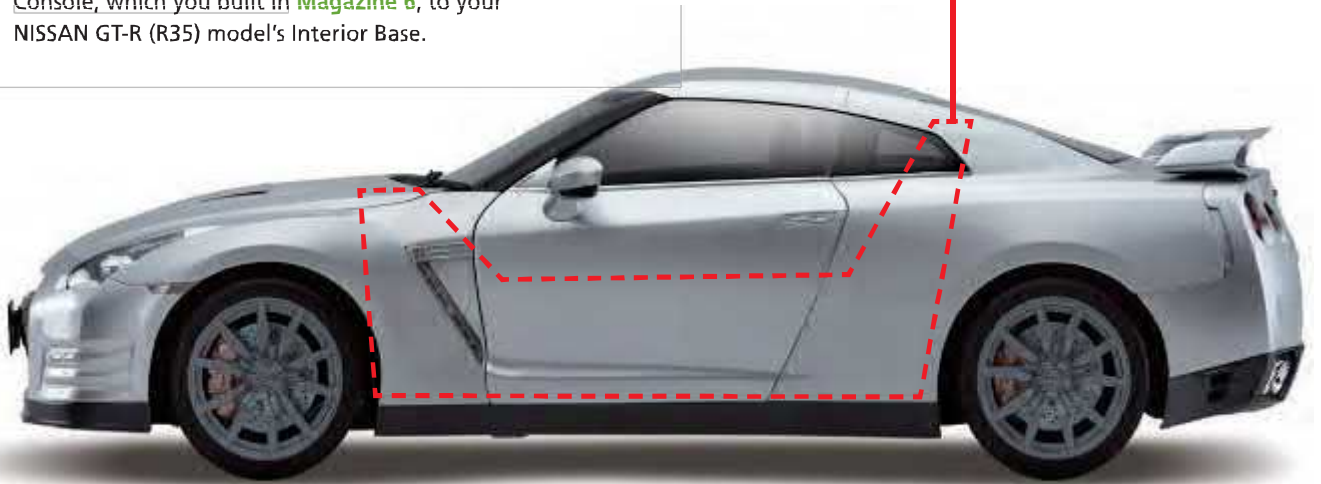

## PARTS LIST

### PART IDENTIFICATION LIST

PART No.	NAME	QUANTITY	MATERIAL
23A	Interior Base	1	ABS
Screws	Type CP 0.1 x 0.2" [2.6 x 6mm]	6 [+2 spares]	Metal

### TIP!

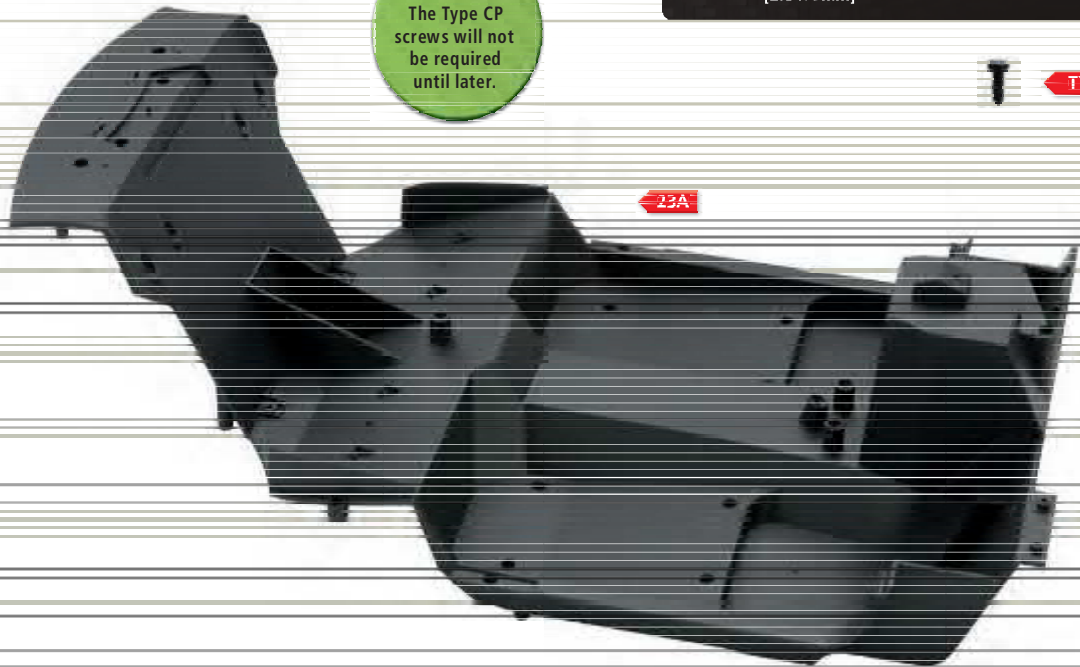

The Type CP screws will not be required until later.



# STEP 01

## Attach the Center Console

### COLOR KEY

-  PART BEING FITTED
-  PART BEING FITTED TO
-  FIXINGS

Take the combined Center Console [22A] that you built in Magazine 6 and slot it into the Interior Base [23A], as indicated in FIG.1.

Now, turn the Interior Base over and secure the Center Console with 5 TYPE GP screws that also came with Magazine 6 – see FIG.2.

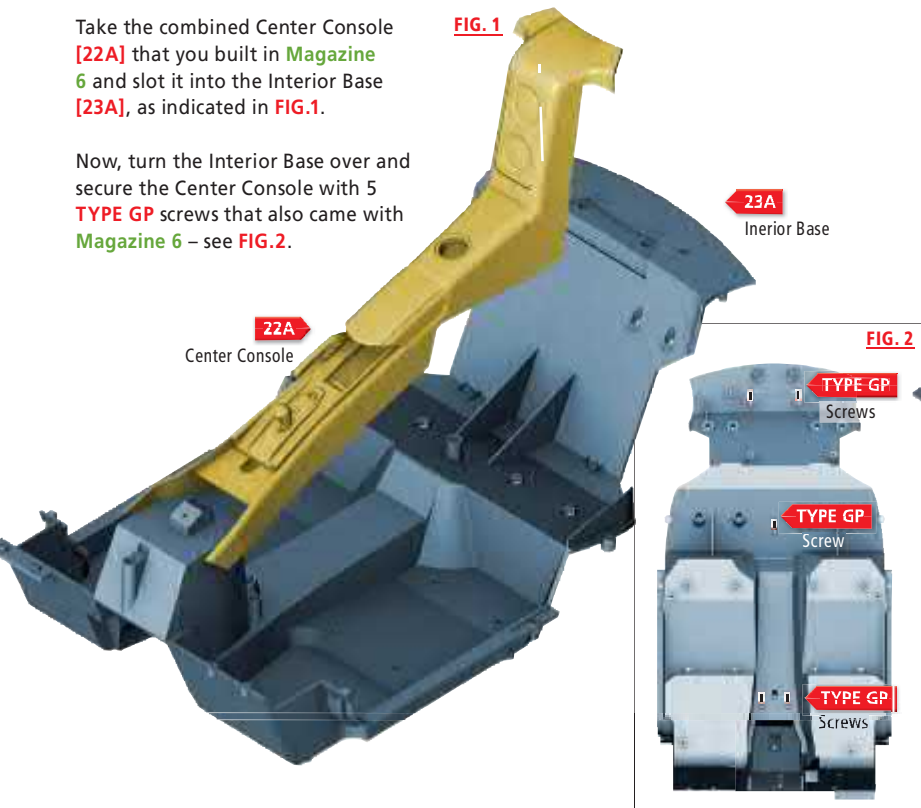

**TIP!**  
Slide in the front section of the Center Console first.

## Complete!

Center Console is attached to the Interior Base

More parts will be fitted to the Interior Base over the next few pages.



## THE REAR LEFT SEAT

Now you will assemble the Rear Left Safety Belt parts and attach the Rear Left Seat to the Interior Base.

### PARTS LOCATION

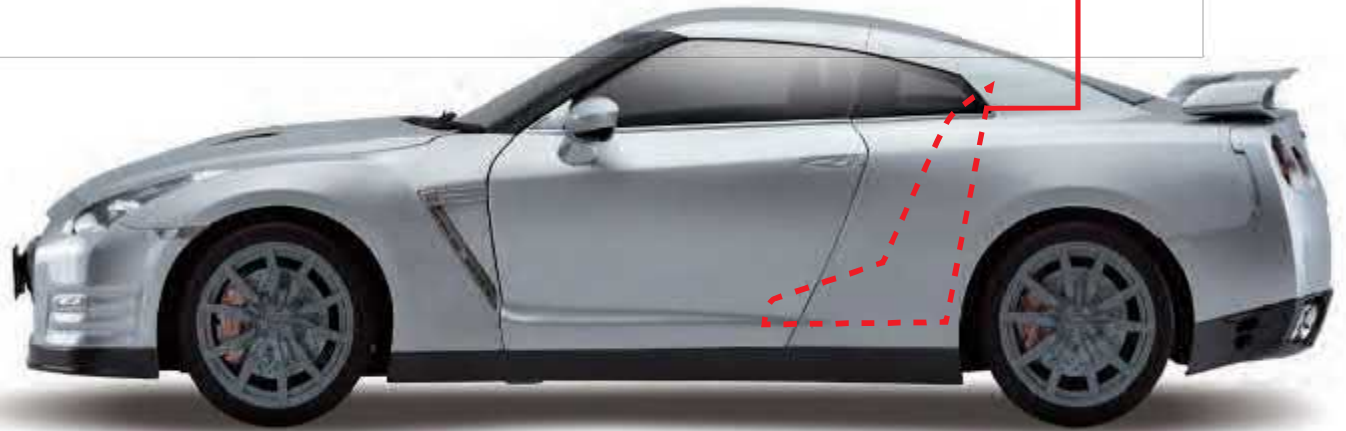

### PARTS LIST



#### TIP!

The Seat Belt Pins have either '2' or '4' written on the back, so that you can tell them apart.

### PART IDENTIFICATION LIST

PART No.	NAME	QUANTITY	MATERIAL
24A	Rear Left Seat	1	ABS
24B	Seat Belt Buckle	1	ABS
24C	Safety Belt	1	Nylon Cloth
24D	Seat Belt Clip	1	ABS
24E	Seat Belt Pin 2	1	ABS
24F	Seat Belt Pin 4	1	ABS
Screws	Type GP 0.08 x 0.16"	4 [+2 spares]	Metal [2 x 4mm]
Screws	Type HM 0.09 x 0.15"	2 [+2 spares]	Metal [2.3 x 4mm]



24B



24D



24E



24F

24C



TYPE GP



TYPE HM

## STEP 01

### Attach the Seat Belt Buckle

Push the peg on the bottom of the Seat Belt Buckle [24B] into the hole on the Rear Left Seat [24A], as indicated in the illustration. Make sure that you put it in the correct way. It will hold in place without the need for any screws.



#### COLOR KEY

- PART BEING FITTED
- PART BEING FITTED TO
- FIXINGS



## STEP 02

### Thread the Safety Belt through Seat Belt Pin 2

Thread the end of the Safety Belt [24C] in and out of the slots of Seat Belt Pin 2 [24E], as indicated in the illustration.

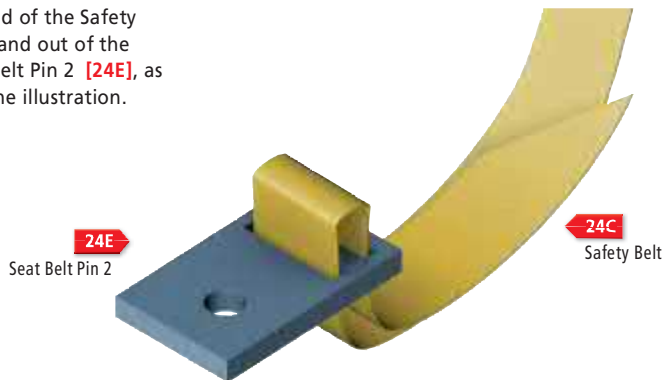

## STEP 03

### Attach Seat Belt Pin 2 to the Interior Base

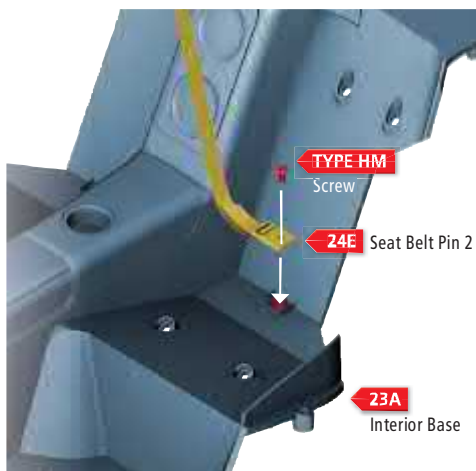

Match up the peg and hole on Seat Belt Pin 2 [24E] with the relevant slot on the Interior Base [23A], as indicated in the illustration. You will notice that it is marked with a '2', indicating that Seat Belt Pin 2 goes here. Secure it in place from above with a TYPE HM screw.



## STEP 04 Thread the Safety Belt through the Rear Left Seat

Thread the Safety Belt [24C] through the hole in the Rear Left Seat [24A], as indicated in the illustration, and then slot the four pegs on the back of the Seat into the holes on the Interior Base.



## STEP 05 Secure the Rear Left Seat

Holding the Rear Left Seat firmly in place, turn the Interior Base [23A] over and secure the Seat in place with 4 TYPE GP screws in the holes indicated in the illustration.

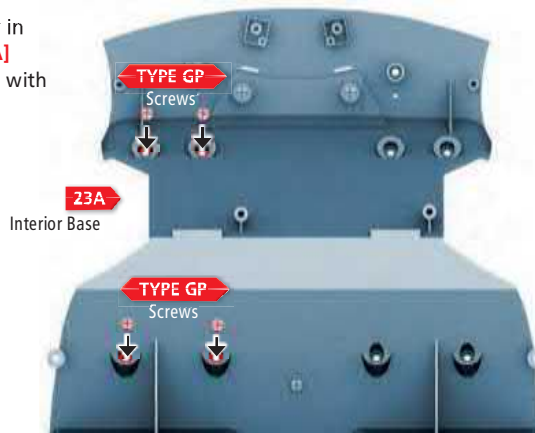

## STEP 06 Attach the Seat Belt Clip to the Safety Belt

Thread the Seat Belt Clip [24D] onto the Safety Belt [24C] and then push the Safety Belt through the hole at the back of the Interior Base [23A] – see completed illustration, right.



## STEP 07 Secure the Safety Belt

Thread the Safety Belt [24C] through the slots in Seat Belt Pin 4 [24F], as shown in FIG.1.

FIG. 1

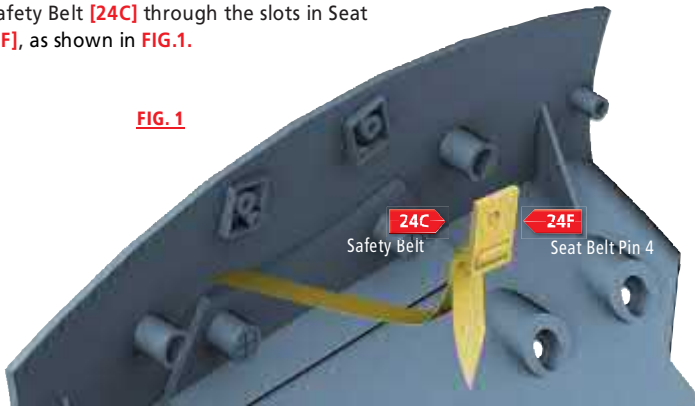

Now, match up the peg and hole on Seat Belt Pin 4 [24F] with the holes on the Interior Base, as shown in FIG.2. Secure it in place with a TYPE HM screw. You will notice that the square raised area on the Interior Base is marked with a '4' indicating that Seat Belt Pin 4 goes here.

FIG. 2

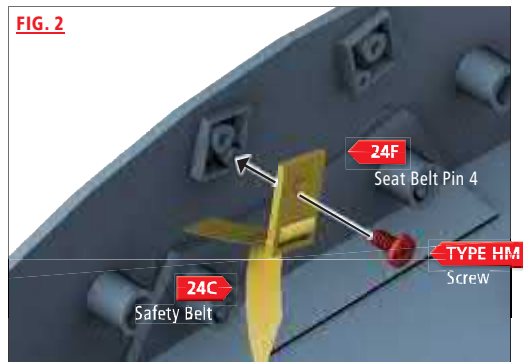

## STEP 07 COMPLETE



## Complete!

### Rear Left Seat attached to the Interior Base

In the next section, you will fit the Rear Right Seat to the Interior Base.

#### TIP!

The Safety Belt mechanism does not function, so do not try and fit the clip into the Buckle.



#### TIP!

Adjust the length of the Safety Belt so that it is not too loose at the front of the Seat, as shown here.



## THE REAR RIGHT SEAT

Now you will assemble the Rear Right Safety Belt parts and attach the Rear Right Seat to the Interior Base.

### PARTS LOCATION

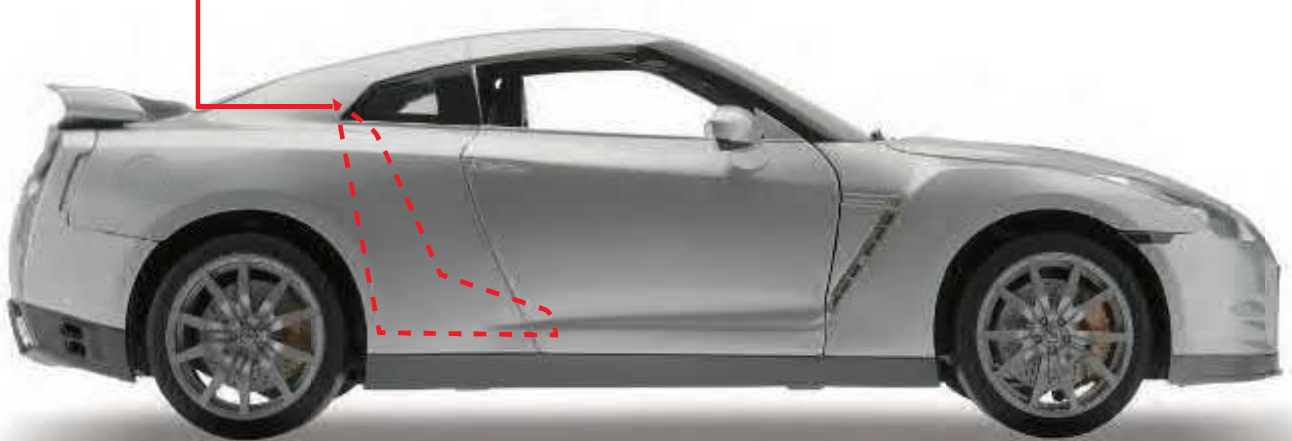

### PARTS LIST



25A



25B



25D



25E



25F



TYPE GP



TYPE HM

25C

### PART IDENTIFICATION LIST

PART No.	NAME	QUANTITY	MATERIAL
25A	Rear Right Seat	1	ABS
25B	Seat Belt Buckle	1	ABS
25C	Safety Belt	1	Nylon Cloth
25D	Seat Belt Clip	1	ABS
25E	Seat Belt Pin 1	1	ABS
25F	Seat Belt Pin 3	1	ABS
Screws	Type GP 0.08 x 0.16" [2 x 4mm]	4 [+2 spare]	Metal
Screws	Type HM 0.09 x 0.15" [2.3 x 4mm]	2 [+2 spare]	Metal

## STEP 01

### Attach the Seat Belt Buckle

Push the peg on the bottom of the Seat Belt Buckle [25B] into the hole on the Rear Right Seat [25A], as indicated in the illustration. Make sure that you put it in the correct way. It will hold in place without the need for any screws.



#### COLOR KEY

- PART BEING FITTED
- PART BEING FITTED TO
- FIXINGS

STEP 01 COMPLETE

## STEP 02

### Thread the Safety Belt through Seat Belt Pin 1

Thread the end of the Safety Belt [25C] in and out of the slots of Seat Belt Pin 1 [25E], as indicated in the illustration.

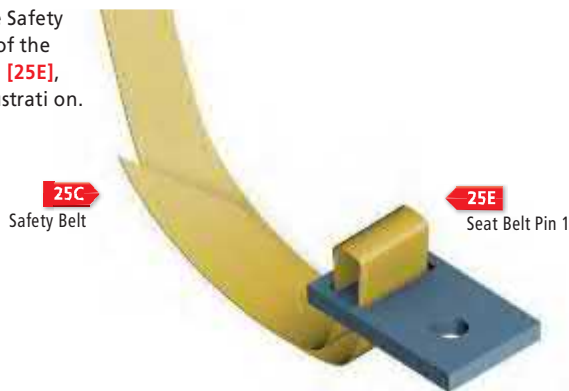

STEP 02 COMPLETE

## STEP 03

### Attach Seat Belt Pin 1 to the Interior Base

Match up the peg and hole on Seat Belt Pin 1 [25E] with the relevant slot on the Interior Base [23A], as indicated in the illustration. You will notice that it is marked with a '1', indicating that Seat Belt Pin 1 goes here. Secure it in place from above with a TYPE HM screw.

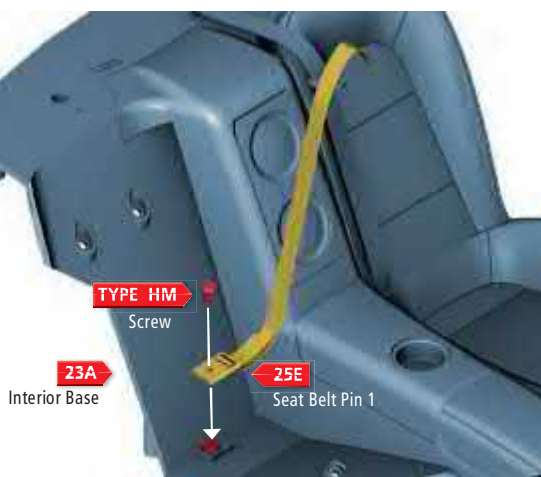

STEP 03 COMPLETE

## STEP 04 Thread the Safety Belt through the Rear Right Seat



Thread the Safety Belt [25C] through the hole in the Rear Right Seat [25A], as indicated in the illustration, and then slot the four pegs on the back of the Seat into the holes on the Interior Base.



## STEP 05 Secure the Rear Right Seat

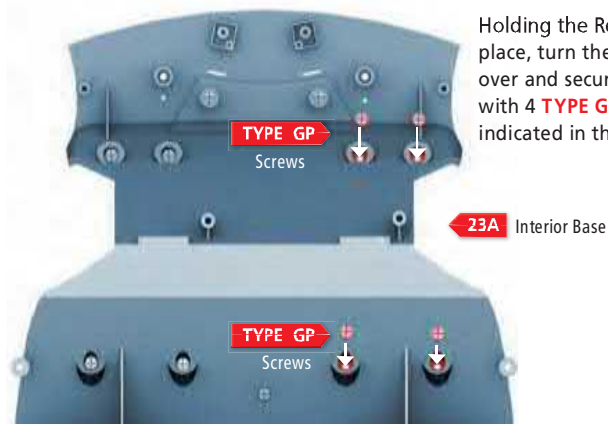

Holding the Rear Right Seat firmly in place, turn the Interior Base [23A] over and secure the Seat in place with 4 TYPE GP screws in the holes indicated in the illustration.



## STEP 06 Attach the Seat Belt Clip to the Safety Belt

Thread the Seat Belt Clip [25D] onto the Safety Belt [25C] and then push the Safety Belt through the hole at the back of the Interior Base, as shown in the completed illustration, far right.



## STEP 07

### Secure the Safety Belt

Thread the Safety Belt [25C] through the slots in Seat Belt Pin 3 [25F], as shown in FIG.1.

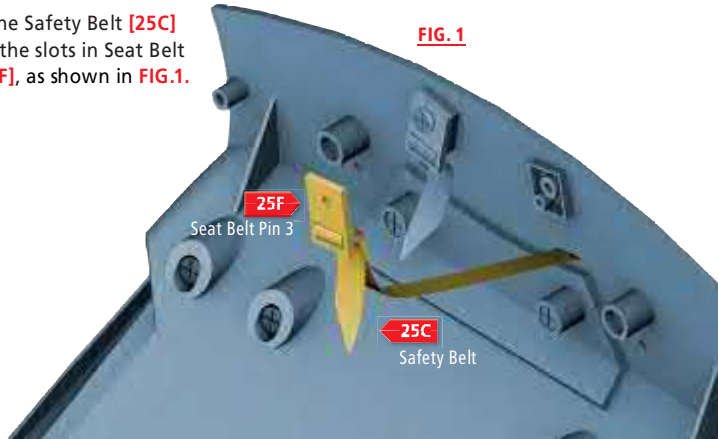
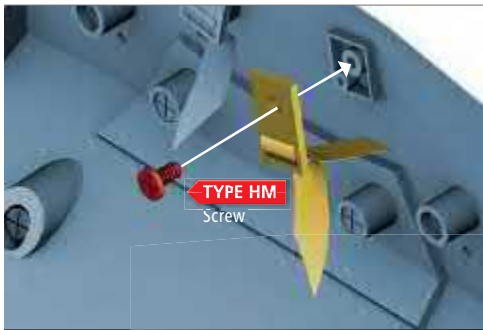

FIG. 2



Now, match up the peg and hole on Seat Belt Pin 3 [25F] with the holes on the Interior Base, as shown in FIG.2. Secure it in place with a TYPE HM screw. You will notice the square raised area on the Interior Base is marked with a '3' indicating that Seat Belt Pin 3 goes here.

## Complete!

### Rear Right Seat attached to the Interior Base

In the next section, you will fit the Gas and Brake Pedals to the Interior Base.

#### TIP!

The Safety Belt mechanism does not function, so do not try and fit the clip into the Buckle.

#### TIP!

Adjust the length of the Safety Belt so that it is not too loose at the front of the Seat, as shown here.

## THE FOOT PEDALS

Now you will fit the Gas and Brake Pedals, plus the Foot Rest, to the Interior Base of your NISSAN GT-R (R35) model.

### PARTS LOCATION

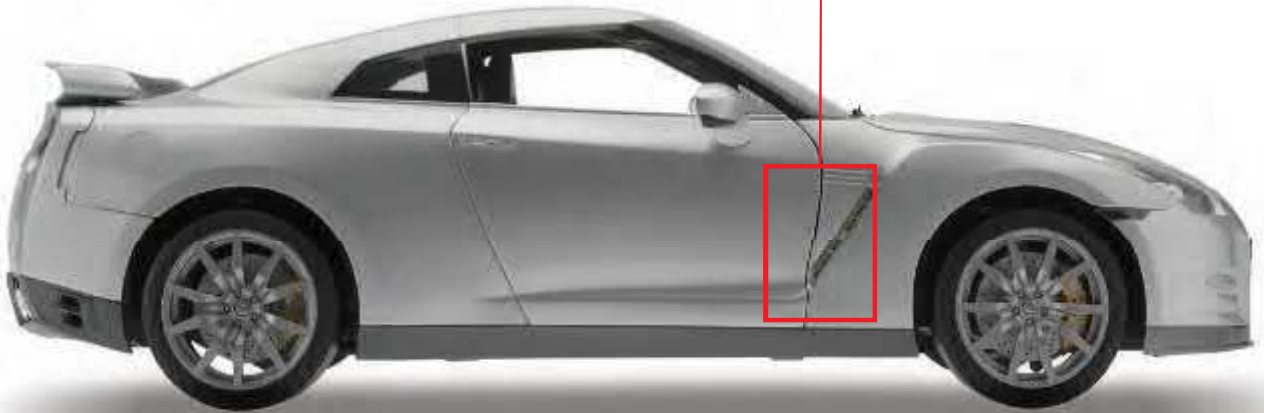

### PARTS LIST

#### PART IDENTIFICATION LIST

PART No.	NAME	QUANTITY	MATERIAL
26A	Gas Pedal Assembly	1	ABS
26B	Brake Pedal	1	ABS
26C	Foot Rest	1	ABS
Screws	Type GP 0.08 x 0.16" [2 x 4mm]	2 [+1 spare]	Metal
Screws	Type JP 0.06 x 0.2" [1.7 x 6mm]	1 [+1 spare]	Metal

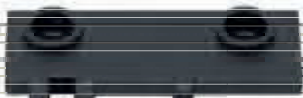

26A



26B



26C



TYPE GP



TYPE JP

## STEP 01

### Attach the Brake Pedal

Position the hole at the end of the Brake Pedal [26B] between the holes on the Gas Pedal Assembly [26A], as shown in the illustration. Now, screw in a TYPE JP screw from the side through the holes to secure the Brake Pedal in place.

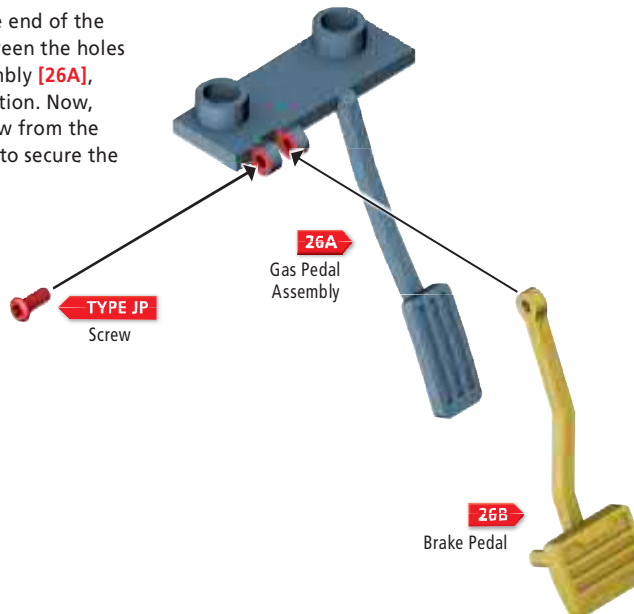

#### COLOR KEY

- PART BEING FITTED
- PART BEING FITTED TO
- FIXINGS

#### STEP 01 COMPLETE



## STEP 02

### Attach the Pedals to the Interior Base

Place the holes on the Gas Pedal Assembly [26A] over the two pegs on the Interior Base [23A], as indicated in the illustration. Use two TYPE GP screws from above to secure the parts together.

Make sure the peg on the back of the Brake Pedal [26B] goes into the hole in the footwell of the Interior Base – see FIG. 2.

FIG. 1

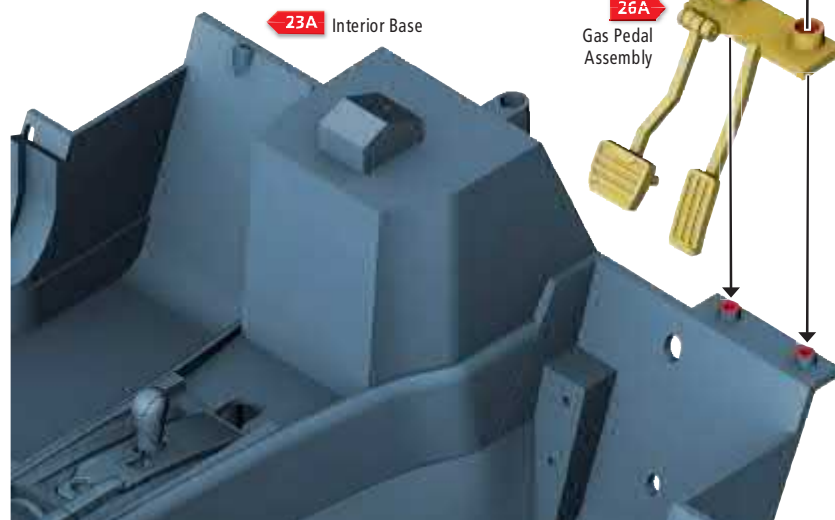
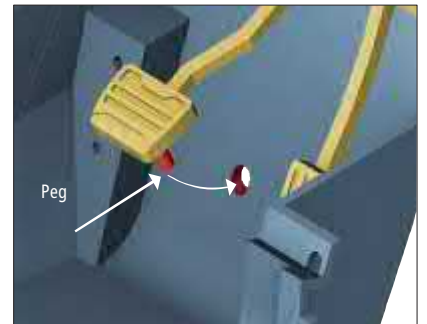

FIG. 2



#### STEP 02 COMPLETE



# HOW TO BUILD

## STEP 03 Attach the Foot Rest to the Interior Base

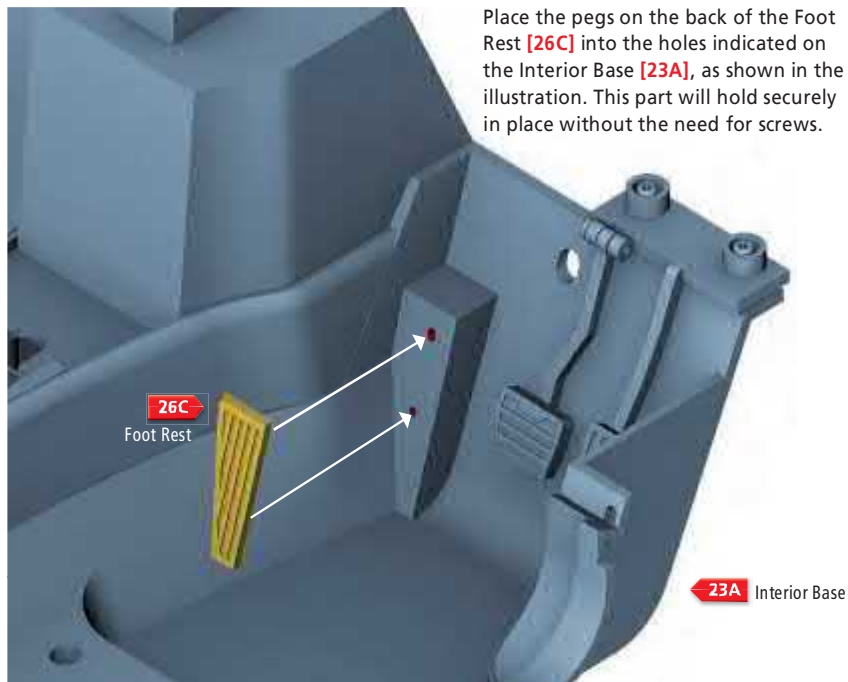

## Complete!

### Completion of the Foot Pedals

The Foot Pedals of your NISSAN GT-R (R35) model are now fully installed.

#### TIP!

The Brake Pedal will eventually be used to operate the Brake Lights on your model.





# HOW TO BUILD

## THE FRONT LEFT SEAT

In this section, you will assemble the bottom half of the Front Left Seat of your model NISSAN GT-R (R35).

### PARTS LOCATION

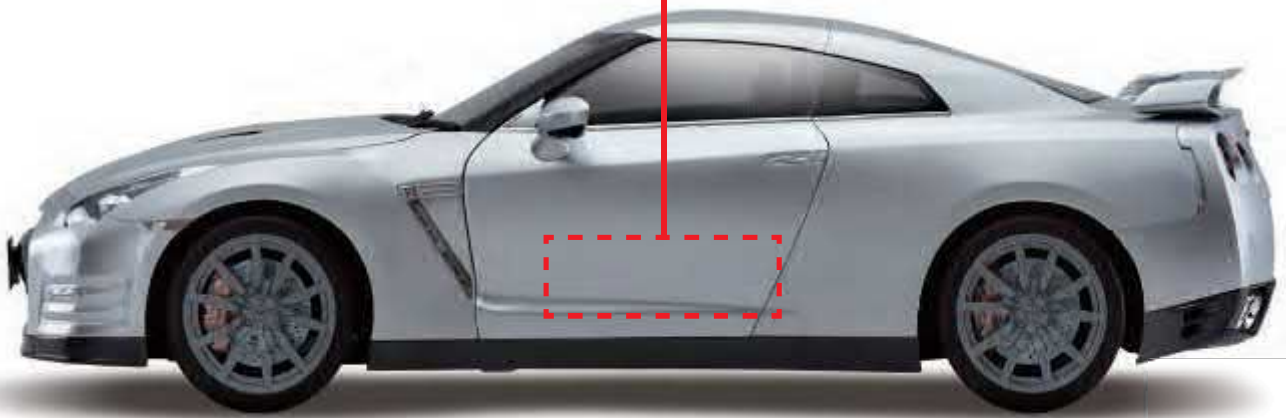

### PARTS LIST



#### TIP!

The Seat Belt Buckle has an 'L' printed on the back, indicating that it should be fitted to the Front Left Seat.

### PART IDENTIFICATION LIST

PART No.	NAME	QUANTITY	MATERIAL
27A	Seat Base	1	ABS
27B	Seat Belt Buckle	1	ABS
27C	Adjustable Bar	1	ABS
27D	Holder Rack	1	ABS
Screws	Type GP 0.08 x 0.16" [2 x 4mm]	8 [+2 spare]	Metal



27A



27B

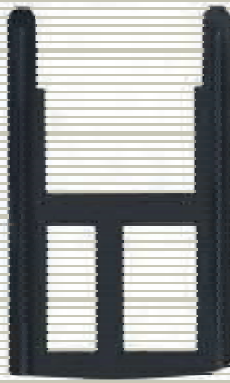

27C



27D

## STEP 01

### Position the Adjustable Bar

Place the Adjustable Bar [27C] on top of the Holder Rack [27D], as indicated in the illustration. The Adjustable Bar should be able to slide smoothly back and forth.

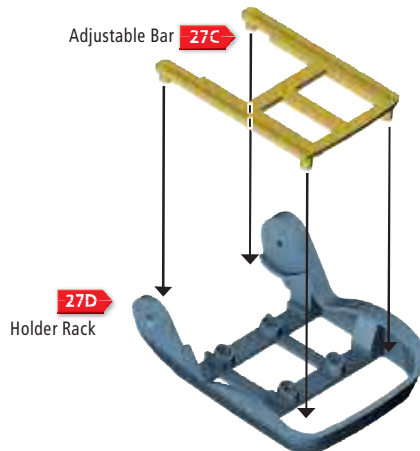

#### COLOR KEY

- PART BEING FITTED
- PART BEING FITTED TO
- FIXINGS

#### STEP 01 COMPLETE

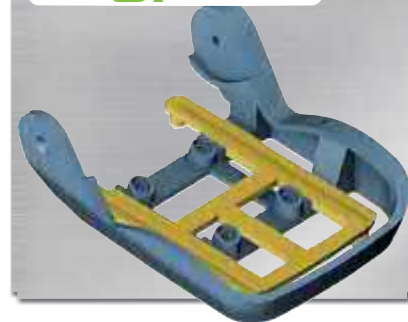

## STEP 02

### Position the Seat Base

Place the Seat Base [27A] on top of the combined Adjustable Bar/Holder Rack [27C/D]. The four pegs on the underside of the Seat Base should slot into the four holes indicated on the Holder Rack and the Adjustable Bar should still be able to slide back and forth.

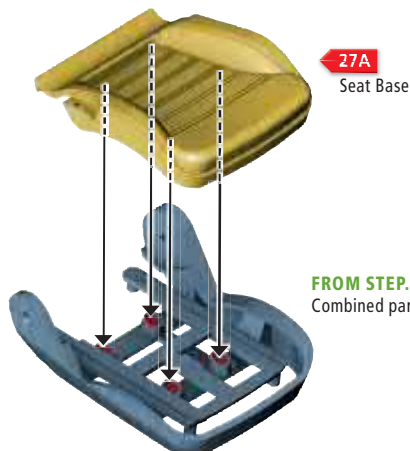

#### STEP 02 COMPLETE



## STEP 03

### Secure the Seat Base

Holding all the parts firmly together, turn them over and securely fasten the Seat Base [27A] into the holes on the Holder Rack [27D] using four TYPE GP screws, as indicated in the illustration. The Adjustable Bar should still be able to slide back and forth.

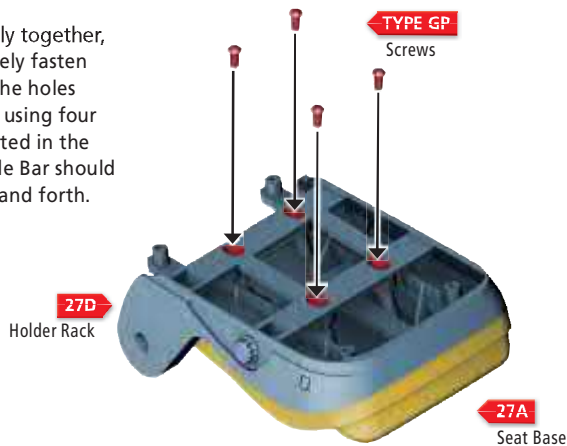

#### STEP 03 COMPLETE



## STEP 04 Attach the Seat Belt Buckle

Push the peg on the Seat Belt Buckle [27B] into the hole indicated on the Seat Base [27A]. It will hold securely in place without the need for screws.



### TIP!

Make sure the 'L' printed on the back of the Seat Belt Buckle faces inwards towards the Front Left Seat.

## Complete!

### The Front Left Seat Base

Next, you will complete the assembly of the Front Left Seat and attach it to the Interior Base.

### TIP!

Make sure the Seat Base isn't screwed too tightly to the Holder Rack and that the Adjustable Bar can still move back and forth.



# THE FRONT LEFT SEAT

Now you will complete the assembly of the Front Left Seat for your model NISSAN GT-R (R35).

## PARTS LOCATION

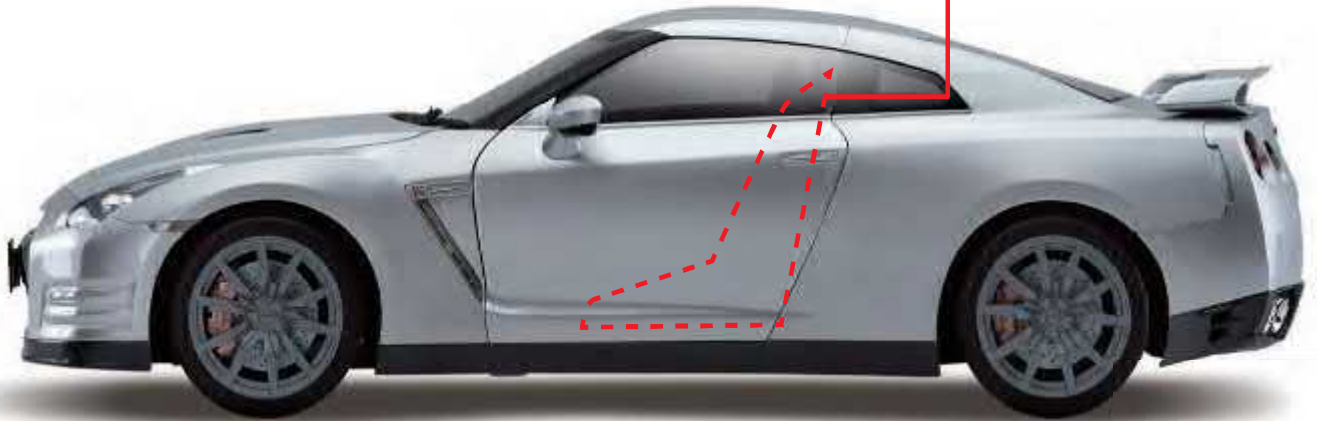

## PARTS LIST

### PART IDENTIFICATION LIST

PART No.	NAME	QUANTITY	MATERIAL
28A	Seat Back	1	ABS
28B	Seat Back Panel	1	ABS
28C	Seat Back Cover	1	ABS
Screws	Type GP 0.08 x 0.16" [2 x 4mm]	4 [+1 spare]	Metal
Screws	Type KP 0.07 x 0.3" [2 x 8mm]	2 [+1 spare]	Metal

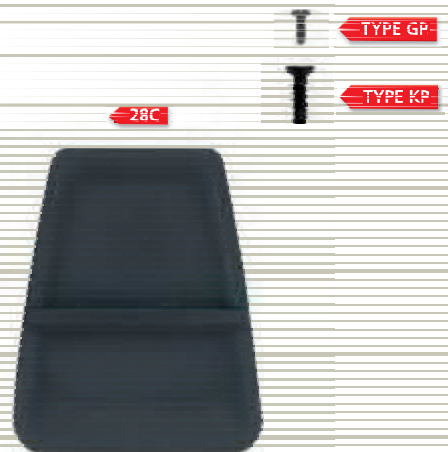

# HOW TO BUILD

## STEP 01 Combine the Seat Back and Seat Back Panel

Push the four pegs on the Seat Back [28A] into the Seat Back Panel [28B], ensuring that the peg at the head of the Seat Back goes into the corresponding hole in the Seat Back Panel. Now, secure the two halves together with four TYPE GP screws.

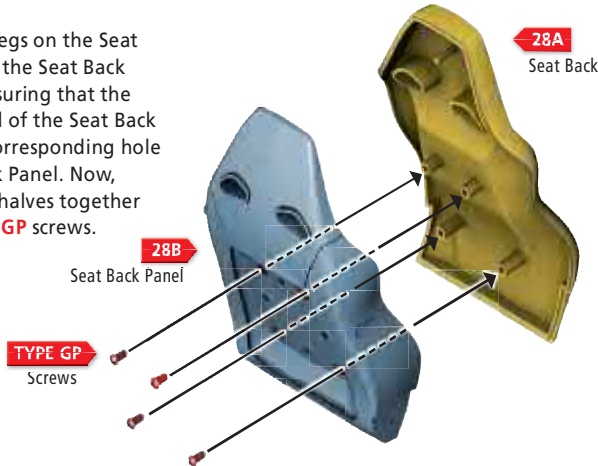

### COLOR KEY

- PART BEING FITTED
- PART BEING FITTED TO
- FIXINGS



## STEP 02 Attach the Seat Back Cover

Push the four pegs on the Seat Back Cover [28C] into the holes indicated on the Seat Back Panel [28B]. These parts just push together and do not require any screws.

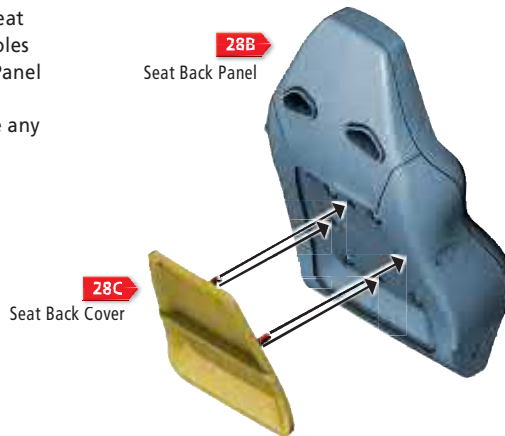

## STEP 03 Attach the Seat Back to the Seat Base

Slot the combined Seat Back parts **FIG. 1** between the struts of the Seat Base. Secure them together with two TYPE KP screws in the holes indicated in **FIG. 2**.

FROM PAGE 22  
Combined parts



FROM STEP 02  
Combined parts



## STEP 04

### Add the Front Left Seat to the Interior Base

Push the pegs on the Adjustable Bar [27C] located under the combined Front Left Seat into the four holes of the Interior Base [23A], as indicated in the illustration.



## STEP 05

### Secure the Front Left Seat to the Interior Base

Holding the combined Front Left Seat firmly in place, turn the Interior Base [23A] upside down and secure the parts together with four TYPE GP screws in the holes indicated in the illustration.

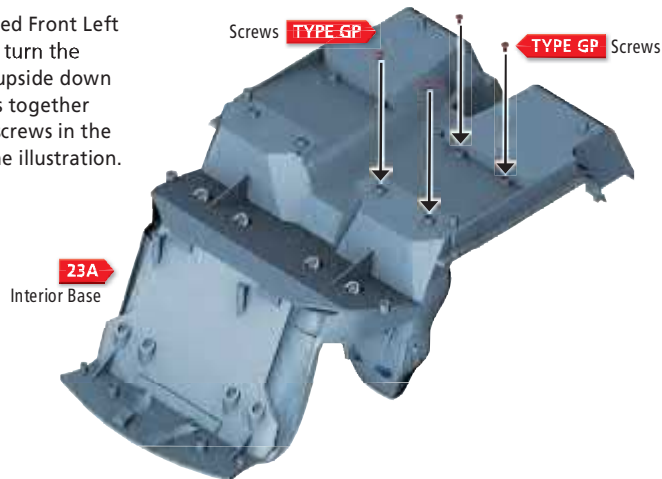

## Complete!

### The Front Left Seat

This stage of the interior is nearly complete. In the next section, you will begin assembling the Front Right Seat.



#### TIP!

The Front Left Seat should be able to slide back and forth by an inch or so (a few cm).

## THE FRONT RIGHT SEAT

Now it is time to assemble the bottom half of the Front Right Seat of your model NISSAN GT-R (R35).

### PARTS LOCATION

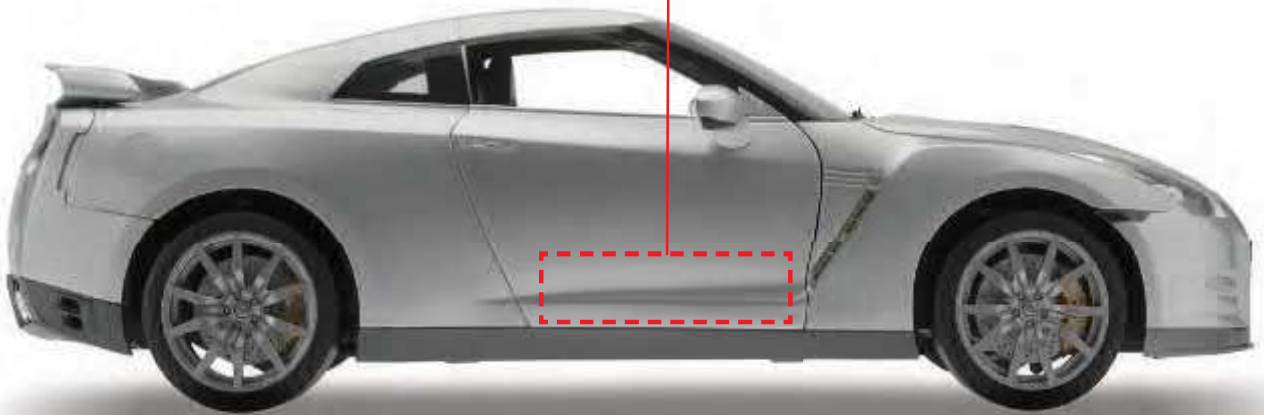

### PARTS LIST

#### TIP!

The Seat Belt Buckle has an 'R' printed on the back, indicating that it should be fitted to the Front Right Seat.



### PART IDENTIFICATION LIST

PART No.	NAME	QUANTITY	MATERIAL
29A	Seat Base	1	ABS
29B	Seat Belt Buckle	1	ABS
29C	Adjustable Bar	1	ABS
29D	Holder Rack	1	ABS
Screws	Type GP 0.08 x 0.16" [2 x 4mm]	8 [+2 spare]	Metal



29A



29B



29C



29D

## STEP 01

### Position the Adjustable Bar

Place the Adjustable Bar [29C] on top of the Holder Rack [29D], as indicated in the illustration. The Adjustable Bar should be able to slide smoothly back and forth.

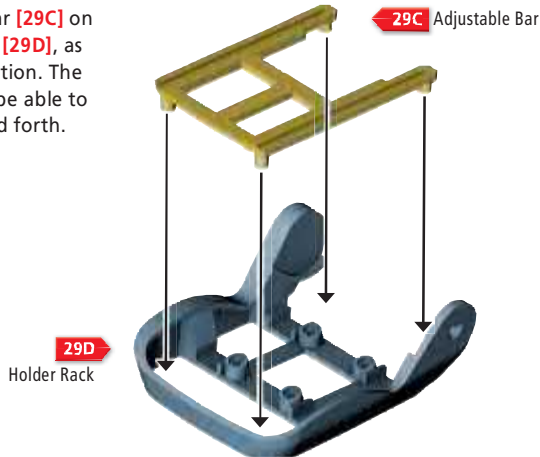

#### COLOR KEY

- PART BEING FITTED
- PART BEING FITTED TO
- FIXINGS



## STEP 02

### Position the Seat Base

Place the Seat Base [29A] on top of the combined Adjustable Bar/Holder Rack [29C/D]. The four pegs on the underside of the Seat Base should slot into the four holes on the Holder Rack and the Adjustable Bar should still be able to slide back and forth.

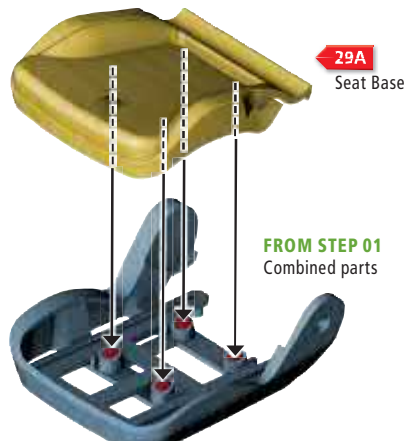

## STEP 03

### Secure the Seat Base

Holding all the parts firmly together, turn them over and secure the Seat Base [29A] into the holes indicated on the Holder Rack [29D] using four Type GP screws in the holes indicated in the illustration. Again, the Adjustable Bar should still be able to slide back and forth.

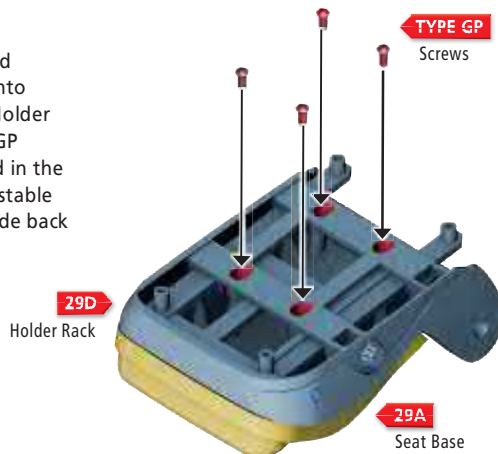



# HOW TO BUILD

## STEP 04 Attach the Seat Belt Buckle

Push the peg on the Seat Belt Buckle [29B] into the hole indicated on the Seat Base [29A]. It will hold securely in place without the need for screws.

### TIP!

Make sure the 'R' printed on the back of the Seat Belt Buckle faces inwards towards the Front Right Seat.



## Complete! The Front Right Seat Base

Next, you will complete the assembly of this Front Right Seat and attach it to the Interior Base.

### TIP!

Make sure you keep the remaining Type GP screws safe, as they will be needed later.



# THE FRONT RIGHT SEAT

Now it is time to complete the assembly of the Front Right Seat for your model NISSAN GT-R (R35).

## PARTS LOCATION

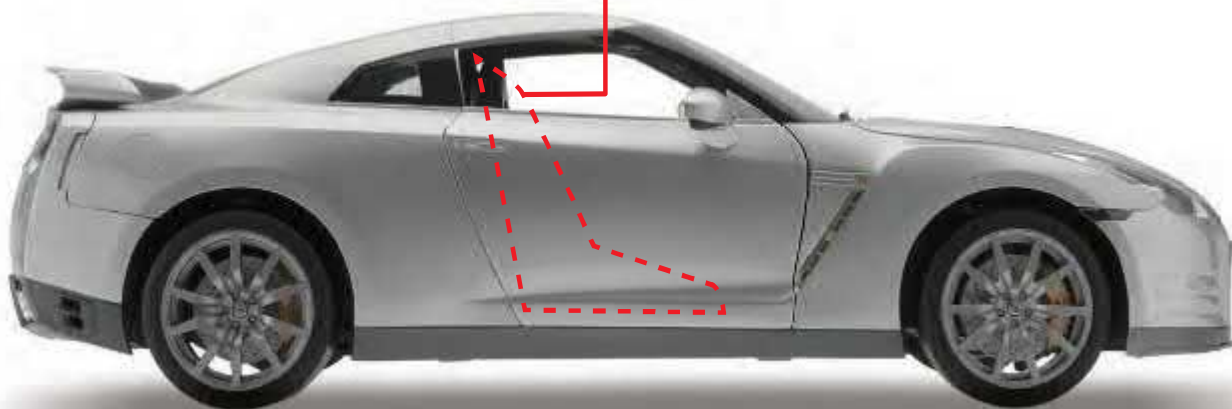

## PARTS LIST

### PART IDENTIFICATION LIST

PART No.	NAME	QUANTITY	MATERIAL
30A	Seat Back	1	ABS
30B	Seat Back Panel	1	ABS
30C	Seat Back Cover	1	ABS
Screws	Type GP 0.08 x 0.16" [2 x 4mm]	4 [+1 spare]	Metal
Screws	Type KP 0.07 x 0.3" [2 x 8mm]	2 [+1 spare]	Metal

30A

30B



30C



TYPE GP

TYPE KP

## STEP 01

### Combine the Seat Back and Seat Back Panel

Push the four pegs on the Seat Back [30A] into the Seat Back Panel [30B], ensuring that the peg at the head of the Seat Back goes into the corresponding hole in the Seat Back Panel. Now, secure the two halves together with four **TYPE GP** screws.

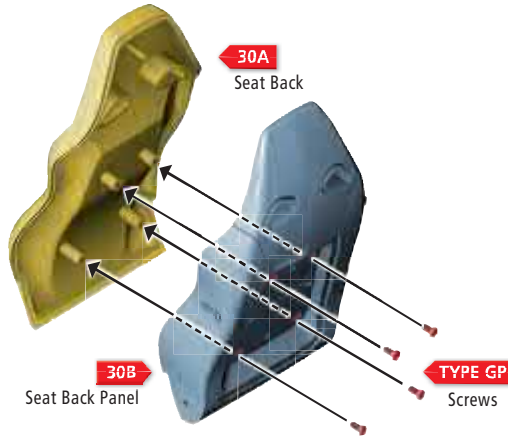

#### COLOR KEY

- PART BEING FITTED
- PART BEING FITTED TO
- FIXINGS

#### STEP 01 COMPLETE



## STEP 02

### Attach the Seat Back Cover

Push the four pegs on the Seat Back Cover [30C] into the holes indicated on the Seat Back Panel [30B]. These parts just push together and do not require any screws.

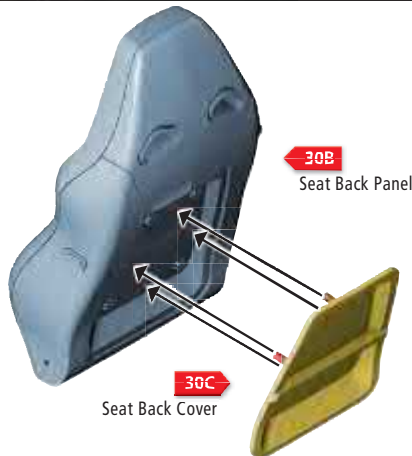

#### STEP 02 COMPLETE



## STEP 03

### Attach the Seat Back to the Seat Base

Slot the combined Seat Back parts between the struts of the Seat Base parts that you built earlier. Secure them together with two **TYPE KP** screws in the holes indicated in **FIG. 2**.

**FIG. 1**

**FROM STEP 02**  
Combined parts



**FROM PAGE 28**  
Combined parts

**FIG. 2**



#### STEP 03 COMPLETE



## STEP 04

### Add the Front Right Seat to the Interior Base

Push the pegs on the Adjustable Bar [29C] located under the combined Front Right Seat into the four holes of the Interior Base [23A], as indicated in the illustration.



## STEP 05

### Secure the Front Right Seat to the Interior Base

Holding the combined Front Right Seat firmly in place, turn the Interior Base [23A] upside down and secure the parts together with four TYPE GP screws in the holes indicated in the illustration.

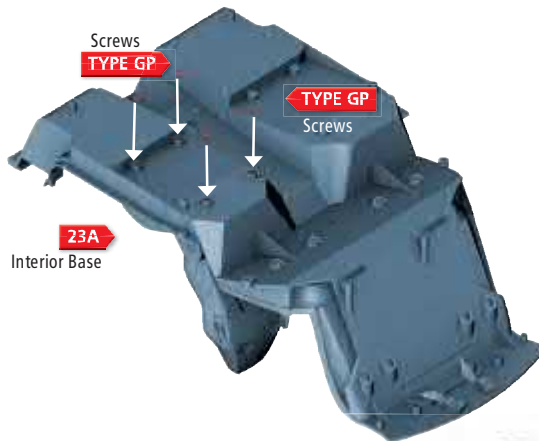

## Complete!

### The Front Right Seat

This stage of the interior construction is now complete. Keep this section in a safe place, as more parts will be added to it later.



### TIP!

The Front Right Seat should be able to slide back and forth by an inch or so (a few cm).

## THE REAR CHASSIS

In this section of the build, you will attach the Rear Exhaust Holder that came with **Magazine 05** to the Rear Chassis of your model NISSAN GT-R (R35).

### PARTS LOCATION

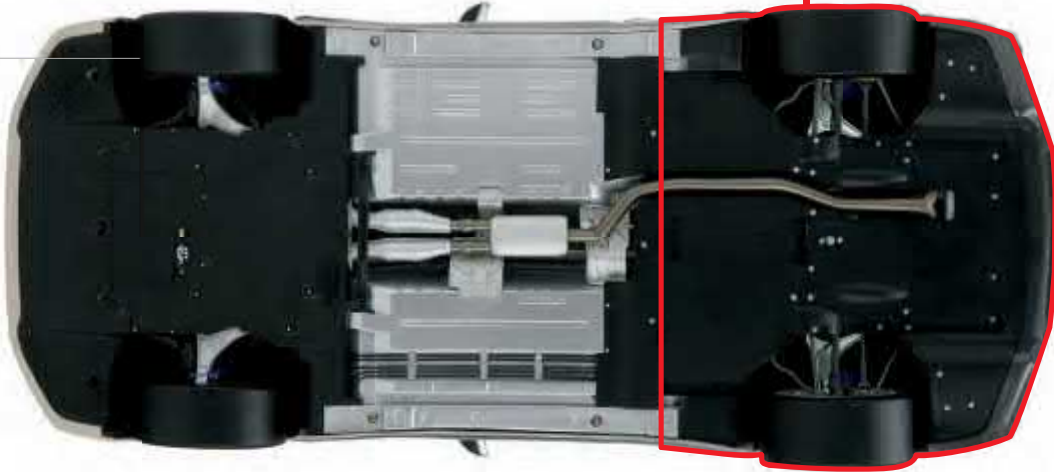

### PARTS LIST

#### PART IDENTIFICATION LIST

PART No.	NAME	QUANTITY	MATERIAL
<b>31A</b>	Rear Chassis	1	Zinc
<b>Screws</b>	Type GP 0.07 x 0.16" [2 x 4mm]	2 [+1 spare]	Metal

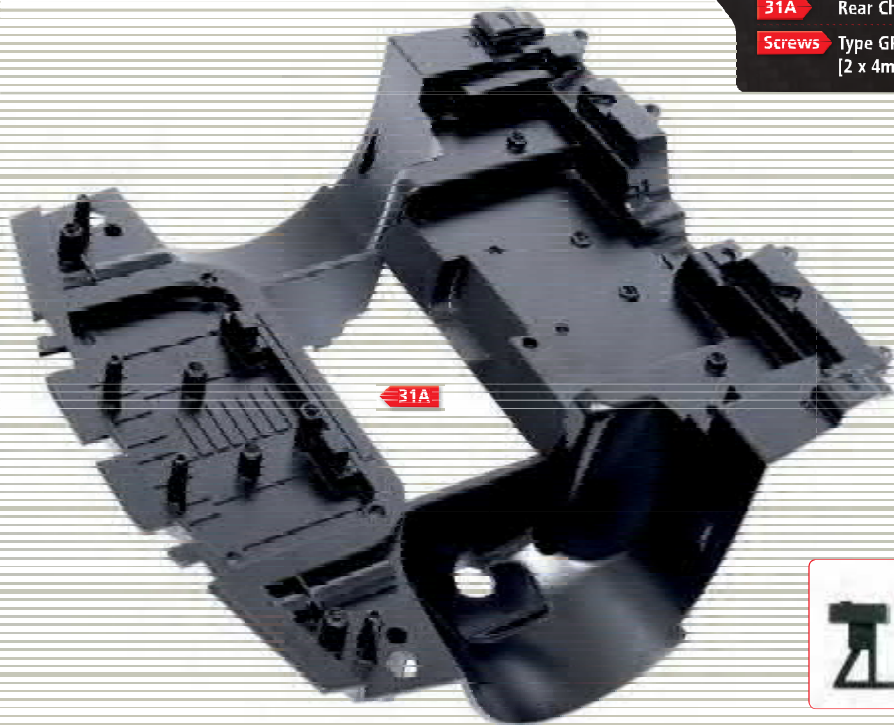

#### TIP!

You will need the Rear Exhaust Holder (shown below) that came with Magazine 05 for this assembly.



## STEP 01

### Add the Rear Exhaust Holder

Slot the two pegs on the underside of the Rear Exhaust Holder [15A] into the two holes on the Rear Chassis [31A], as indicated in the illustration. Make sure you put the Rear Exhaust Holder in the correct way round.

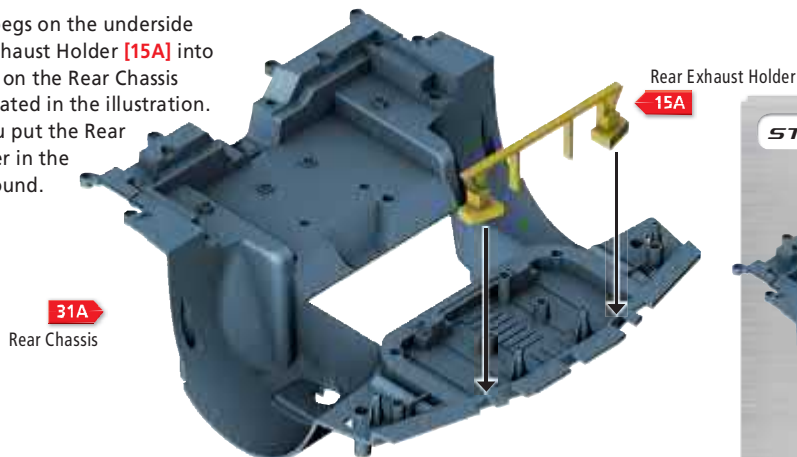

#### COLOR KEY

- PART BEING FITTED
- PART BEING FITTED TO
- FIXINGS

### STEP 01 COMPLETE

## STEP 02

### Secure the Rear Exhaust Holder to the Rear Chassis

Holding the Rear Exhaust Holder [15A] firmly in place, turn the Rear Chassis [31A] over and secure the parts together with two **TYPE GP** screws in the holes indicated in the illustration.

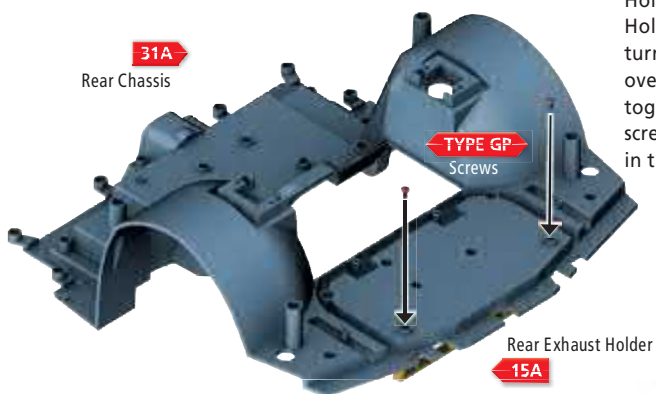

### STEP 02 COMPLETE

## Complete!

### The Rear Chassis

The Rear Exhaust Holder is just the first part that will be attached to the Rear Chassis. More car parts will be added to the Chassis over the following pages.



#### TIP!

The Rear Exhaust Holder will hold the car's Exhaust in place when it is added later.

## THE FRONT CHASSIS

Now you will attach the Front Chassis to the Rear Chassis of your model NISSAN GT-R (R35).

### PARTS LOCATION

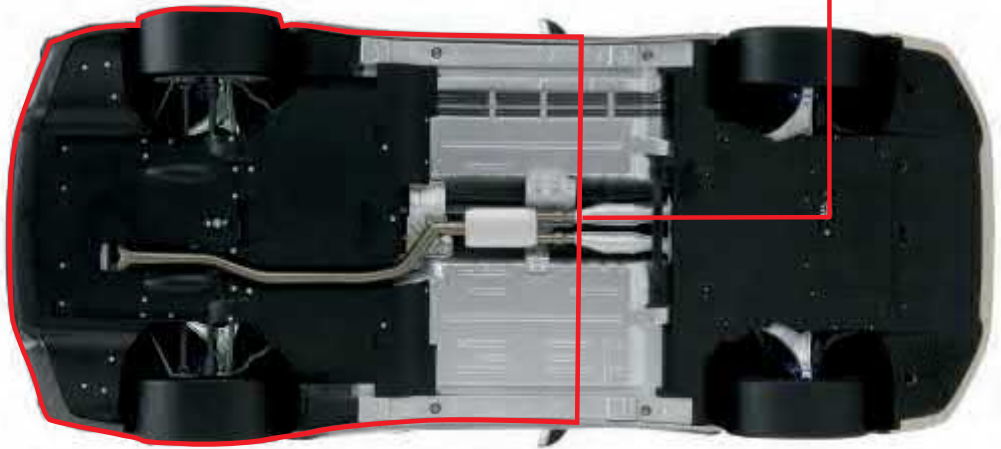

### PARTS LIST

#### PART IDENTIFICATION LIST

PART No.	NAME	QUANTITY	MATERIAL
32A	Front Chassis	1	Zinc
Screws	Type AM 0.1 x 0.16" [2.6 x 4mm]	4 [+2 spare]	Metal



32A

## STEP 01

### Join the Front Chassis to the Rear Chassis

#### COLOR KEY

- PART BEING FITTED
- PART BEING FITTED TO
- FIXINGS

Place the four struts on the Rear Chassis [31A] over the holes on the Front Chassis [32A], as indicated in the illustration, so that the two halves line up precisely.



## STEP 02

### Secure the Rear Chassis to the Front Chassis

Holding the two halves together, secure the Rear Chassis [31A] to the Front Chassis [32A] by using four TYPE AM screws in the holes indicated in the illustration.

31A  
Rear Chassis

TYPE AM  
Screws

32A  
Front Chassis





## Complete!

### The Chassis

The combined Chassis forms the underlying structure of your model and many more auto parts will be added to it.

Top view of Chassis

Bottom view of Chassis

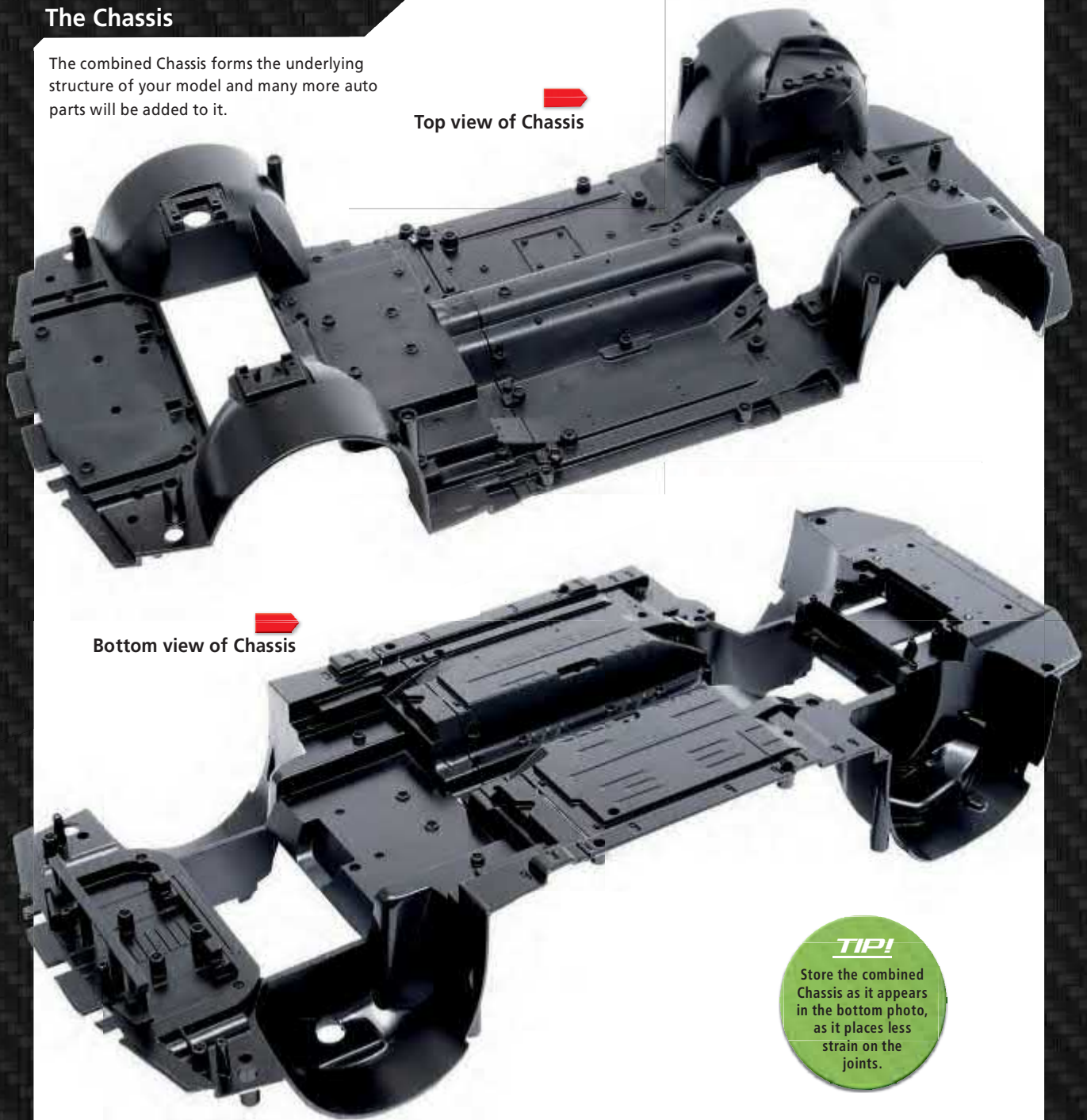

#### **TIP!**

Store the combined Chassis as it appears in the bottom photo, as it places less strain on the joints.

# THE FRONT AND REAR CHASSIS PARTS

Now you will add the Front and Rear Chassis Parts to your model's Front and Rear Chassis.

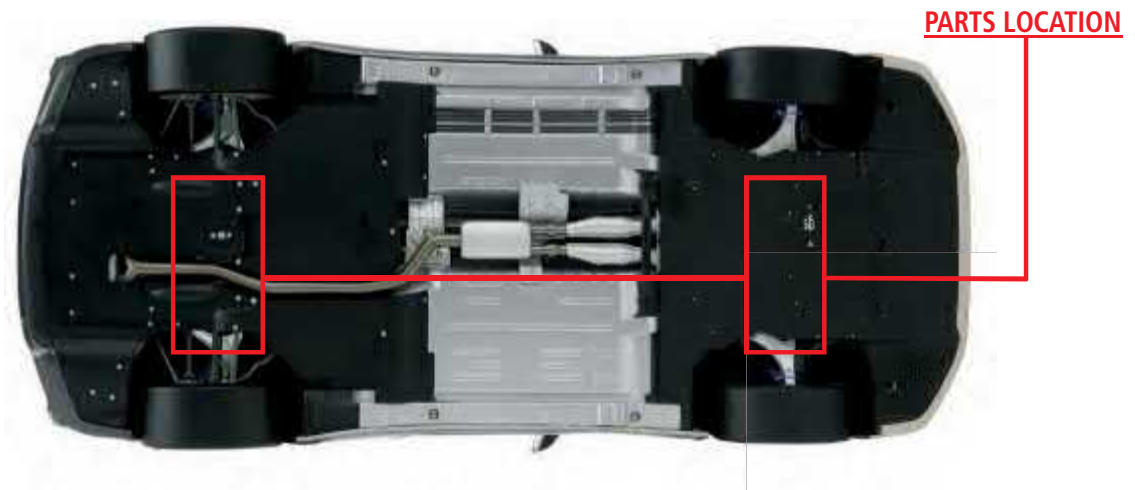

## PARTS LIST

### PART IDENTIFICATION LIST

PART No.	NAME	QUANTITY	MATERIAL
<b>33A</b>	Front Chassis Part	1	Zinc
<b>33B</b>	Rear Chassis Part	1	Zinc
<b>Screws</b>	Type AM 0.1 x 0.16" [2.6 x 4mm]	4 (+2 spares)	Metal
<b>Screws</b>	Type GM 0.07 x 0.16" [2 x 4mm]	4 (+2 spares)	Metal

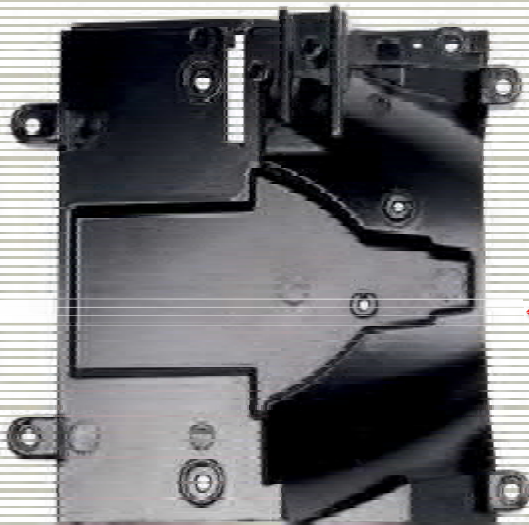

**33A**

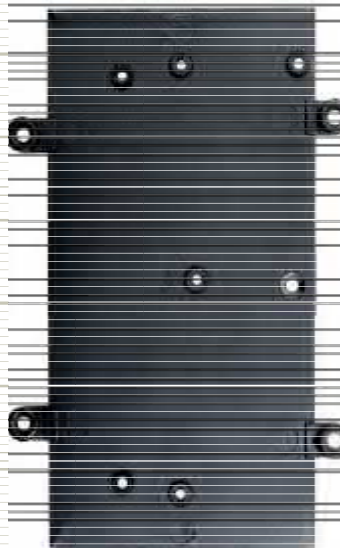

**33B**

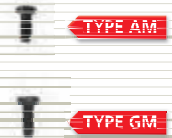

## STEP 01

### Add the Front Chassis Part

#### COLOR KEY

- PART BEING FITTED
- PART BEING FITTED TO
- FIXINGS

Place the Front Chassis Part [33A] onto the Front Chassis [32A] so that it covers the area indicated in the illustrations.

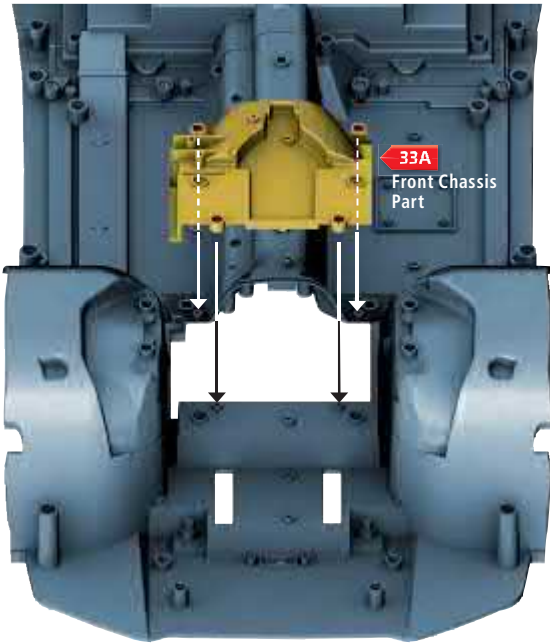

32A  
Front Chassis

## STEP 01 COMPLETE

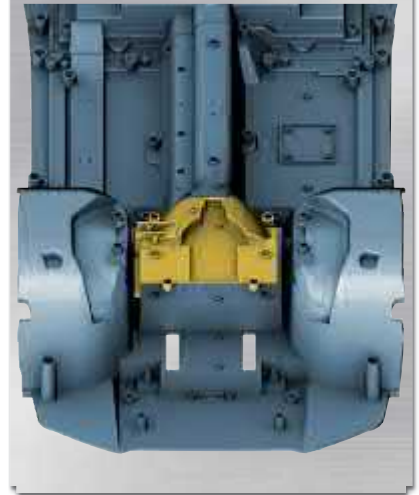

## STEP 02

### Secure the Front Chassis Part to the Front Chassis

Secure the Front Chassis Part [33A] to the Front Chassis [32A] with four **TYPE AM** screws in the holes indicated in the illustration.

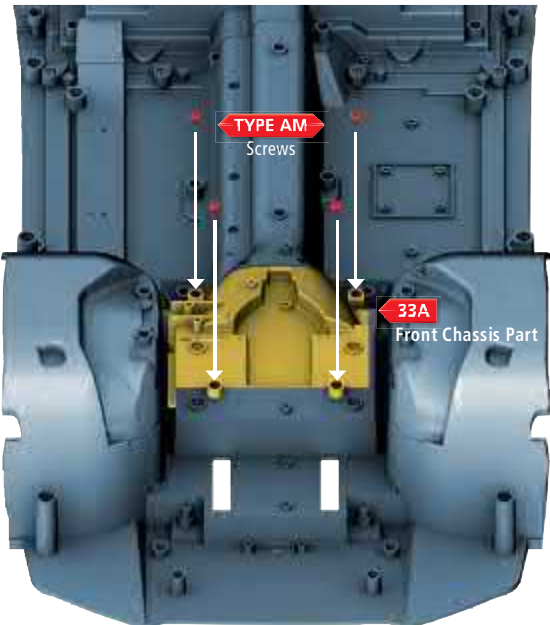

32A  
Front Chassis

## STEP 02 COMPLETE

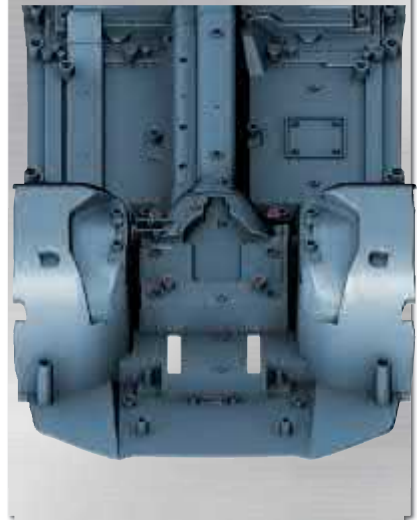

## STEP 03

### Attach the Rear Chassis Part to the Rear Chassis

FIG. 1

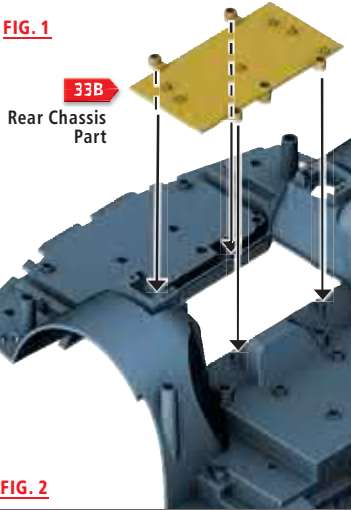

Place the Rear Chassis Part [33B] onto the Rear Chassis [31A] over the hole indicated in the illustration. Now, secure the parts together with four **TYPE GM** screws in the holes, as indicated in FIG. 2.

STEP 03 COMPLETE



FIG. 2

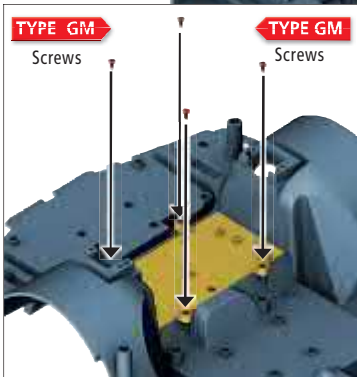

## Complete!

### Front and Rear Chassis

More parts will be added to the Chassis over the next few pages, including the Fuel Tank and the Rear Suspension and Wheels that you assembled previously.



## THE FUEL TANK AND CHASSIS PARTS

Now you will attach the Fuel Tank, the Rear Suspension Assembly, the Lower Half Shaft and Gear Shafts to your model NISSAN GT-R (R35).

### PARTS LOCATION

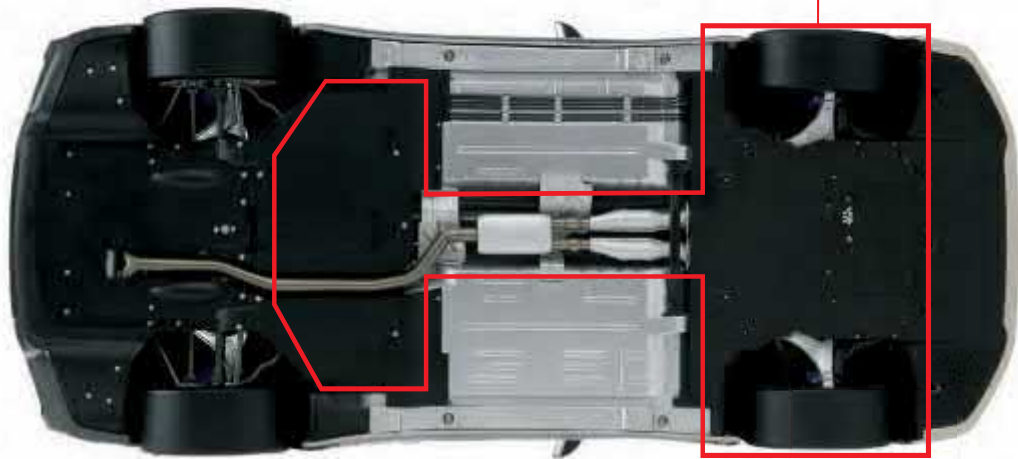

### PARTS LIST

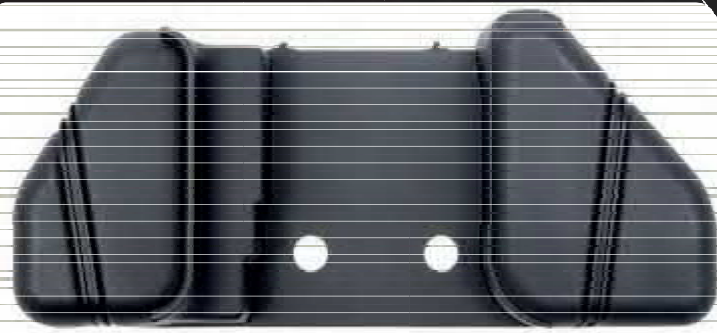

34A



34B



34C



34D

Lower Half Shaft & Gear Shafts from [Magazine 03](#)



08B



08C



08D

### PART IDENTIFICATION LIST

PART No.	NAME	QUANTITY	MATERIAL
34A	Fuel Tank	1	ABS
34B	Left Suspension Board	1	ZINC
34C	Right Suspension Board	1	ZINC
34D	Fixed Axis	2	ZINC
Screws	Type GP 0.07 x 0.16" [2 x 4mm]	4 [+2 spare]	Metal
Screws	Type HM 0.09 x 0.16" [2.3 x 4mm]	3 [+1 spare]	Metal
Screws	Type OM 0.1 x 0.19" [2.6 x 5mm]	8 [+4 spare]	Metal
Screws	Type GM 0.07 x 0.16" [2 x 4mm]	6 [+3 spare]	Metal



Rear Suspension Assembly from [Magazine 06](#)



## STEP 01

### Attach the Fuel Tank

Slot the Fuel Tank [34A] onto the Rear Chassis [31A] in the area indicated in the illustration.

Holding the Fuel Tank firmly in place, turn the Rear Chassis over and secure it in place with four TYPE GP screws in the holes shown in the illustration.

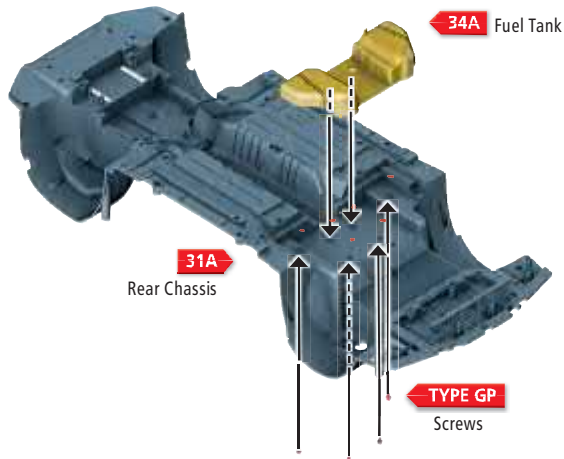

#### COLOR KEY

- PART BEING FITTED
- PART BEING FITTED TO
- FIXINGS



## STEP 02

### Attach the Rear Suspension Assembly

FIG. 1

FROM MAGAZINE 06  
Combined parts

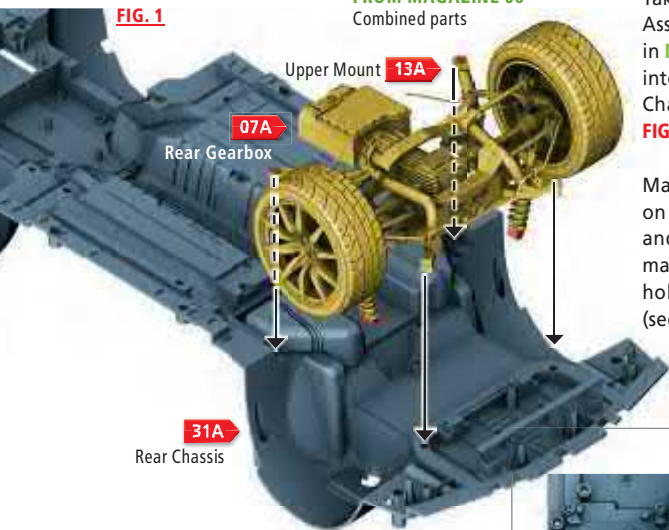

Take the Rear Suspension Assembly that you completed in Magazine 06 and slot it into the area of the Rear Chassis [31A], as indicated in FIG. 1, left.

Make sure that the holes on the Rear Gearbox [07A] and the Upper Mount [13A] match up with the correct holes on the Rear Chassis (see FIG. 2, right).

FIG. 2



Secure the Rear Gearbox in place with three TYPE HM screws. Now, use four TYPE OM screws to secure the Upper Mount to the Rear Chassis in the holes indicated in FIG. 3, right.

FIG. 3

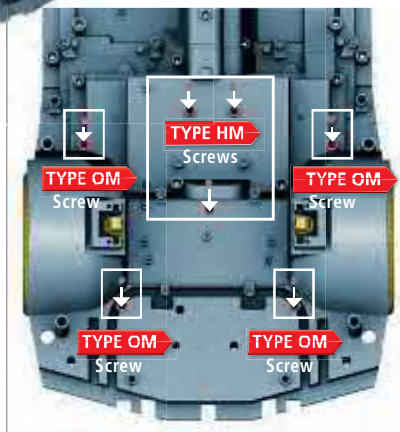

## STEP 03 Attach the Lower Half Shaft

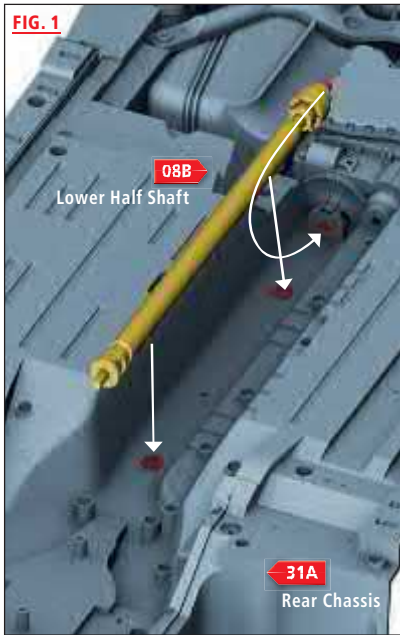

Place the Lower Half Shaft [08B] onto the Rear Chassis [31A] in the area indicated in the illustration, so that the struts on the bottom of the Lower Half Shaft

### TIP!

Put one end of the Lower Half Shaft into the Front Gearbox Section.

match up with the holes on the Rear Chassis, as shown in FIG.1.

Holding the Lower Half Shaft firmly in place, turn the Rear Chassis over and use two TYPE GM screws in the holes shown in FIG.2

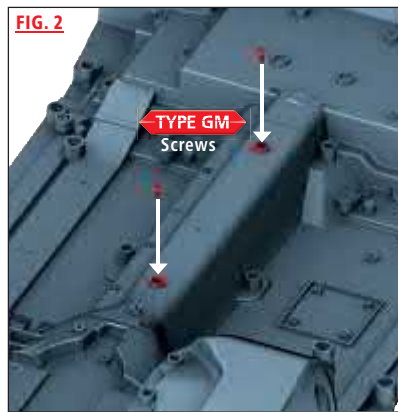

## STEP 04 Attach the Lower Gear Shafts

Slot the end of the Lower Gear Shaft (Rear) [08D] into the Front Gearbox Section and then place it and the Lower Gear Shaft (Front) [08C] onto the Rear Chassis [31A] so that the struts on the bottom of them go into the holes on the Rear Chassis, as indicated in FIG. 1.

Holding the Gear Shafts firmly in place, turn the Rear Chassis over and secure the parts together with four TYPE GM screws, as shown in FIG. 2.

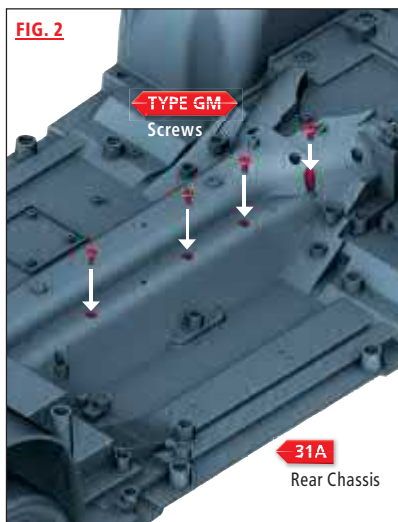
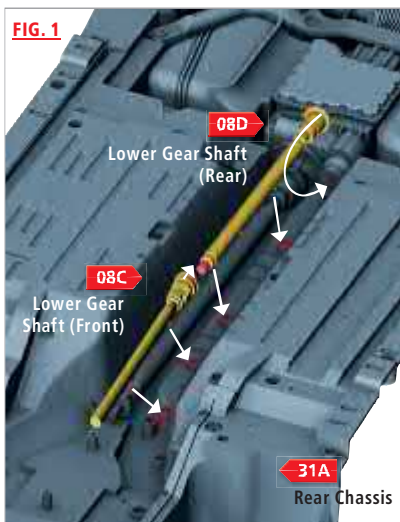

## Complete!

### Steps 3 and 4

This is how the Lower Half Shaft and the Lower Gear Shafts should look on the underside of the Chassis when you have completed Steps 3 and 4. Rather than securing both Lower Gear Shafts to the Chassis at the same time, you may find it easier to first secure the Lower Gear Shaft (Rear) in place with the screws before you secure the Lower Gear Shaft (Front).

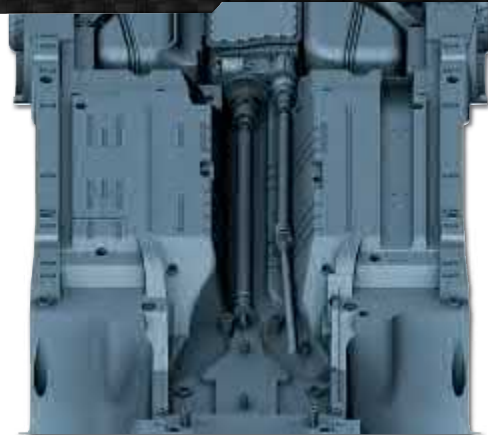

## STEP 05

### Secure the Left Rear Suspension Assembly

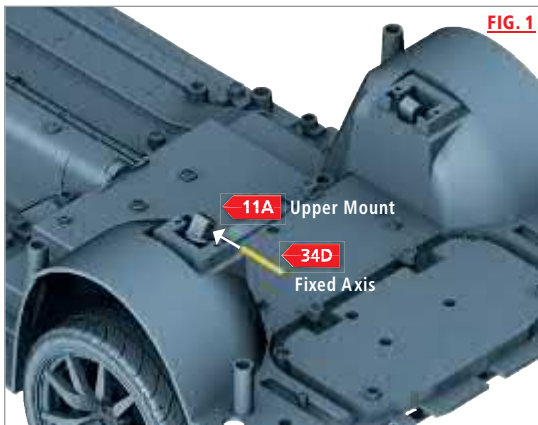

FIG. 1

Push one of the Fixed Axis [34D] through the holes at the top of the Upper Mount [11A], as shown in FIG.1, left.



FIG. 2

The Fixed Axis should sit neatly into its recess on the Rear Chassis [31A], as shown in FIG.2, right.

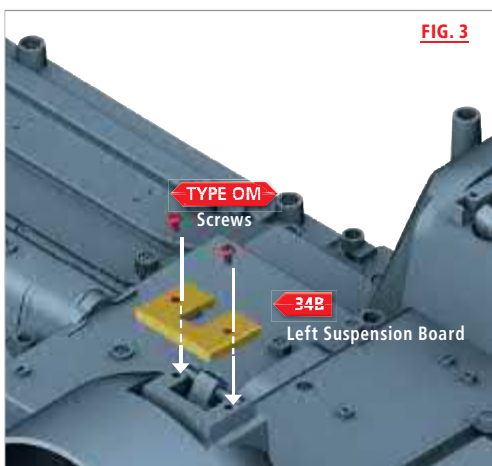

FIG. 3

Now, place the Left Suspension Board [34B] onto the Rear Chassis [31A] in the area indicated in FIG.3, left.

Secure the Left Suspension Board in place from above with two TYPE OM screws, as shown in FIG.3.





## STEP 06

### Secure the Right Rear Suspension Assembly

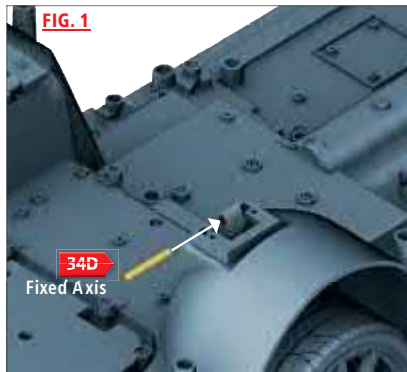

Push the second Fixed Axis [34D] through the holes at the top of the Upper Mount [04A], as shown in FIG.1, left. The Fixed Axis should sit neatly into its recess on the Rear Chassis [31A], as shown in FIG.2 below.

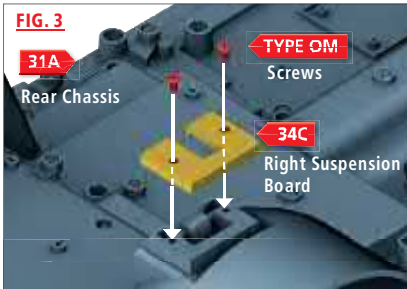
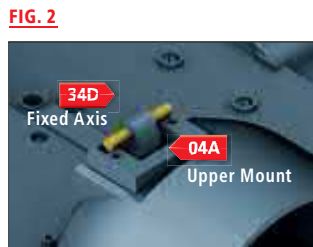

Now, place the Right Suspension Board [34C] onto the Rear Chassis [31A] in the area indicated in FIG.3, left. Secure the Right Suspension Board in place from above with two TYPE OM screws, as shown.



**Complete!**  
Fuel Tank & Chassis parts



This was one of the more complex parts of the Chassis build, but you can now see how the different sections are coming together as you assemble your model.



# HOW TO BUILD

## THE CHASSIS CABLES

In this magazine, you will attach the Chassis Cables and their Large Brackets to your NISSAN GT-R (R35) model.

### PARTS LOCATION

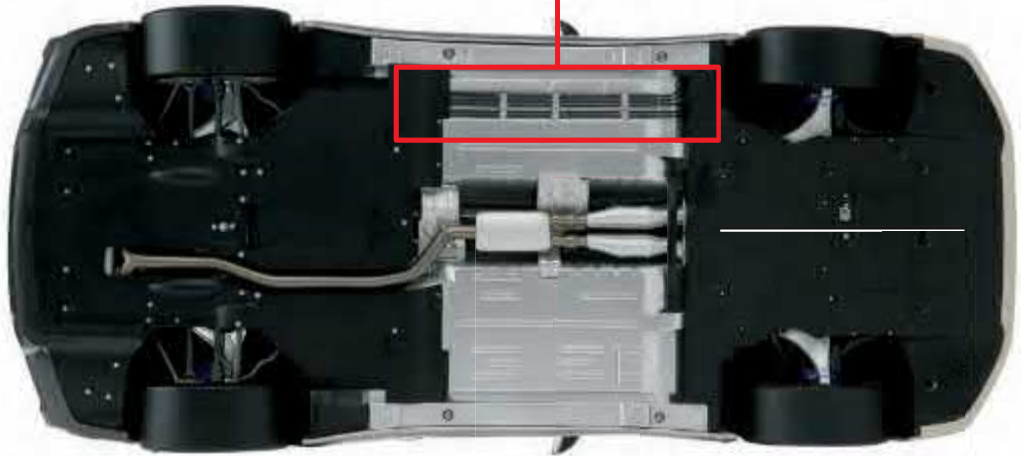

### PARTS LIST

#### PART IDENTIFICATION LIST

PART No.	NAME	QUANTITY	MATERIAL
35A	Chassis Cables	1	ABS + PVC
35B	Large Brackets	3	ABS
	Forceps	1	Metal
Screws	Type MP 0.06 x 0.2" [1.7 x 4mm]	4 [+2 spare]	Metal



#### FORCEPS



## STEP 01

### Attach the Chassis Cables

The plastic strip on the end of the Chassis Cables [35A] has a peg on its underside. Slot this peg into the Rear Chassis [31A], in the hole shown in FIG 1. Holding the plastic strip in place, turn the Chassis over and secure it in place using a TYPE MP screw in the hole indicated in FIG 2.

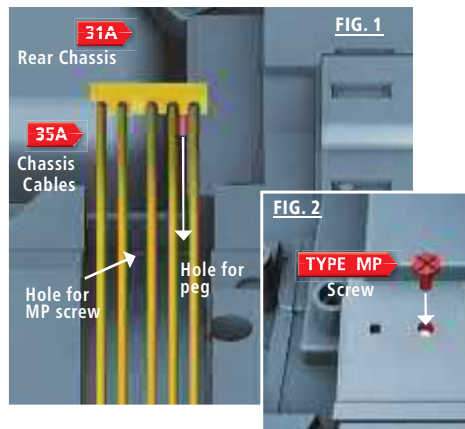

#### COLOR KEY

- PART BEING FITTED
- PART BEING FITTED TO
- FIXINGS



## STEP 02

### Attach the Large Brackets

The Large Brackets [35B] are used to hold the Chassis Cables in place and they should be attached and secured one by one.

Slot the peg on the underside of the first Large Bracket into a hole, as shown in the illustration (right), then go straight to STEP 3 to find out how to secure it in place, before repeating the process for the two remaining Large Brackets.

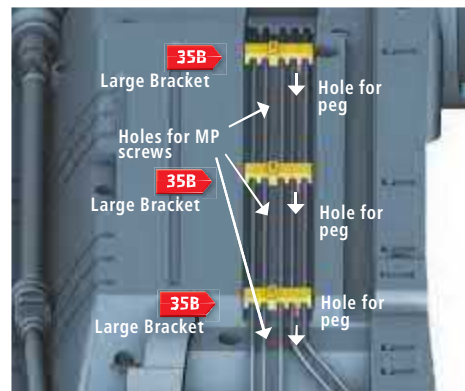

## STEP 03

### Secure the Large Brackets

Holding the Large Brackets (35B) in place, turn the Chassis over and use one TYPE MP screw in each of the three holes indicated, right. Attach and secure the Large Brackets one by one to make it easier. It does not matter which order you do them in.

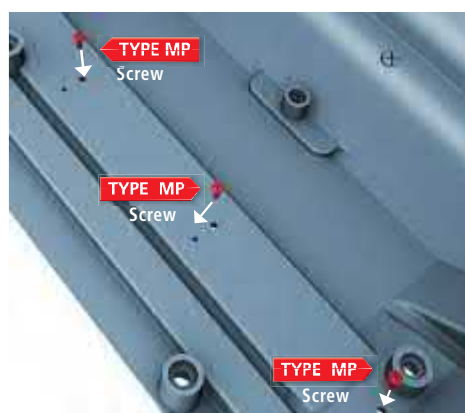

## STEP 04 Thread the Chassis Cables through the Medium and Small Brackets

Use the Forceps supplied with this magazine to help you thread the end of the Chassis Cables [35A] through the holes of the two Medium Brackets and the Small Bracket that are already attached to the Chassis. Three of the cables go through the Medium Brackets to the right and two cables go through the Small Bracket to the left.

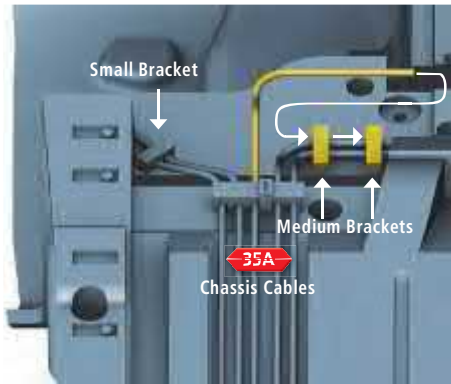

## Complete!

### Chassis Cables & Brackets

This is how the Chassis Cables and Brackets should look once you have finished this section of the build.



# THE OIL PAN

Now you will attach the Oil Pan, Rear Cross Member and Lower Chassis Plate to the Chassis of your model.

## PARTS LOCATION

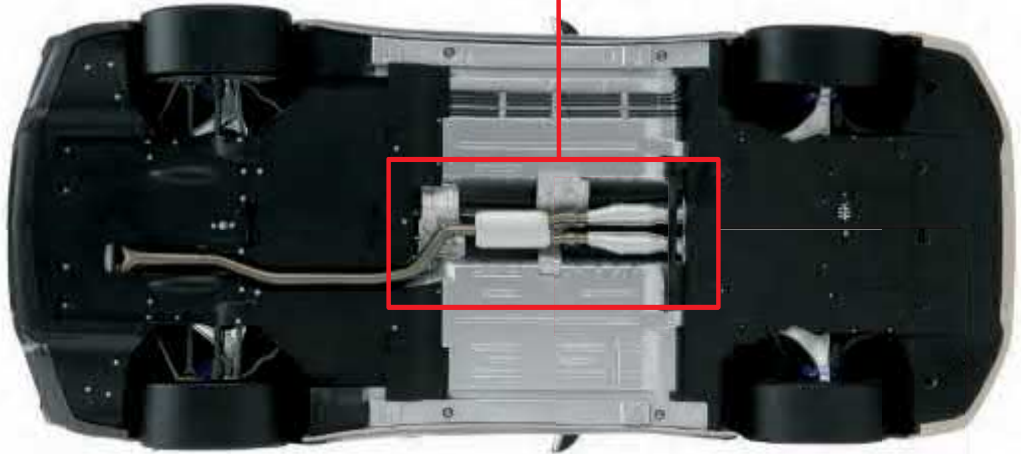

## PARTS LIST

### PART IDENTIFICATION LIST

PART No.	NAME	QUANTITY	MATERIAL
36A	Oil Pan	1	ABS
36B	Rear Cross Member	1	ABS
36C	Lower Chassis Plate	1	ABS
Screws	Type GP 0.07" x 0.16" [2 x 4mm]	2 [+1 spare]	Metal
Screws	Type HP 0.09" x 0.16" [2.3 x 4mm]	2 [+1 spare]	Metal
Screws	Type LM 0.09" x 0.2" [2.3 x 6mm]	2 [+1 spare]	Metal

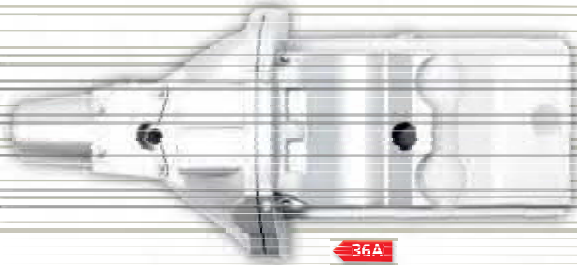

36A



36B



36C



TYPE GP



TYPE HP



TYPE LM

## STEP 01 Attach the Oil Pan

Place the Oil Pan [36A] on the bottom side of the Front Chassis [32A] so that the holes line up, as indicated in the illustration. Now, use two **TYPE LM** screws from above to secure the Oil Pan in place.

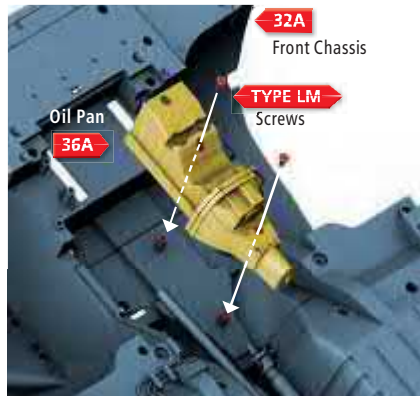

### COLOR KEY

- PART BEING FITTED
- PART BEING FITTED TO
- FIXINGS



## STEP 02 Attach the Lower Chassis Plate

Place the Lower Chassis Plate [36C] on the underside of the Chassis, as shown in the illustration. It should sit across the end of the Half Shafts, next to the Rear Gearbox and Fuel Tank.

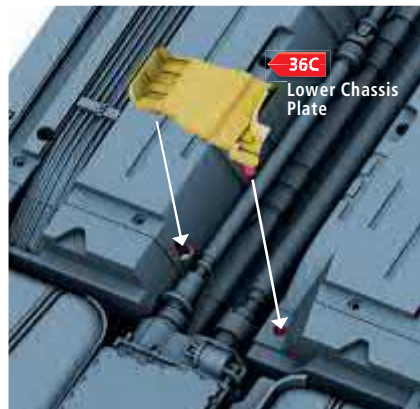

## STEP 03 Secure the Lower Chassis Plate

Holding the Lower Chassis Plate [36C] in place, turn the Chassis over and secure it in place with two **TYPE HP** screws in the holes indicated in the illustration.

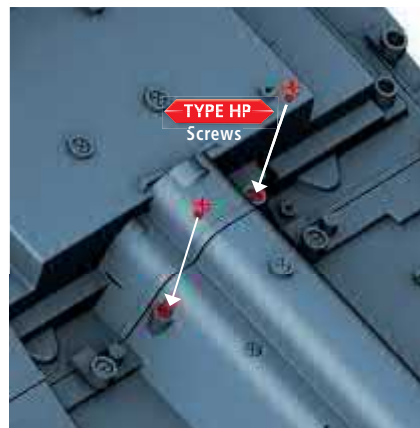

## STEP 04 Attach the Rear Cross Member

Place the Rear Cross Member [36B] on the underside of the Chassis, as shown in the illustration. It should sit in between the Lower Chassis Plate [36C] and the Rear Gearbox and Fuel Tank.



## STEP 05 Secure the Rear Cross Member

Holding the Rear Cross Member in place, turn the Chassis over and secure it in position with two TYPE GP screws in the holes indicated in the illustration.

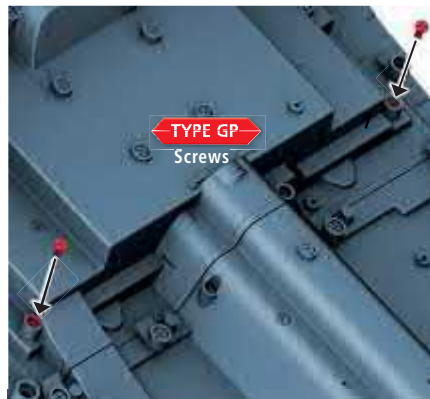

## Complete! Oil Pan, Plate & Rear Cross Member

This is how the Chassis should look now that you have added the latest parts.



### TIP!

If you're having difficulty, ask a friend to hold the parts in place while you tighten the screws.



## THE EXHAUST MIDDLE SECTION

Next, you will attach the Exhaust Middle Section to the Rear Exhaust Middle Section that you put together in [Magazine 05](#).

### PARTS LOCATION

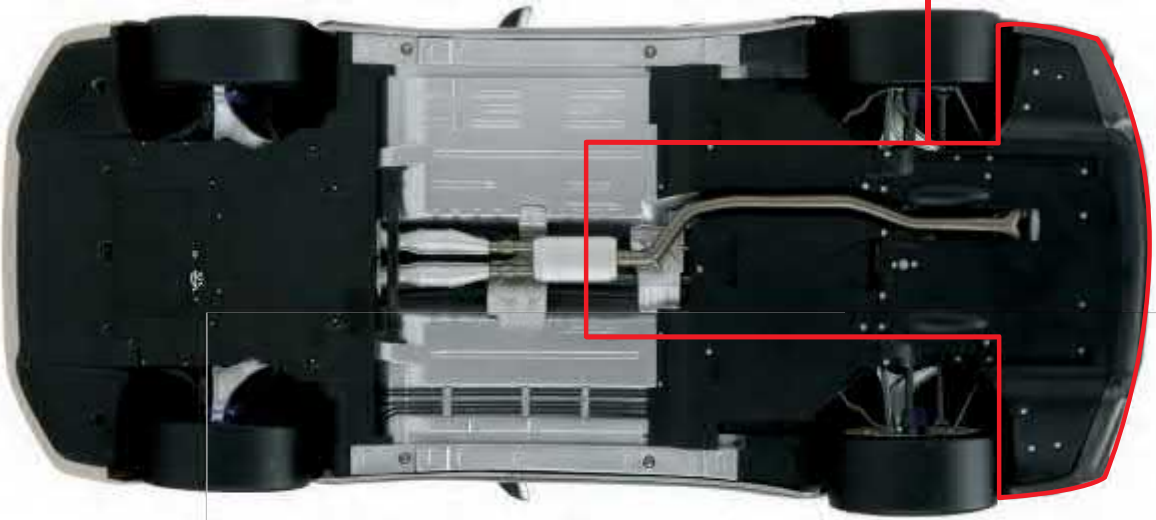

### PARTS LIST

#### PART IDENTIFICATION LIST

PART No.	NAME	QUANTITY	MATERIAL
37A	Exhaust Middle Section 1		ABS
Screws	Type GP 0.07 x 0.16" [2 x 4mm]	2 [+1 spare]	Metal



#### TIP!

This section requires the Rear Exhaust parts that came with Magazine 05 – see picture (right).

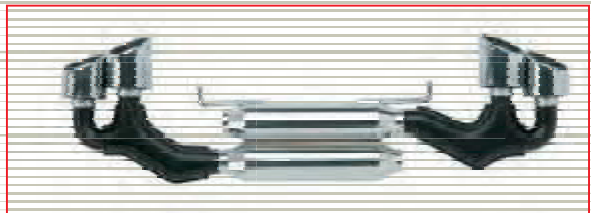

## STEP 01

### Attach the Exhaust Middle and Rear Sections

Line up the two holes at one end of the Exhaust Middle Section [37A] with the holes on the Rear Exhaust Middle Section [15B], as indicated in the illustration. Now, use two **TYPE GP** screws to secure the parts together.

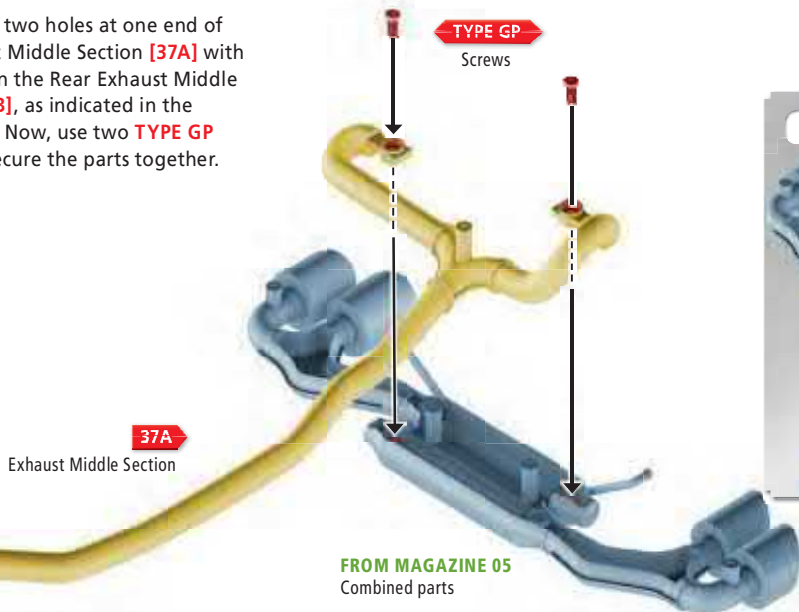

#### COLOR KEY

- PART BEING FITTED
- PART BEING FITTED TO
- FIXINGS



## Complete!

### The Exhaust Middle & Rear Sections

You will complete the assembly of the Exhaust System on the next few pages and attach it to the Chassis.

#### TIP!

Make sure the Exhaust Middle Section has been screwed into the correct holes on the Rear Exhaust Middle Section.



## THE EXHAUST FRONT SECTION

It is time to complete the assembly of the Exhaust System and attach it to the Chassis of your NISSAN GT-R (R35) model.

### PARTS LOCATION

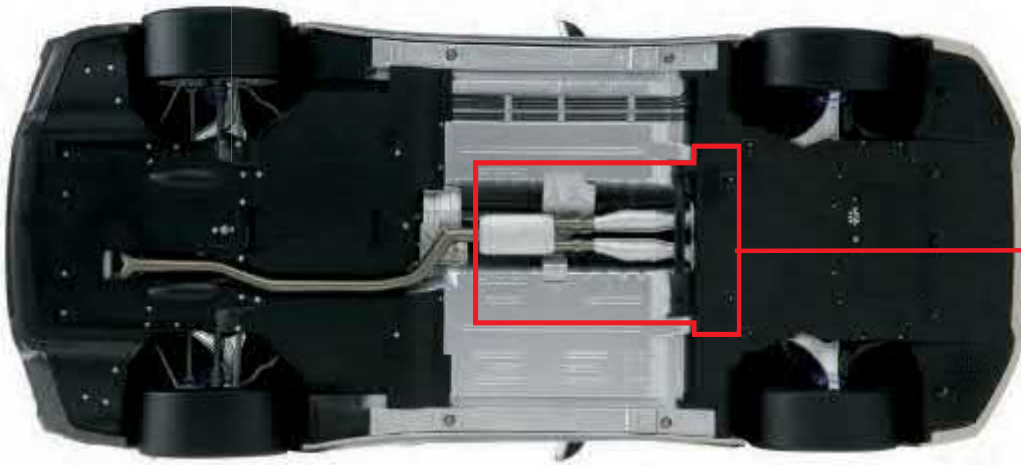

### PARTS LIST



### PART IDENTIFICATION LIST

PART No.	NAME	QUANTITY	MATERIAL
38A	Exhaust Front Section	1	ABS
38B	Middle Cross Member	1	ABS
38C	Front Cross Member Bar	1	ABS
Screws	Type HP 0.9 x 0.16" [2.3 x 4mm]	8 [+4 spare]	Metal
Screws	Type LP 0.9 x 0.2" [2.3 x 6mm]	7 [+5 spare]	Metal

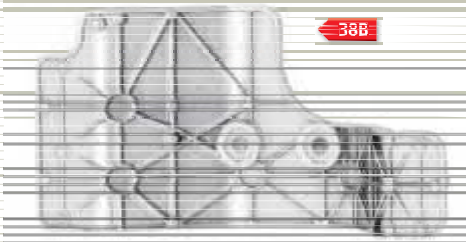
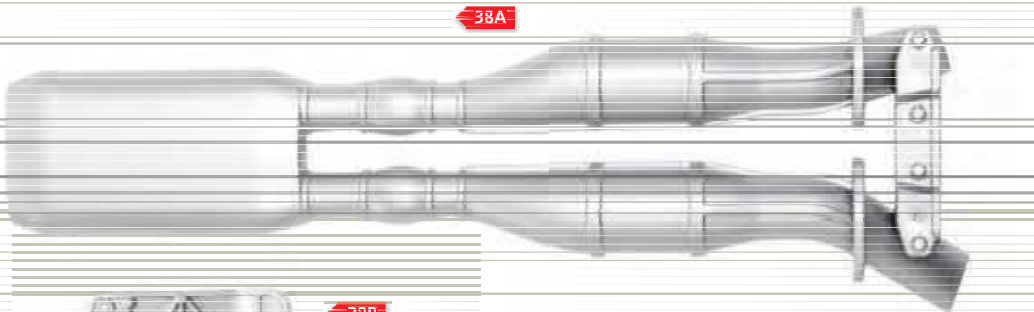

## STEP 01

### Attach the Exhaust Front Section

Line up the two holes at the end of the Exhaust Middle Section [37A] with the two struts on the Exhaust Front Section [38A], as shown in the illustration. Now, secure the two parts together with two **TYPE HP** screws.

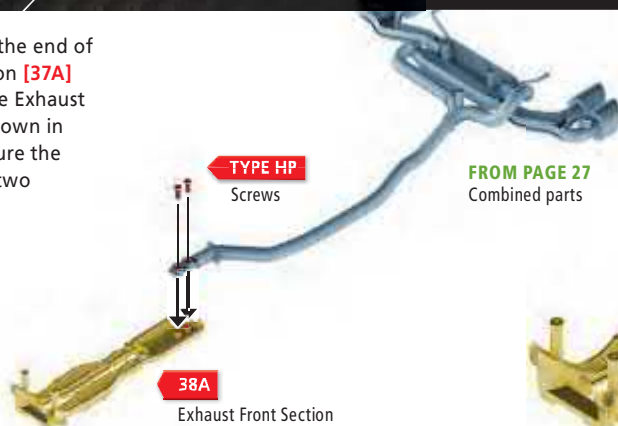

#### COLOR KEY

- PART BEING FITTED
- PART BEING FITTED TO
- FIXINGS

#### STEP 01 COMPLETE

## STEP 02

### Attach the Middle Cross Member

Line up the two holes in the Middle Cross Member [38B] with the two struts on the Exhaust Front Section [38A], as shown in the illustration. Now, secure the parts together with two **TYPE HP** screws.

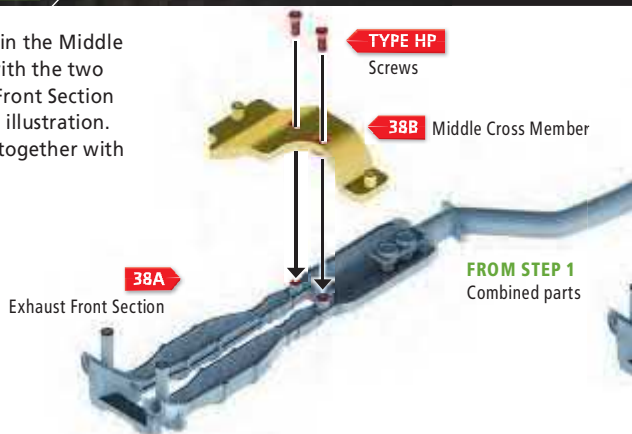

#### STEP 02 COMPLETE

## STEP 03

### Attach the Exhaust System to the Chassis

Place the entire Exhaust System that you have just completed onto the underside of the Chassis, so that all the struts fit into the holes indicated in the illustration.

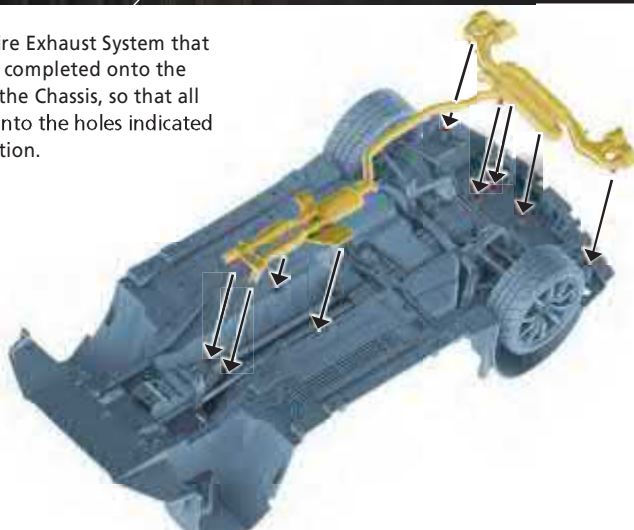

#### STEP 03 COMPLETE

## STEP 04 Secure the Exhaust Front Section to the Front Chassis

Holding the complete Exhaust System firmly in place, turn the Chassis over and secure the Exhaust Front Section [38A] to the Front Chassis [32A] with two **TYPE LP** screws in the holes shown in the illustration.

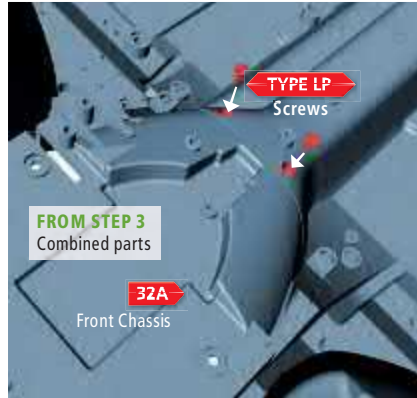

## STEP 05 Secure the Middle Cross Member to the Chassis

Secure the Middle Cross Member [38B] in place with two **TYPE HP** screws in the holes shown in the illustration.

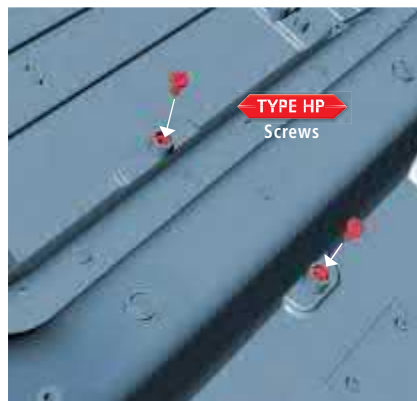

## STEP 06 Secure the Rear and Middle Sections of the Exhaust to the Chassis

Use five **TYPE LP** screws in the holes indicated in the illustration to secure the Rear Exhaust and the Exhaust Middle Section to your model's Chassis.

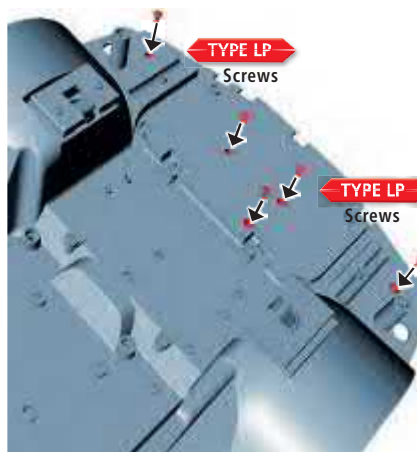

## STEP 07

### Attach the Front Cross Member Bar

Place the Front Cross Member Bar [38C] so that the struts underneath it go into the holes on the underside of the Front Chassis [32A], as indicated in the illustration.

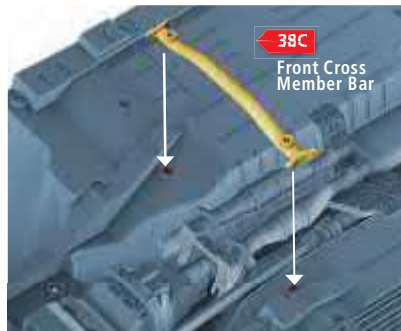

## STEP 08

### Secure the Front Cross Member Bar

Holding the Front Cross Member Bar [38C] firmly in place, turn the Chassis over and secure the part with two TYPE HP screws in the holes shown in the illustration.

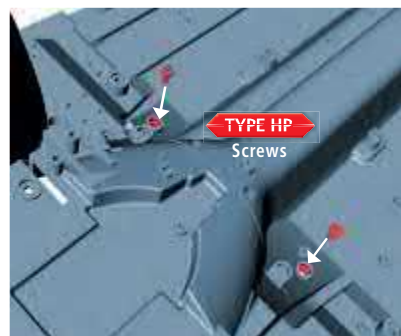

**Complete!**

### The Exhaust System

This picture shows how the completed Exhaust System should look now that it is attached to the Chassis.

## THE BATTERY COMPONENTS

In this magazine, you will attach the Battery Box, Cables and Holders to the Chassis of your model NISSAN GT-R (R35). Batteries will be used to power the car's headlights, brake lights and interior lights.

### PARTS LOCATION

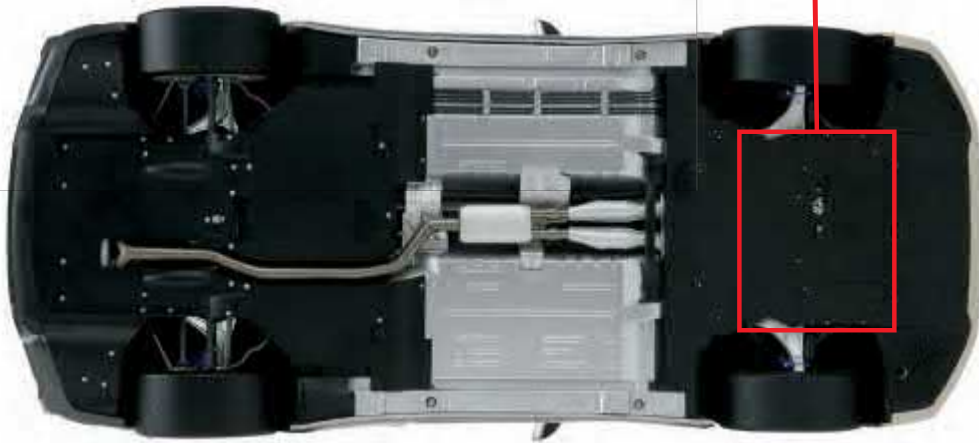

### PARTS LIST

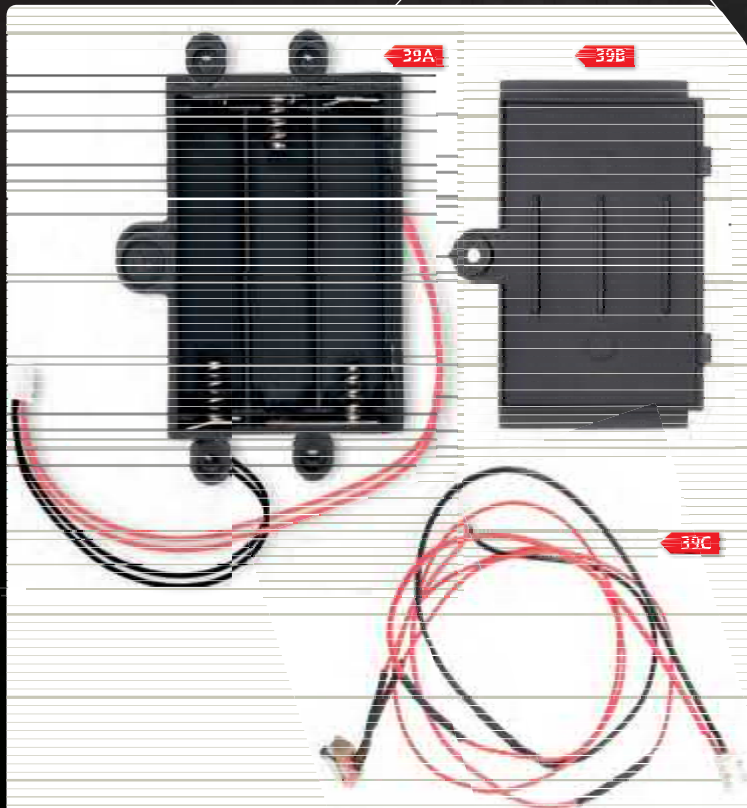

### PART IDENTIFICATION LIST

PART No.	NAME	QUANTITY	MATERIAL
39A	Battery Box & Cables	1	ABS
39B	Battery Cover	1	ABS
39C	ON/OFF Switch with Cable	1	
39D	Switch Holder	1	ABS
39E	Cable Holders	3	ABS
Screws	Type AM 0.1 x 0.16" [2.6 x 4mm]	6 [+3 spare]	Metal
Screws	Type DM 0.8 x 0.12" [2 x 3mm]	3 [+2 spare]	Metal
Screws	Type PM 0.8 x 0.2" [2 x 5mm]	1 [+1 spare]	Metal



## STEP 01

### Attach the Battery Box & Cables

Place the Battery Box & Cables [39A] on the bottom side of the Front Chassis [32A], as shown in FIG.1 (right), making sure that you first thread the Cables attached to the Battery Box through the hole in the Chassis.

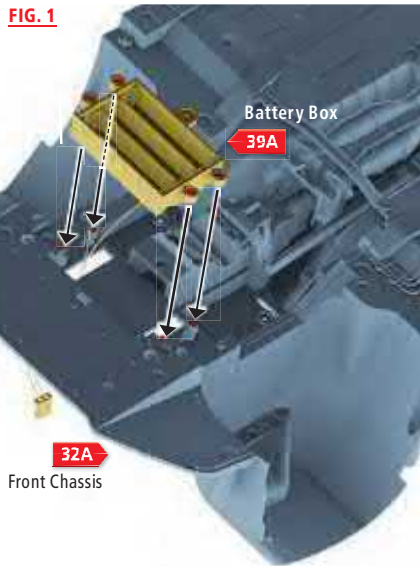
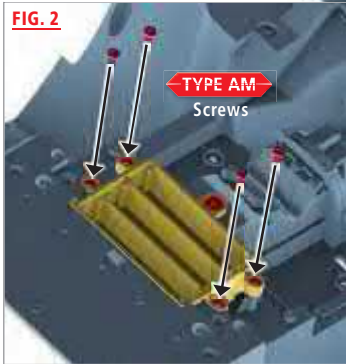

Secure the Battery Box [39A] to the Front Chassis [32A] with four TYPE AM screws, as shown in FIG.2.

#### COLOR KEY

- PART BEING FITTED
- PART BEING FITTED TO
- FIXINGS



## STEP 02

### Attach the Battery Cover

Insert the tabs on one side of the Battery Cover [39B] into the two holes on the Battery Box [39A], as shown in FIG.1 (right) and then lower the other side of the Battery Cover down over the Battery Box.

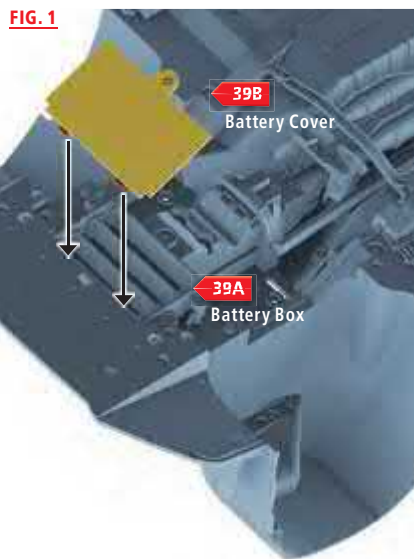
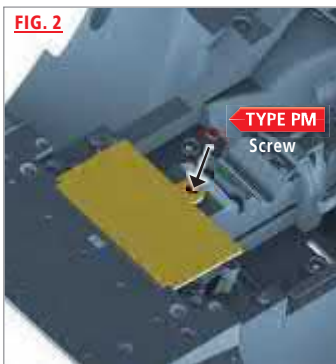

Secure the Battery Cover [39B] to the Battery Box [39A] with a TYPE PM screw, as shown in FIG.2 (left).

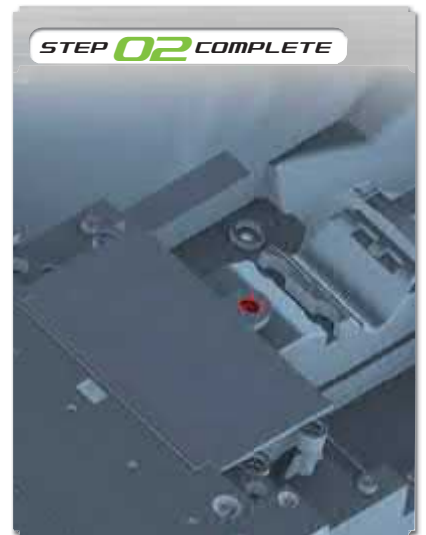



## STEP 03 Attach the ON/OFF Switch with Cable & Switch Holder

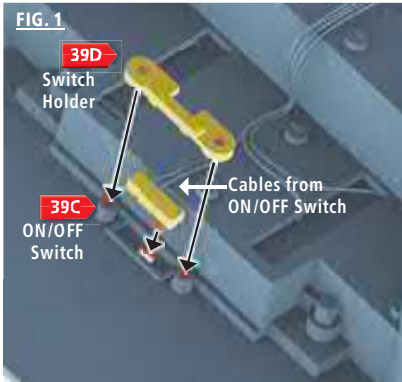

Turn the Chassis over and place the ON/OFF Switch with Cable [39C] onto the Front Chassis [32A], as indicated in FIG.1. Now, place the Switch Holder [39D] over the ON/OFF Switch, so that it will hold in place.

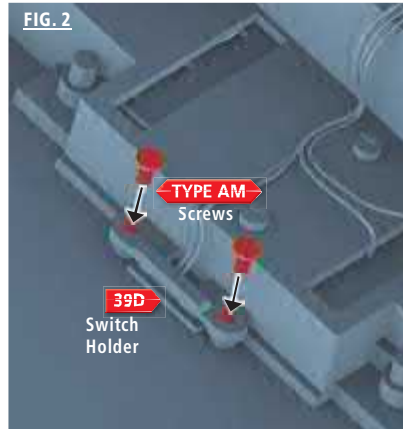

Secure the Switch Holder [39D] to the Front Chassis [32A] with two TYPE AM screws in the holes shown in FIG.2 (above).

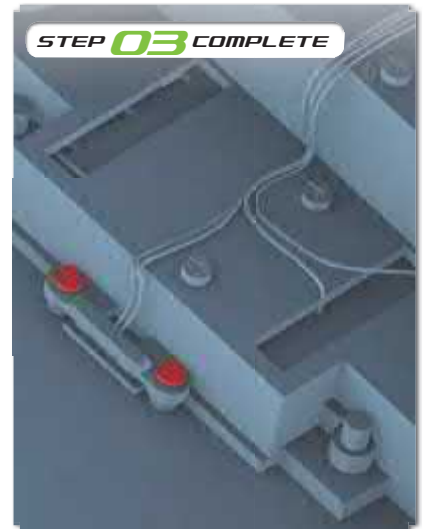

## STEP 04 Attach the ON/OFF Switch with Cable to the Battery Box Cables

Insert the plastic Connector on the end of the Battery Box & Cables [39A] into the plastic Receiver on the end of the ON/OFF Switch with Cable [39C], as shown in the illustration below. It just clicks in place.

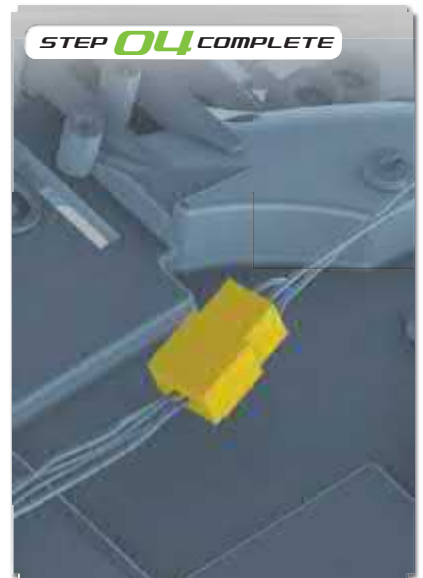
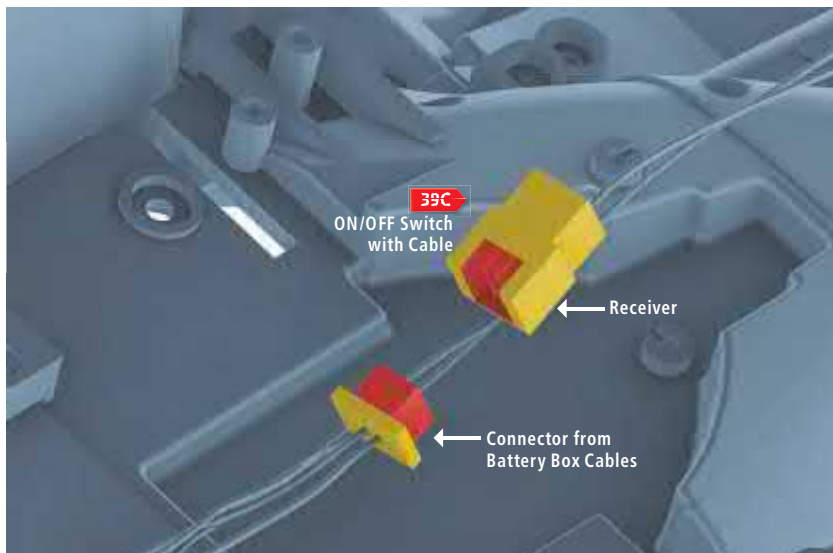

## STEP 05

### Attach the Cable Holders

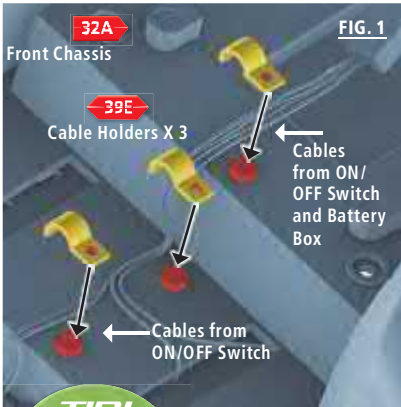

Place the Cable Holders [39E] on the Front Chassis [32A], as shown in FIG.1 (left). The first Cable Holder holds just the ON/OFF Switch Cable [39C], while the next two Cable Holders hold the Cables from the ON/OFF Switch and the Cables from the Battery Box [39A] which you have already fed through from the other side of the Chassis.

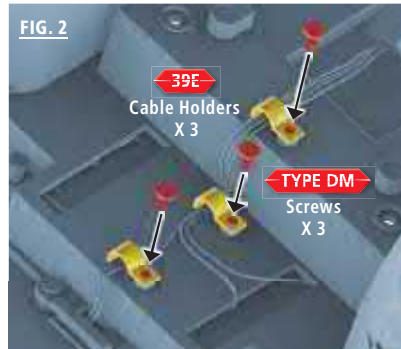

#### TIP!

The Switch Cable Holders are identical, so it doesn't matter which position you place them in.

Secure each Cable Holder [39E] to the Front Chassis [32A] with a TYPE DM screw, as shown in FIG.2 (right).

## Complete!

### The Battery Components

#### TIP!

The Connector at the other end of the ON/OFF Switch with Cable will attach to another part in a later magazine.

#### TIP!

The Battery Cover can be unscrewed so that you can add batteries later.



This is how the Chassis should look once you have attached the Battery Compartment.



## FRONT LEFT WHEEL

Now you will fit the Front Left Tire to the Front Left Wheel of your model NISSAN GT-R (R35).

### PARTS LOCATION



### PARTS LIST

#### PART IDENTIFICATION LIST

PART No.	NAME	QUANTITY	MATERIAL
40A	Wheel	1	ZINC
40B	Wheel Cap	1	ABS
40C	Front Tire	1	PVC
Screws	Type CM 0.1 x 0.2" [2.6 x 6 mm]	1 [+1 spare]	Metal



40A



40B



40C

TYPE CM

## STEP 01

### Put the Front Left Tire in a container of hot water

As the Front Left Tire [40C] needs to fit tightly to the Wheel, it can be difficult to push it on. To make it easier, place the Tire in a container of hot water and leave to soak for one minute.

#### COLOR KEY

- PART BEING FITTED
- PART BEING FITTED TO
- FIXINGS



#### TIP!

Ideally, the water should be at 36°C [96.8°F] to make the Tire softer.

## STEP 02

### Fit the Front Left Tire to the Wheel

Now, take the Front Left Tire [40C], which should be softer and easier to manipulate, out of the water and ease it slowly over the Wheel [40A]. Make sure that the more widely spaced tread pattern (see image) faces the outside of the Wheel.



## DUNLOP SP SPORT MAXX GT 600 DSST CTT

Nissan worked with Dunlop to develop a tire, exclusive to the R35 GT-R, that could maximize the electronically-controlled all-wheel drive system fitted to the car.

Tested at Nürburgring, the Dunlop tires feature race-inspired technologies, such as a high-grip, silica-reinforced tread compound and a solid center rib to help enhance steering response and driver feedback.

An asymmetric tread pattern was also developed to provide a balanced performance in wet and dry conditions and circumferential grooves help to evacuate water for enhanced wet traction.



### *Complete!*

#### The Front Left Wheel

This combined Front Wheel and Tire will be joined to the Front Suspension parts later, so make sure that you keep this assembly, the Wheel Cap and Screw safe until they are needed.



# THE FRONT LEFT SUSPENSION

Let's begin building the Front Left Suspension of your model NISSAN GT-R (R35).

## PARTS LOCATION

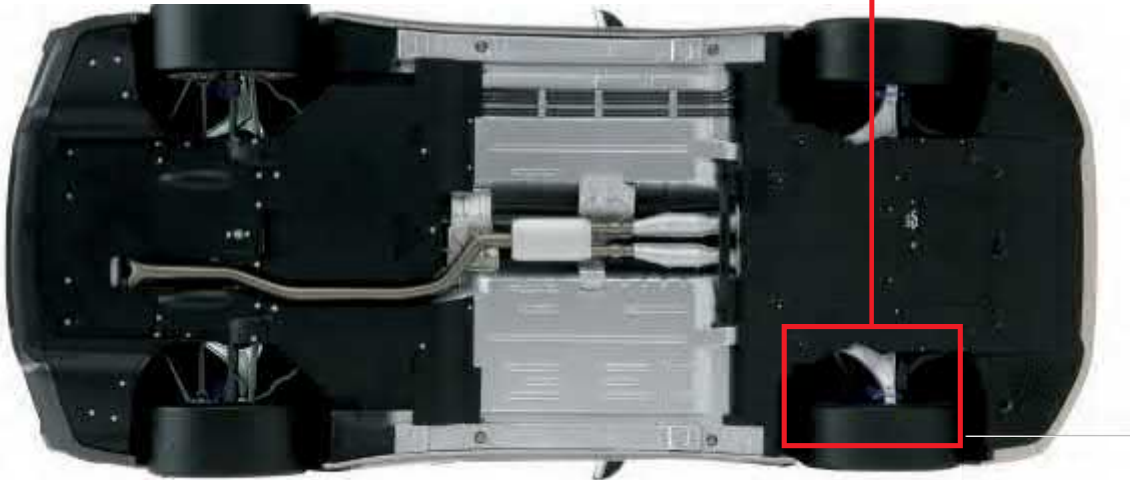

## PARTS LIST

### PART IDENTIFICATION LIST

PART No.	NAME	QUANTITY	MATERIAL
41A	Left Arm Join	1	Zinc
41B	Left Lower Swing Arm	1	Zinc
41C	Hinge A	1	Zinc
41D	Hinge B	1	Zinc
Screws	Type DM 0.08 x 0.12" [2 x 3 mm]	1 [+1 spare]	Metal



41A

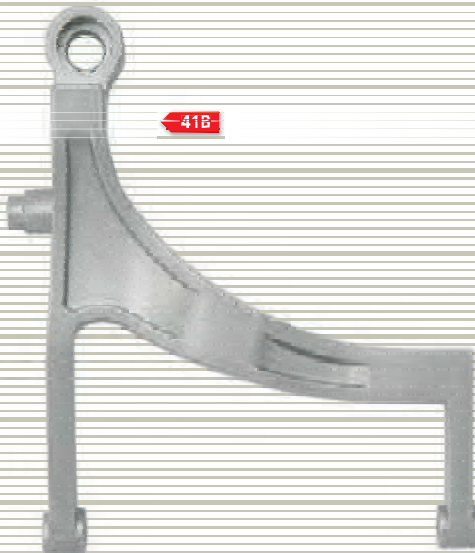

41B



TYPE DM



41C



41D

# HOW TO BUILD

## STEP 01

### Attach the Left Arm Join to the Left Lower Swing Arm

Place the Left Arm Join [41A] onto the Left Lower Swing Arm [41B], as indicated in the illustration. The smaller of the two circular

parts of the Left Arm Join attaches to the Left Lower Swing Arm. Next, use a **TYPE DM** screw to secure it in place from above.

#### COLOR KEY

- PART BEING FITTED
- PART BEING FITTED TO
- FIXINGS



#### TIP!

The Left Arm Join should still be able to move freely once it is screwed in place.

## Complete!

### The Front Left Suspension

This is just the first stage of building the Front Left Suspension and more components will be added over the next few pages.



#### TIP!

Keep Hinge A and Hinge B safe, as they will be used later.



# THE FRONT LEFT SUSPENSION

Continue building the Front Left Suspension of your model  
NISSAN GT-R (R35).

## PARTS LOCATION

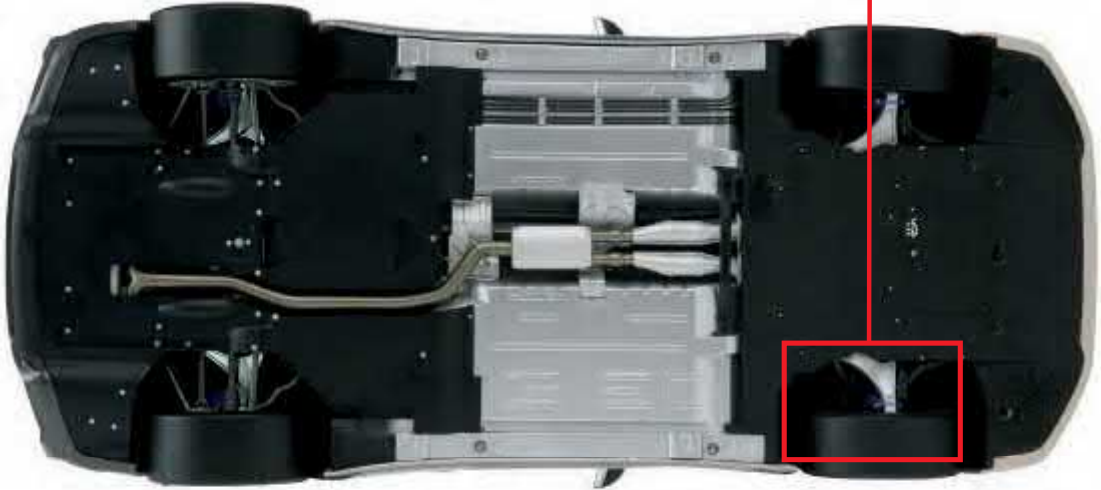

## PARTS LIST

### PART IDENTIFICATION LIST

PART No.	NAME	QUANTITY	MATERIAL
42A	Coil Spring	1	Metal hardware
42B	Stroke	1	Zinc
42C	Upper Mount	1	Zinc
42D	Knuckle Base	1	Zinc
Screws	Type NM 0.09 x 0.16" [2.3 mm x 4mm]	1 [+1 spare]	Metal
Screws	Type FM 0.08 x 0.5" [2 x 13mm]	1 [+1 spare] + Nuts	Metal



TYPE FM



TYPE FM NUT



TYPE NM



42A



42B



42C



42D



## STEP 01 Combine the Shock Absorber parts

Insert the Upper Mount [42C] inside the Coil Spring [42A]. It does not matter which end of the Coil Spring you push the Upper Mount into.

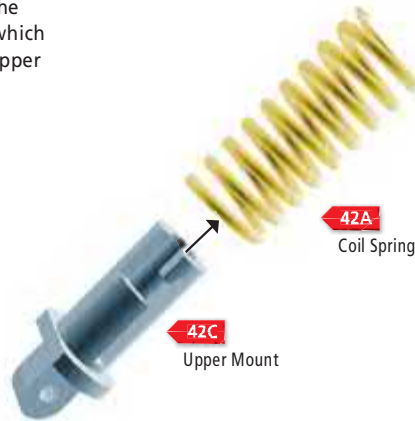

**COLOR KEY**  
■ PART BEING FITTED  
■ PART BEING FITTED TO  
■ FIXINGS



## STEP 02 Complete the Shock Absorber

Slide the Stroke [42B] into the other end of the Coil Spring [42A]. Push the Upper Mount and the Stroke firmly together, so that the Coil Spring compresses enough for you to fit the peg on the end of the Stroke inside the slot on the Upper Mount.

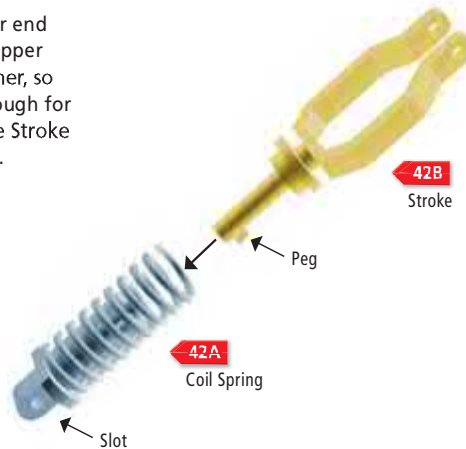

## STEP 03 Attach the combined Shock Absorber to the Left Lower Swing Arm

Slot the combined Shock Absorber onto the Left Lower Swing Arm [41B] you assembled on page 28 and then slide a TYPE FM screw through the holes indicated in the illustration and secure the parts together with a nut from the other side.

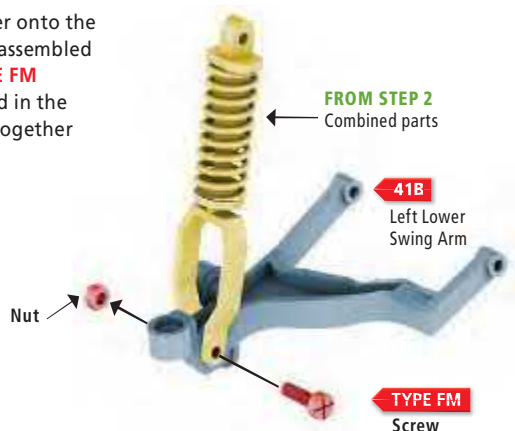

## STEP 04

### Attach the Knuckle Base to the Left Lower Swing Arm

Slot the strut on the Knuckle Base [42D] into the hole on Left Lower Swing Arm [41B], as shown in the illustration and then use a **TYPE NM** screw from above to secure the parts together. Don't be concerned that the Knuckle Base is a bit loose on the Left Lower Swing Arm, as it should be able to twist slightly from side to side.

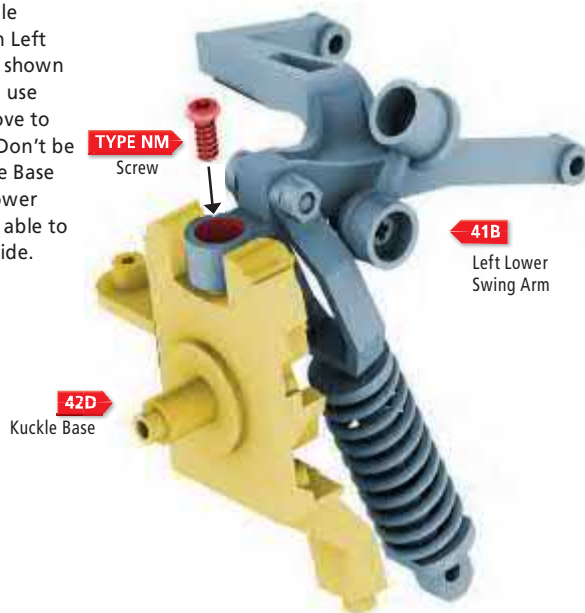

## Complete!

### The Front Left Suspension

This completes the Front Left Suspension for now, but more parts will be added to it in the next magazine.

View A



View B



## THE FRONT LEFT SUSPENSION

In this magazine you will continue building the Front Left Suspension of your model NISSAN GT-R (R35).

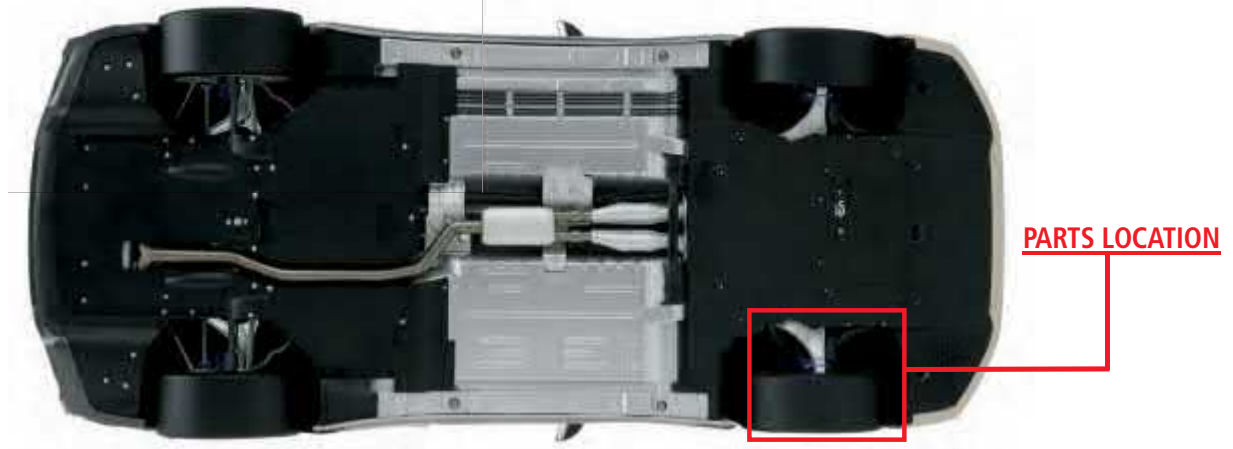

### PARTS LIST



43A



43B



43C

### PART IDENTIFICATION LIST

PART No.	NAME	QUANTITY	MATERIAL
43A	Upper Swing Arm Base	1	Zinc
43B	Upper Swing Arm	1	Zinc
43C	Hinge A	1	Zinc
Screws	Type EM 0.08 x 0.4" [2 x 10mm]	2 [+3 spare]	Metal + Nuts
Screws	Type FM 0.08 x 0.5" [2 x 13mm]	1 [+3 spare]	Metal + Nuts
Screws	Type HM 0.09 x 0.16" [2.3 x 4mm]	2 [+1 spare]	Metal
Screws	Type NM 0.09 x 0.16" [2.3 x 4mm]	1 [+1 spare]	Metal



TYPE EM



TYPE FM



TYPE HM



TYPE NM

## STEP 01

### Assemble the Upper Swing Arm & Base

Slot the Upper Swing Arm [43B] into the Upper Swing Arm Base [43A], as shown in FIG.1. The fit is quite tight, so it may require a little force to make all the holes line up.

FIG. 1

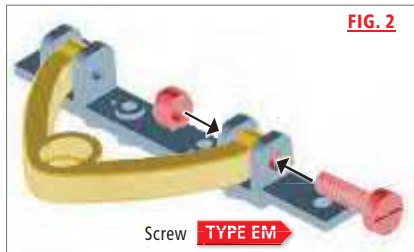
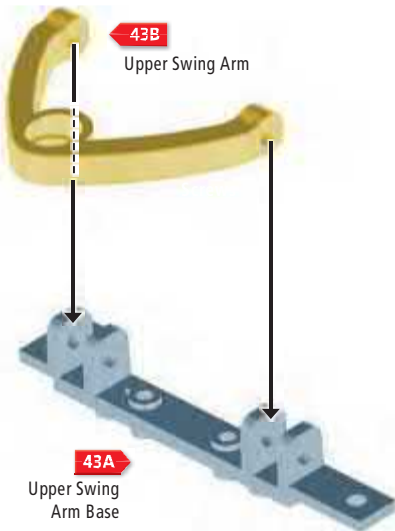

Take a TYPE EM screw and push it through the holes, as shown in FIG.2 (above), before securing the parts together from the other side with a nut.



Take another TYPE EM screw and push it through the holes on the opposite side, as shown in FIG.3 (above), before securing the parts together with a nut.

#### COLOR KEY

- PART BEING FITTED
- PART BEING FITTED TO
- FIXINGS



## STEP 02

### Attach Hinge A to the Upper Swing Arm Base

Place Hinge A [43C] onto the Upper Swing Arm Base [43A], as indicated in the illustration below, making sure that it is the correct way around. Now, use two TYPE HM screws from above to secure the parts together.

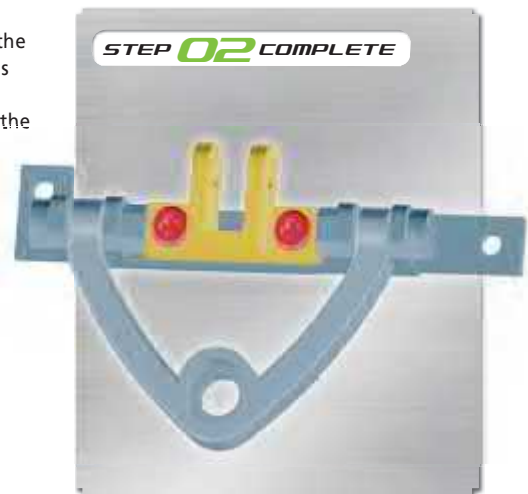
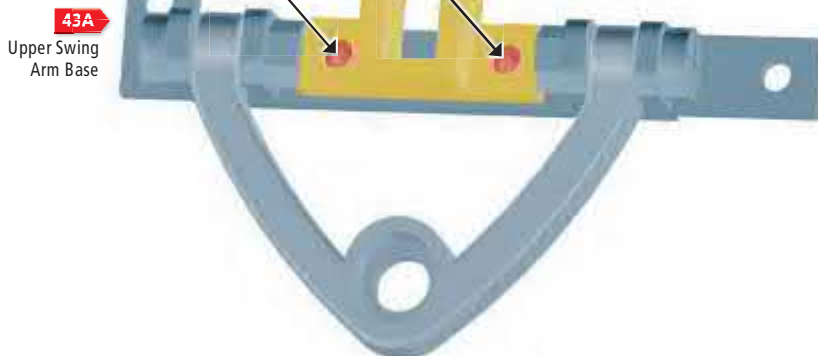

## STEP 03 Attach the Upper Swing Arm Parts

Attach the Upper Swing Arm parts you have just assembled to the parts you built in the previous magazine by sliding Hinge A [43C] over the top of the Stroke [42B], so that the holes line up as shown in the illustration. Now, push a **TYPE FM** screw through the holes and use a nut from the other side to secure the parts together.

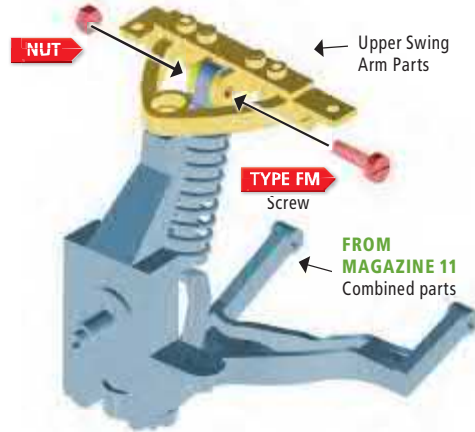

## STEP 04 Secure the Upper Swing Arm Parts

Push the hole on the Upper Swing Arm [43B] over the end of the Knuckle Base [42D], as indicated in the illustration. Now, use a **TYPE NM** screw from above to secure the parts together. Make sure that the struts on the Upper Swing Arm Base [43A] are at the top, as shown in the illustration.

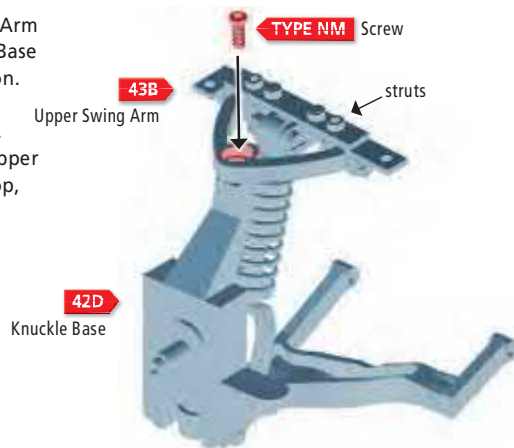

## Complete!

### Front Left Suspension

This completes the third stage of assembling the Front Left Suspension of your NISSAN GT-R (R35) model and this is how it should now look.



# FRONT LEFT BRAKE SYSTEM

Now you will assemble the Front Left Brake Disc and add the Brake Caliper to the Front Left Suspension of your model.

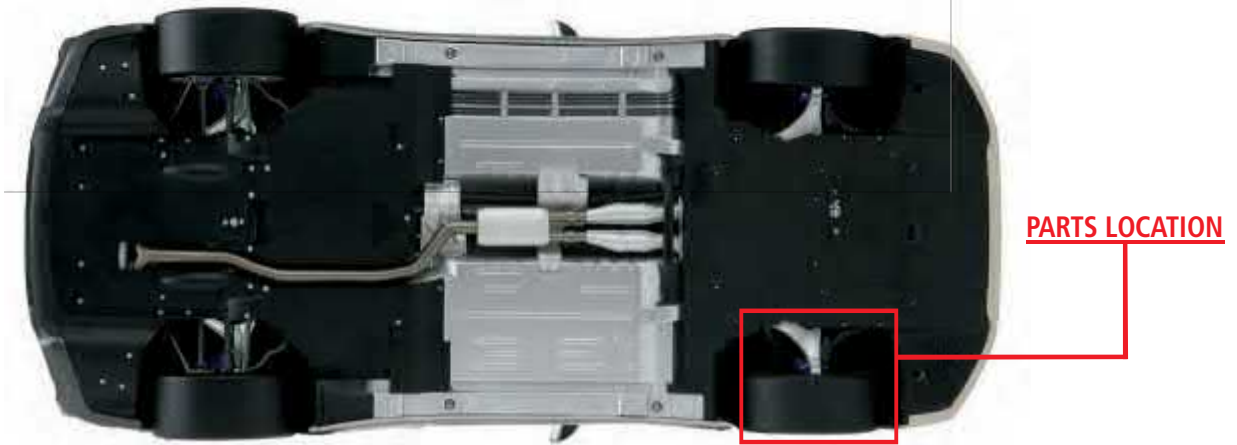

**PARTS LOCATION**

## PARTS LIST

### PART IDENTIFICATION LIST

PART No.	NAME	QUANTITY	MATERIAL
44A	Brake Caliper	1	Zinc
44B	Brake Disc Plate	1	Photo Etch
44C	Brake Disc Plate Hub	1	ABS
44D	Brake Disc Base	1	ABS
Screws	Type MP 0.06 x 0.16" [1.7 x 4mm]	2 [+1 spare]	Metal
Screws	Type HM 0.09 x 0.16" [2.3 x 4mm]	2 [+1 spare]	Metal



44A



44B



44C



44D



TYPE MP



TYPE HM

## STEP 01

### Add the Brake Disc Plate to the Brake Disc Base

Place the Brake Disc Plate [44B] onto the side of the Brake Disc Base [44D] that has the vanes (see illustration). Now, turn the Brake Disc Plate until the holes for the screws line up with those on the Brake Disc Base, but do not screw them together yet.

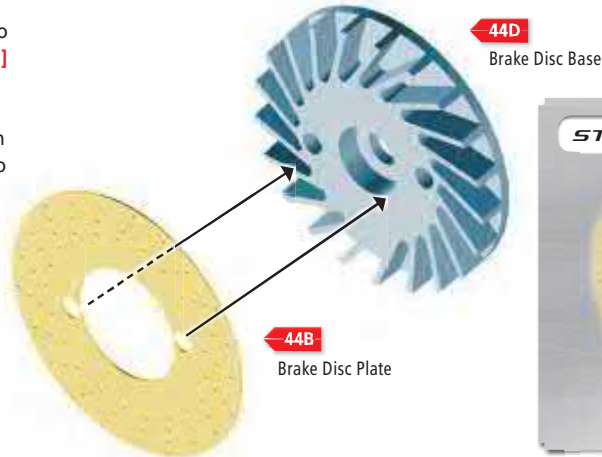

## STEP 02

### Add the Brake Disc Plate Hub

Take the Brake Disc Plate Hub [44C] and push its pegs through the holes on the Brake Disc Plate [44B] and Brake Disc Base [44D], holding it all together with your fingers.

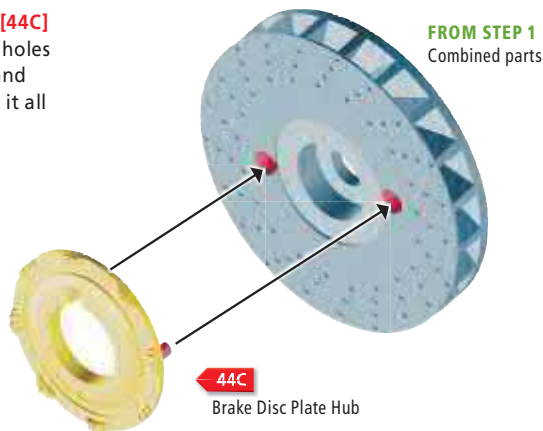

## STEP 03

### Secure the Brake Disc parts together

On the opposite side of the Brake Disc Base [44D], use two TYPE MP screws in the holes indicated in the illustration to secure all the parts together. Now put the assembled Brake Disc in a safe place, as you will add it to your model at a later stage.

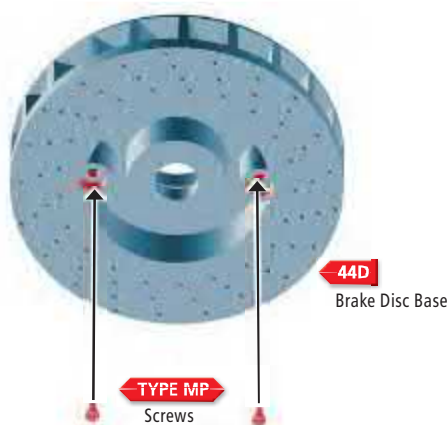

## STEP 04

### Attach the Brake Caliper

Take the combined parts of the Front Left Suspension that you completed on page 26 and secure the legs of the Brake Caliper [44A] onto the Knuckle Base [42D] with two TYPE HM Screws, as shown in the illustration.

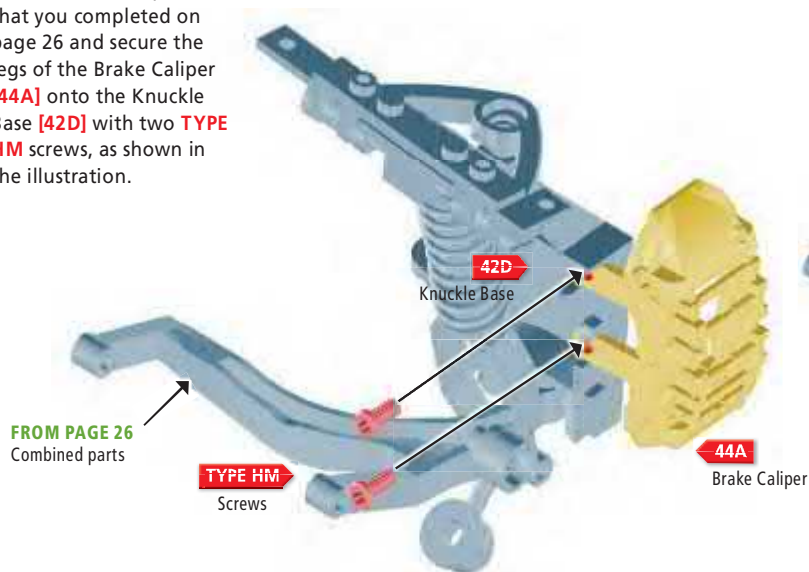

## Complete!

### Front Left Suspension

Here is a view of the combined parts of the Front Left Suspension, so that you can see how it should look once you have added the Brake Caliper.

#### TIP!

Keep the combined Brake Disc parts safe, as they will be fitted in a later magazine.





## THE FRONT HALF SHAFTS

Let's continue building the Front Left Suspension of your model NISSAN GT-R (R35) by part-assembling the Half Shafts.

### PARTS LOCATION

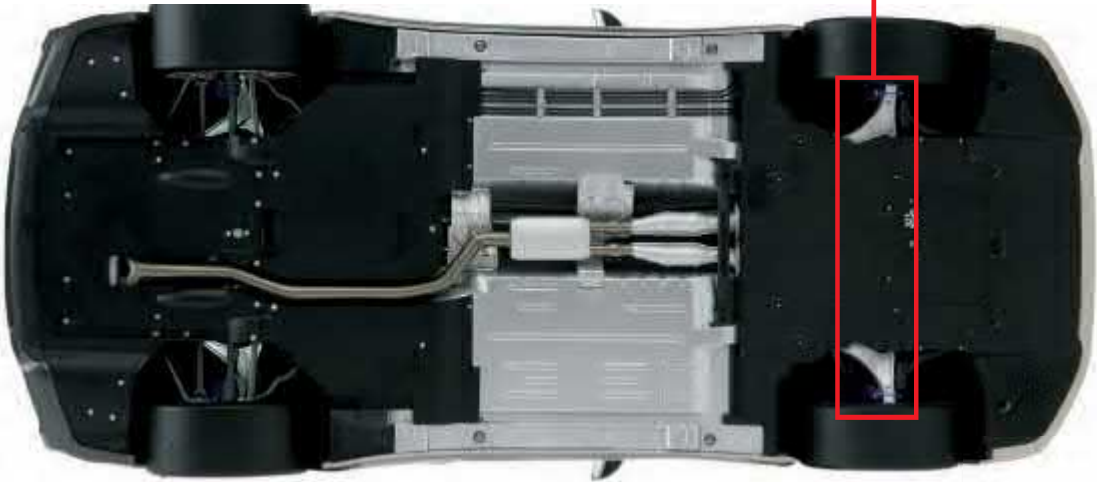

### PARTS LIST

**TIP!**  
Keep the Left Front Half Shaft safe, as it will be fitted in a later magazine.

#### PART IDENTIFICATION LIST

PART No.	NAME	QUANTITY	MATERIAL
45A	Left Front Half Shaft	1	ABS
45B	Right Front Half Shaft	1	ABS
45C	Middle Front Half Shaft	1	ABS
Screws	Type HP 0.09 x 0.16" [2.3 x 4 mm]	1 [+1 spare]	Metal



45A



45B



45C

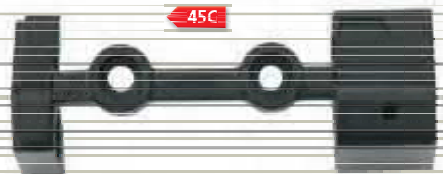

## STEP 01

### Combine the Right & Middle Front Half Shafts

#### COLOR KEY

- PART BEING FITTED
- PART BEING FITTED TO
- FIXINGS

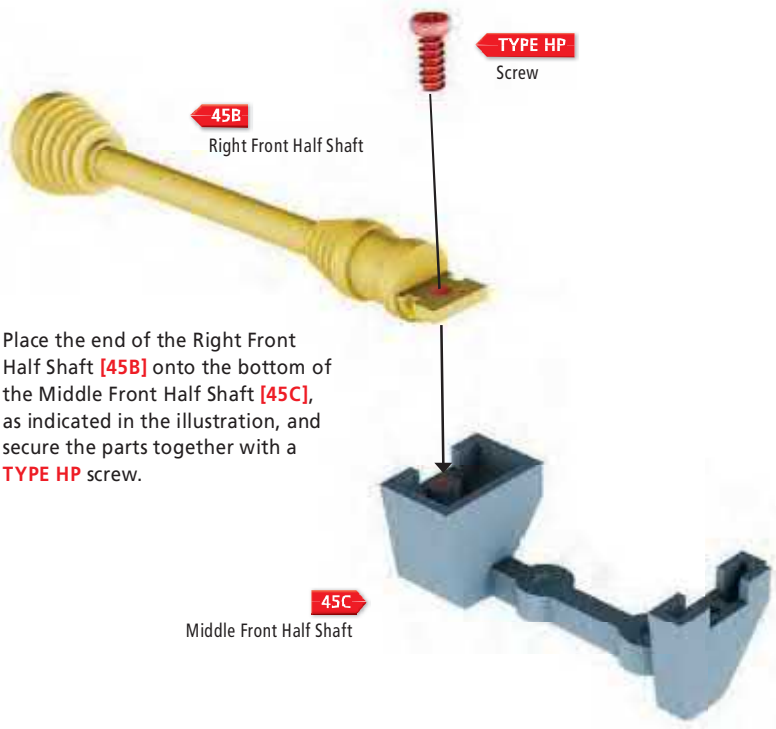

Place the end of the Right Front Half Shaft [45B] onto the bottom of the Middle Front Half Shaft [45C], as indicated in the illustration, and secure the parts together with a TYPE HP screw.



## Complete!

### The Front Half Shafts

This is as far as you can assemble the Front Half Shafts for now. The rest will be completed in a later magazine, when you receive the Front Chassis Frame.

#### TIP!

The Front Half Shafts will attach to the Front Chassis Frame in a later magazine.



## THE FRONT RIGHT SUSPENSION

Now you will begin building the Front Right Suspension of your model NISSAN GT-R (R35).

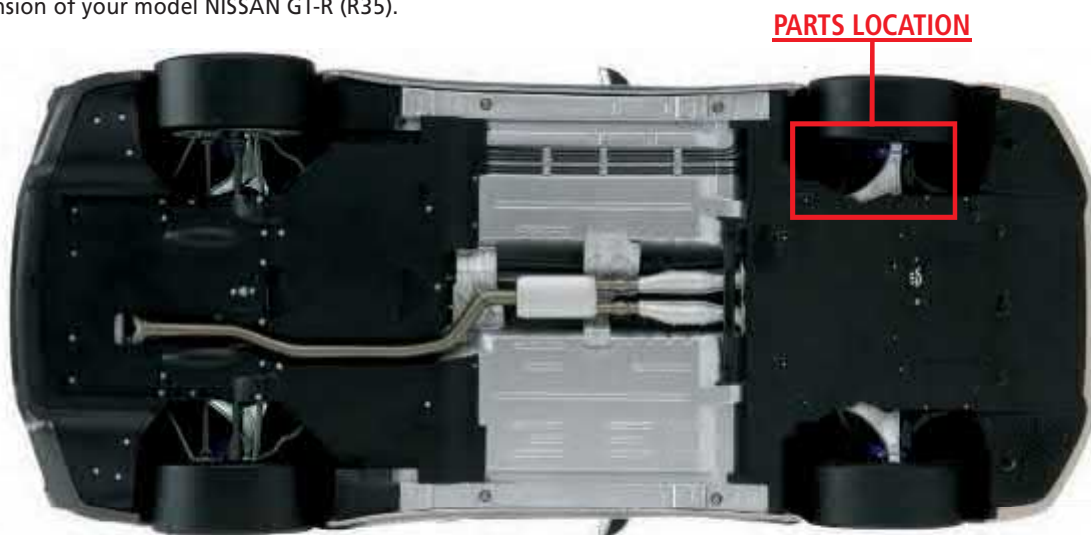

### PARTS LIST

#### PART IDENTIFICATION LIST

PART No.	NAME	QUANTITY	MATERIAL
46A	Right Arm Join	1	Zinc
46B	Right Lower Swing Arm 1	1	Zinc
46C	Hinge A	1	Zinc
46D	Hinge B	1	Zinc
Screws	Type DM 0.08 x 0.12" [2 x 3 mm]	1 [+1 spare]	Metal



46A

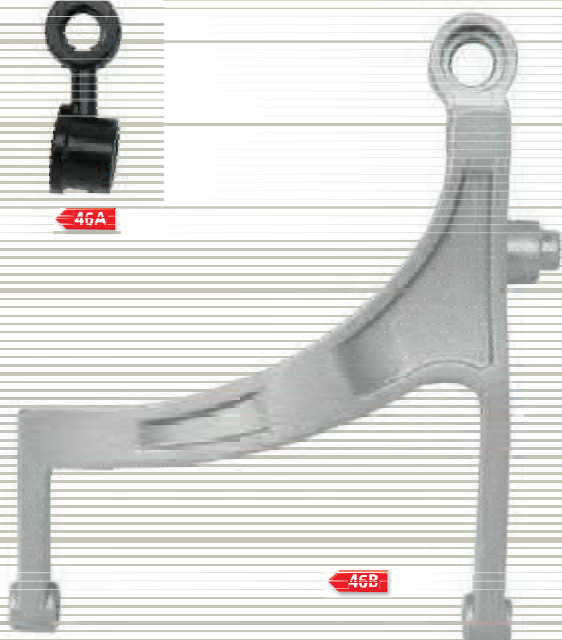

46B



TYPE DM



46C



46D

## STEP 01

### Attach the Right Arm Join

Place the Right Arm Join [46A] onto the Right Lower Swing Arm [46B], as indicated in the illustration – the smaller of the two circular parts of the Right Arm Join fits onto the Right Lower Swing Arm. Next, use a TYPE DM screw from above to secure it in place.

#### COLOR KEY

- PART BEING FITTED
- PART BEING FITTED TO
- FIXINGS



## Complete!

### The Right Arm Join

This is just the first stage in building the Front Right Suspension and many more components will be included with the next few magazines. So keep all of your parts in a safe place for now.



## THE FRONT RIGHT SUSPENSION

In this magazine you will continue building the Front Right Suspension of your NISSAN GT-R (R35) model.

### PARTS LOCATION

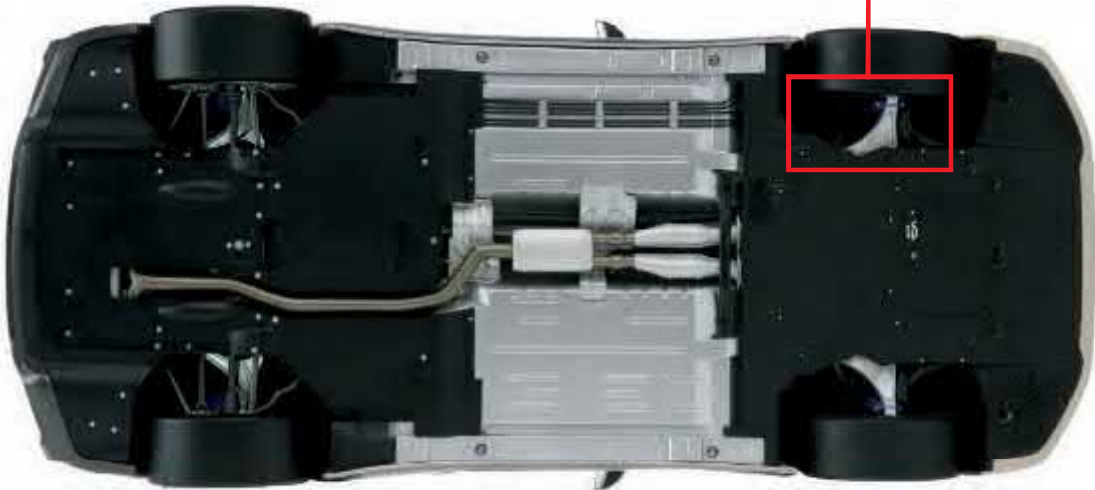

### PARTS LIST

#### PART IDENTIFICATION LIST

PART No.	NAME	QUANTITY	MATERIAL
47A	Coil Spring	1	Metal
47B	Stroke	1	Zinc
47C	Upper Mount	1	Zinc
47D	Knuckle Base	1	Zinc
Screws	Type NM 0.09 x 0.16" [2.3 x 4mm]	1 [+1 spare]	Metal
Screws	Type FM 0.08 x 0.5" [2 x 13mm]	1 [+1 spare]	Metal



## STEP 01

### Combine the Shock Absorber parts

Insert the Upper Mount [47C] inside the Coil Spring [47A]. It does not matter which end of the Coil Spring you insert the Upper Mount into.

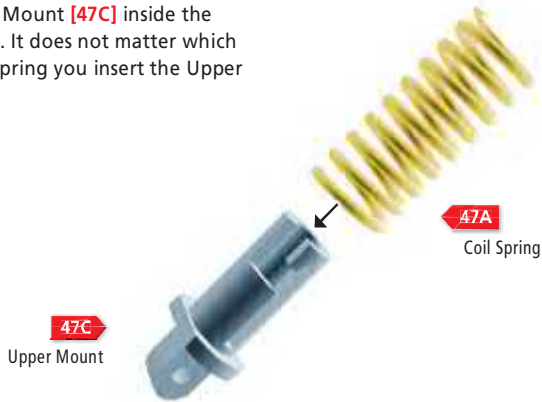

#### COLOR KEY

- PART BEING FITTED
- PART BEING FITTED TO
- FIXINGS

### STEP 01 COMPLETE



## STEP 02

### Complete the Shock Absorber

Slide the Stroke [47B] into the other end of the Coil Spring [47A]. Push the Upper Mount and the Stroke firmly together so that the Coil Spring compresses enough for you to fit the peg on the end of the Stroke inside the slot on the Upper Mount.

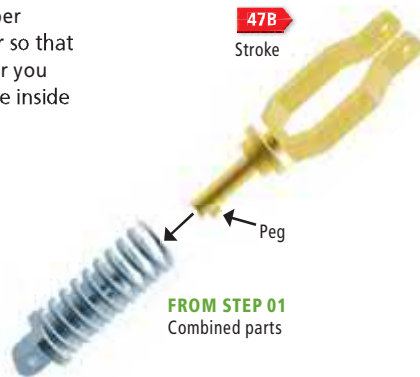

### STEP 02 COMPLETE



## STEP 03

### Attach the combined Shock Absorber to the Right Lower Swing Arm

Slot the combined Shock Absorber onto the Right Lower Swing Arm [46B] that came with the previous magazine. Then slide a TYPE FM screw through the holes indicated in the illustration and secure the parts together with a nut from the other side.



### STEP 03 COMPLETE



## STEP 04

### Attach the Knuckle Base to the Right Lower Swing Arm

Slot the strut on the Knuckle Base [47D] into the hole on Right Lower Swing Arm [46B] as shown in the illustration and then use a **TYPE NM** screw from above to secure the parts together. Don't worry that the Knuckle Base is a bit loose on the Right Lower Swing Arm, as it should be able to twist slightly from side to side.



## Complete!

### Front Right Suspension

This completes the second stage of assembling the Front Right Suspension and more parts will be added over the next few pages.

View A



### TIP!

Both the combined Shock Absorber and Knuckle Base should be able to move slightly on the Right Lower Swing Arm.

View B



# THE FRONT RIGHT SUSPENSION

Continue building your model's Front Right Suspension.

## PARTS LOCATION

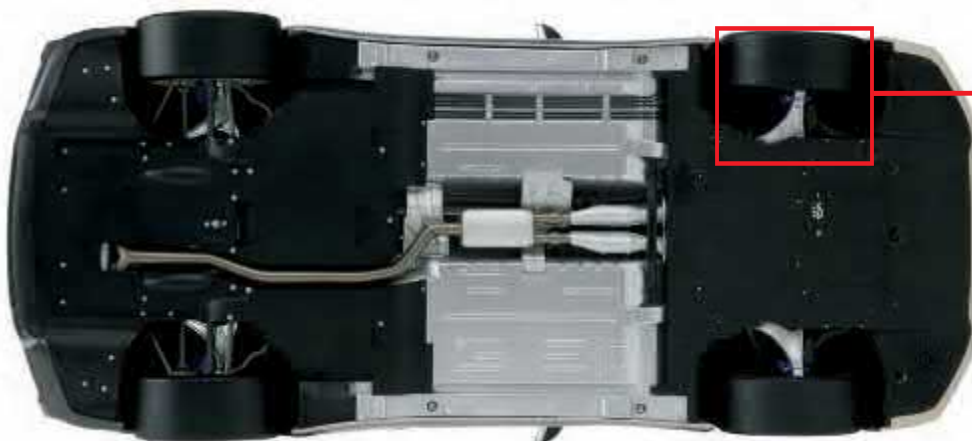

## PARTS LIST

### PART IDENTIFICATION LIST

PART No.	NAME	QUANTITY	MATERIAL
48A	Upper Swing Arm Base	1	Zinc
48B	Upper Swing Arm	1	Zinc
48C	Hinge A	1	Zinc
Screws	Type EM 0.08 x 0.4" [2 x 10mm]	2 [+3 spares]	Metal + nuts
Screws	Type FM 0.08 x 0.5" [2 x 13mm]	1 [+3 spares]	Metal
Screws	Type HM 0.09 x 0.16" [2.3 x 4mm]	2 [+1 spare]	Metal + nuts
Screws	Type NM 0.09 x 0.16" [2.3 x 4mm]	1 [+1 spare]	Metal



48A



48B



48C



TYPE EM

NUT



TYPE FM

NUT



TYPE HM

TYPE NM



## STEP 01 Assemble the Upper Swing Arm & Base

Slot the Upper Swing Arm [48B] into the Upper Swing Arm Base [48A], as shown in FIG.1. The fit is quite tight, so it may require a little force to make all the holes line up.

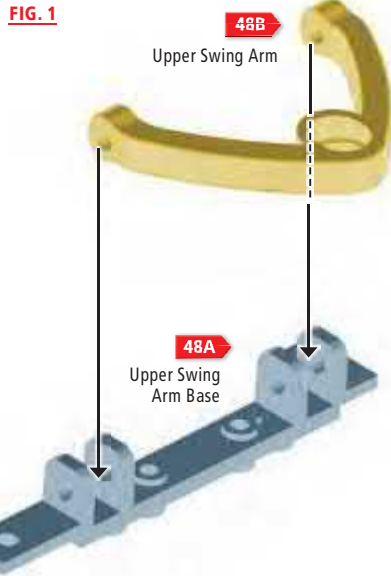
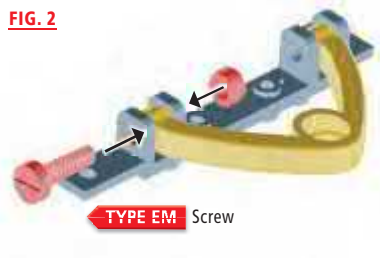

FIG. 2



Take a **TYPE EM** screw and push it through the holes, as shown in FIG.2 (above), before securing the parts together from the other side with a nut.

FIG. 3



Take another **TYPE EM** screw and push it through the holes on the opposite side, as shown in FIG.3 (above), before securing the parts together with a nut.

### COLOR KEY

- PART BEING FITTED
- PART BEING FITTED TO
- FIXINGS



## STEP 02 Attach Hinge A to the Upper Swing Arm Base

Place Hinge A [48C] onto the Upper Swing Arm Base [48A], as indicated in the illustration below, making sure that it is the correct way around. Now, use two **TYPE HM** screws from above to secure the parts together.

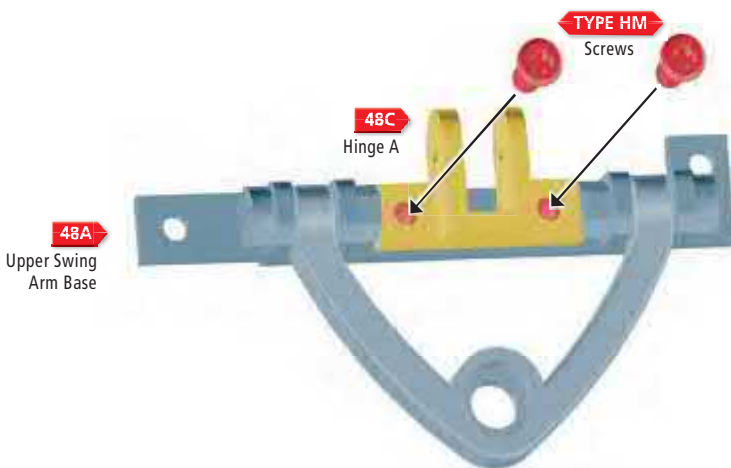

## STEP 03 Attach the Upper Swing Arm parts

Attach the Upper Swing Arm parts you have just built to the parts you assembled on page 22 by sliding Hinge A [48C] over the top of the Upper Mount [47C], so that the holes line up as shown in the illustration. Now, push a TYPE FM screw through the holes and use a nut from the other side to secure the parts together.

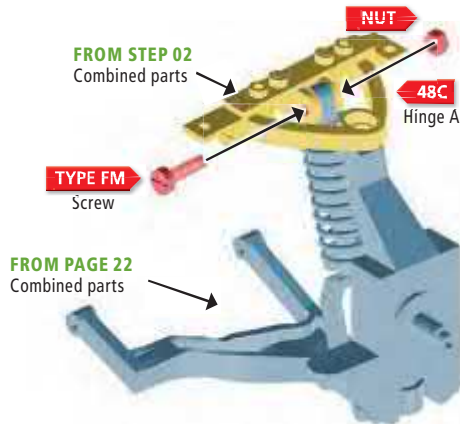

## STEP 04 Secure the Upper Swing Arm parts

Push the hole in the Upper Swing Arm [48B] over the end of the Knuckle Base [47D], as indicated in the illustration. Now, use a TYPE NM screw from above to secure the parts together. Make sure that the struts on the Upper Swing Arm Base [48A] are at the top, as shown in the illustration.

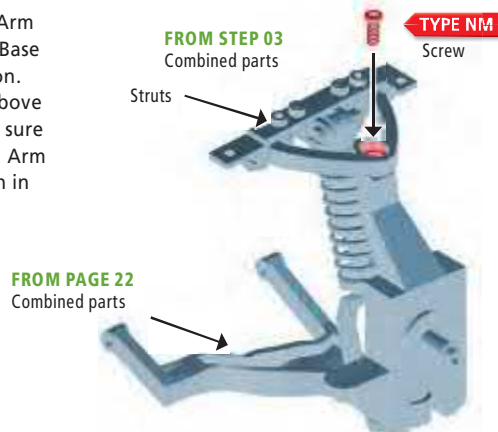

## Complete!

### Front Right Suspension

This completes the third stage of assembling the Front Right Suspension and this is how it should now look.



## FRONT RIGHT BRAKE SYSTEM

Now you will assemble the Front Right Brake Disc and add the Brake Caliper to the Front Left Suspension of your model.

### PARTS LOCATION

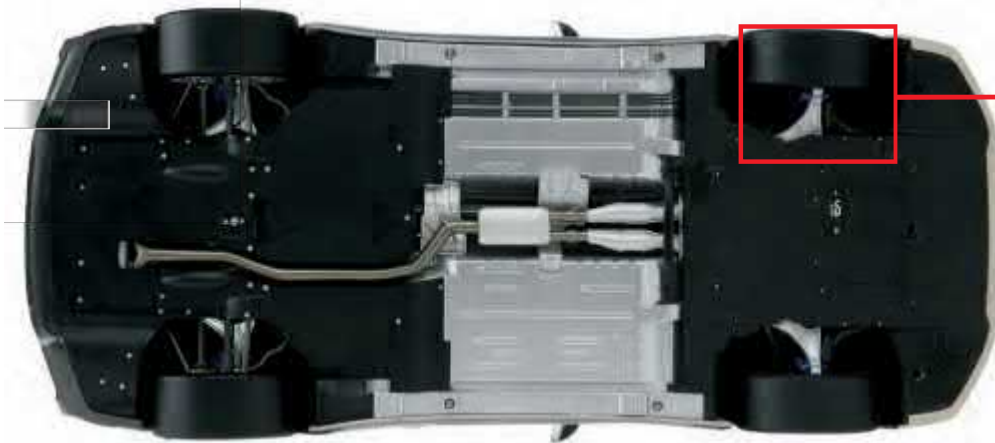

### PARTS LIST

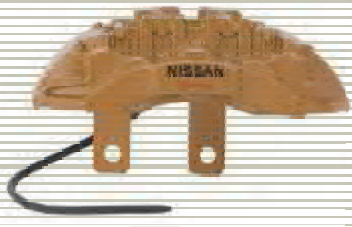

49A



49B



49C



49D

### PART IDENTIFICATION LIST

PART No.	NAME	QUANTITY	MATERIAL
49A	Brake Caliper	1	Zinc
49B	Brake Disc Plate	1	Photo Etch
49C	Brake Disc Plate Hub	1	ABS
49D	Brake Disc Base	1	ABS
Screws	Type MP 0.06 x 0.16" [1.7 x 4mm]	2 [+1 spare]	Metal
Screws	Type HM 0.09 x 0.16" [2.3 x 4mm]	2 [+1 spare]	Metal



TYPE MP



TYPE HM

## STEP 01

### Add the Brake Disc Plate to the Brake Disc Base

Place the Brake Disc Plate [49B] onto the side of the Brake Disc Base [49D] that has the vanes (see illustration). Now, turn the Brake Disc Plate until the holes for the screws line up with those on the Brake Disc Base, but do not screw them together yet.

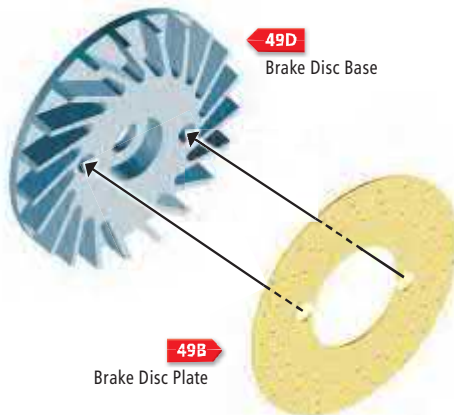

#### COLOR KEY

- PART BEING FITTED
- PART BEING FITTED TO
- FIXINGS



## STEP 02

### Add the Brake Disc Plate Hub

Take the Brake Disc Plate Hub [49C] and push its pegs through the holes on the Brake Disc Plate [49B] and Brake Disc Base [49D], holding it all together with your fingers.

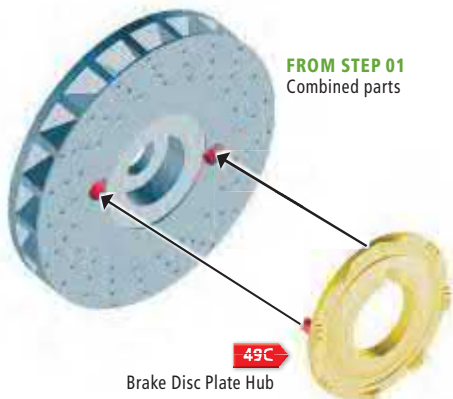

## STEP 03

### Secure the Brake Disc parts together

On the opposite side of the Brake Disc Base [49D], use two TYPE MP screws in the holes indicated in the illustration to secure all the parts together.

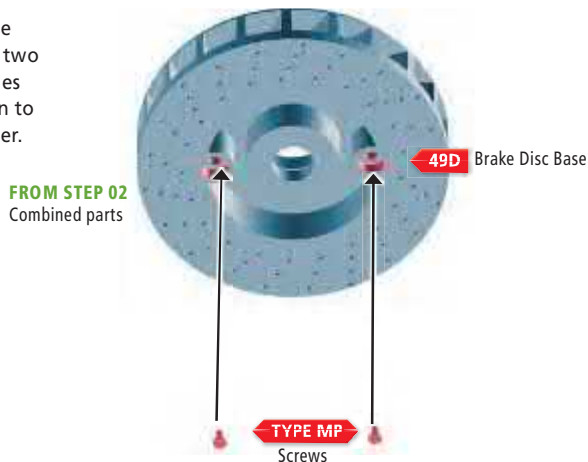

## STEP 04 Attach the Brake Caliper

Take the combined parts of the Front Right Suspension that you built on page 25 and secure the legs of the Brake Caliper [49A] onto the Knuckle Base [47D] with two TYPE HM screws, as shown in the illustration.

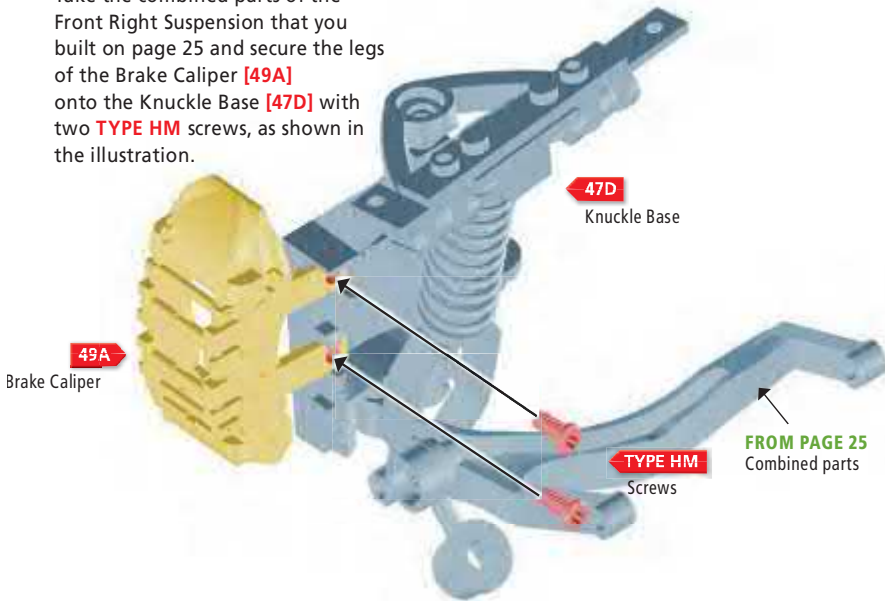

## Complete!

### Front Right Suspension

Here is a photograph of the combined parts of the Front Right Suspension, so that you can see how it should look once you've added the Brake Caliper.



### TIP!

Keep the combined Brake Disc Parts safe, as these will be fitted at a later stage.

# THE STEERING RACK

Now it is time to assemble the Steering Rack and attach it to your NISSAN GT-R (R35) model.

## PARTS LOCATION



## PARTS LIST



TYPE GM

TYPE NM

### PART IDENTIFICATION LIST

PART No.	NAME	QUANTITY	MATERIAL
50A	Steering Shaft	1	Zinc
50B	Steering Rack	1	Zinc
50C	Steering Rack Base	1	ABS
Screws	Type GM 0.08 x 0.16" [2 x 4mm]	2 [+1 spare]	Metal
Screws	Type NM 0.09 x 0.16" [2.3 x 4mm]	2 [+1 spare]	Metal



50A



50B



50C

## STEP 01 Add the Steering Rack Base

Place the Steering Rack Base [50C] onto the top side of the Front Chassis [32A], just behind the Right Wheel Arch. Make sure that the struts on the bottom of the Steering Rack Base go into the holes indicated in the Front Chassis.

### COLOR KEY

- PART BEING FITTED
- PART BEING FITTED TO
- FIXINGS

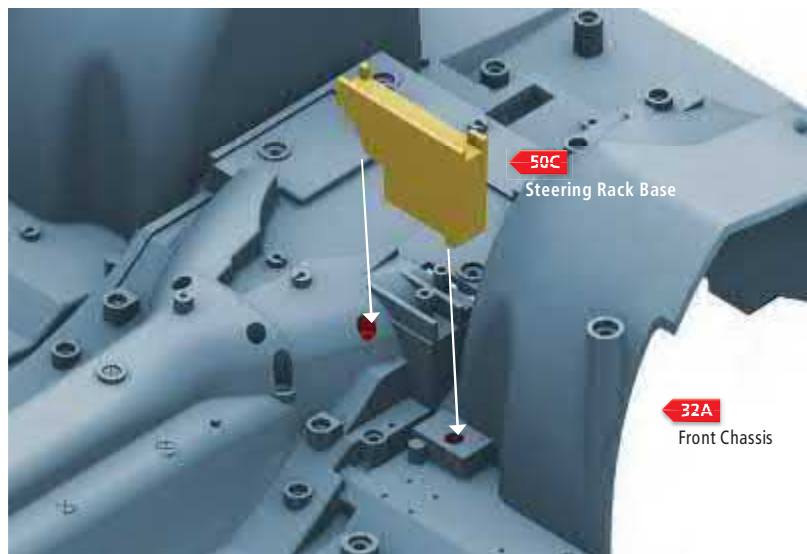

## STEP 02 Secure the Steering Rack Base

Holding the Steering Rack Base [50C] firmly in place, turn the whole Front Chassis over and secure it in place with two TYPE GM screws in the holes indicated in the illustration.



## STEP 03

### Attach the Steering Rack

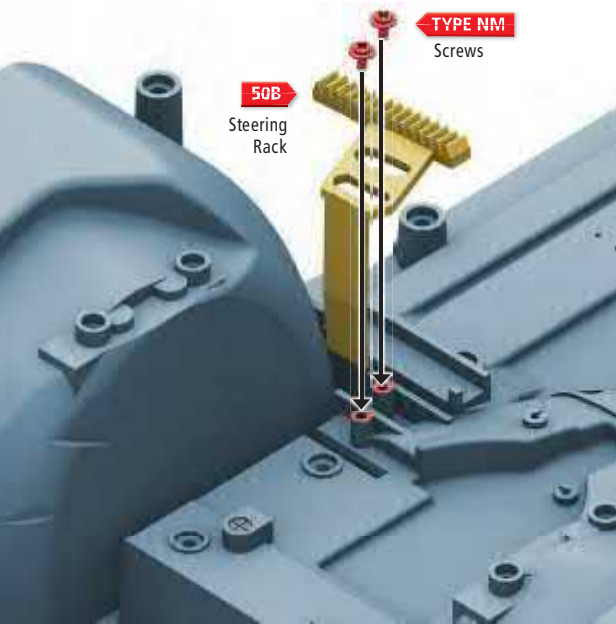

Slot the Steering Rack [50B] into position, as indicated in the illustration (left). The shaft of the Steering Rack should go through the slit in the Front Chassis [32A] while the 'teeth' of the Steering Rack should sit securely within the rails on the top of the Steering Rack Base. Use two TYPE NM screws, as shown in the illustration, to hold the Steering Rack in place. The Steering Rack should be able to slide about an inch (25 mm) from side to side.

## Complete!

### The Steering Rack

Here is how the Steering Rack should look on the top side of the Front Chassis once you have assembled it.

#### TIP!

Keep the Steering Shaft in a safe place, as it will be attached later.

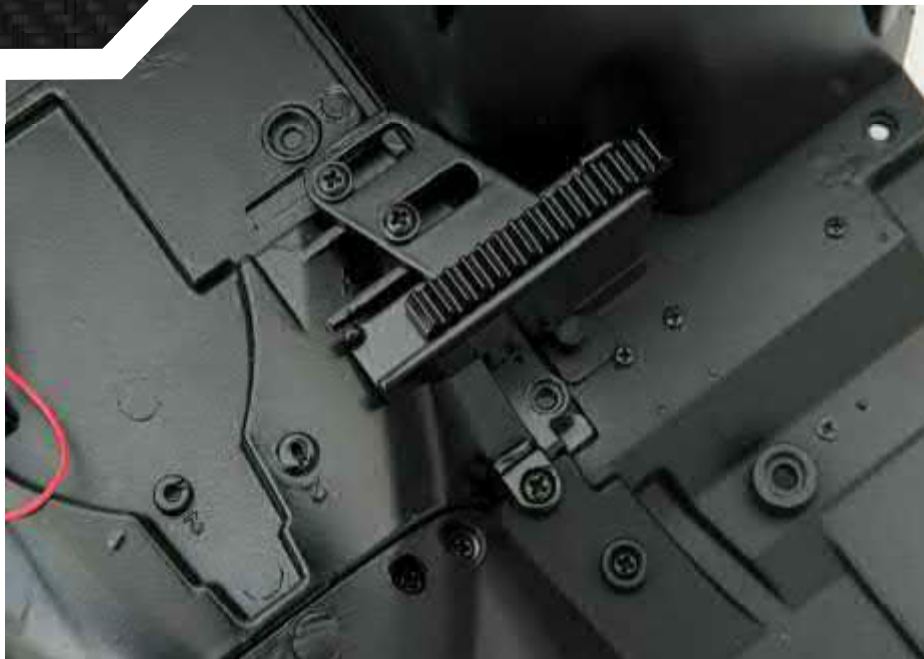



## FRONT RIGHT WHEEL

In this magazine, you will fit the Front Right Tire to the Front Right Wheel of your NISSAN GT-R (R35) model.



PARTS LOCATION

### PARTS LIST

#### PART IDENTIFICATION LIST

PART No.	NAME	QUANTITY	MATERIAL
51A	Front Right Wheel	1	ZINC
51B	Wheel Cap	1	ABS
51C	Front Right Tire	1	PVC
Screws	Type CM 0.1 x 0.2" [2.6 x 6 mm]	1 [+1 spare]	Metal



51A



51B



51C

TYPE CM

## STEP 01

### Place the Front Right Tire in a container of hot water

As the Front Right Tire [51C] needs to fit tightly to the Wheel, it can be difficult to push it on. To make it easier, place the Tire in a container of hot water and leave to soak for one minute.

#### TIP!

Ideally, the water should be at 96.8°F [36°C] to make the Tire softer.

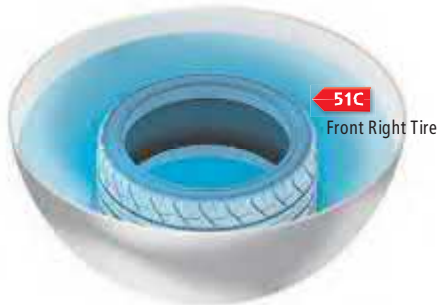

#### COLOR KEY

- PART BEING FITTED
- PART BEING FITTED TO
- FIXINGS

## STEP 02

### Fit the Front Right Tire to the Wheel

After one minute, take the Front Right Tire [51C], which should be softer and easier to manipulate, out of the water and ease it slowly over the Wheel [51A]. Make sure that the more widely spaced tread pattern (see image) faces the outside of the Wheel.



## Complete!

### The Front Right Wheel

The combined Front Right Wheel and Tire will be joined to the Front Suspension parts in a future magazine, so ensure that you keep it, the Wheel Cap and screw in a safe place until then.



## THE FRONT SUSPENSION ARMS

Now you will attach the Left and Right Suspension Arms to the Front Suspension components you have already assembled for your model.

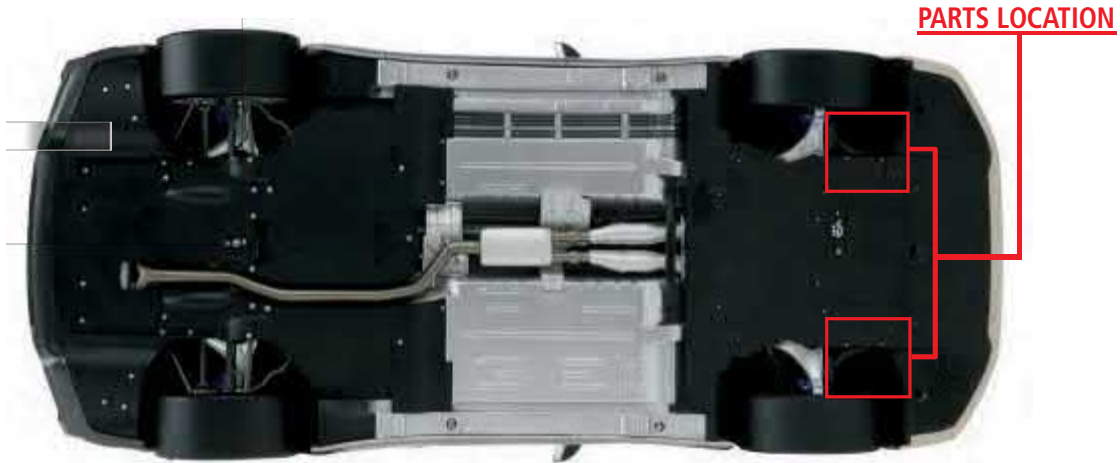

### PARTS LIST

#### PART IDENTIFICATION LIST

PART No.	NAME	QUANTITY	MATERIAL
52A	Left Suspension Arm	1	Zinc
52B	Left Arm Housing	1	Zinc
52C	Right Suspension Arm	1	Zinc
52D	Right Arm Housing	1	Zinc
Screws	Type IM 0.07 x 0.12" [1.7 x 3mm]	2 [+2 spares]	Metal



## STEP 01

### Attach the Left Suspension Arm

#### COLOR KEY

- PART BEING FITTED
- PART BEING FITTED TO
- FIXINGS

Take the combined Left Suspension parts you completed in Magazine 11 and slot the Left Suspension Arm [52A] into the Left Arm Join [41A]. Secure it from the other side with a **TYPE IM** screw, as indicated in the illustration.

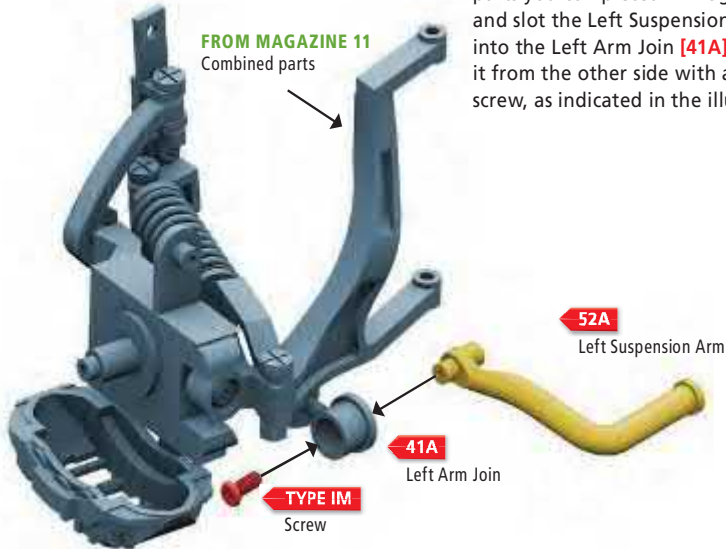

## STEP 02

### Attach the Right Suspension Arm

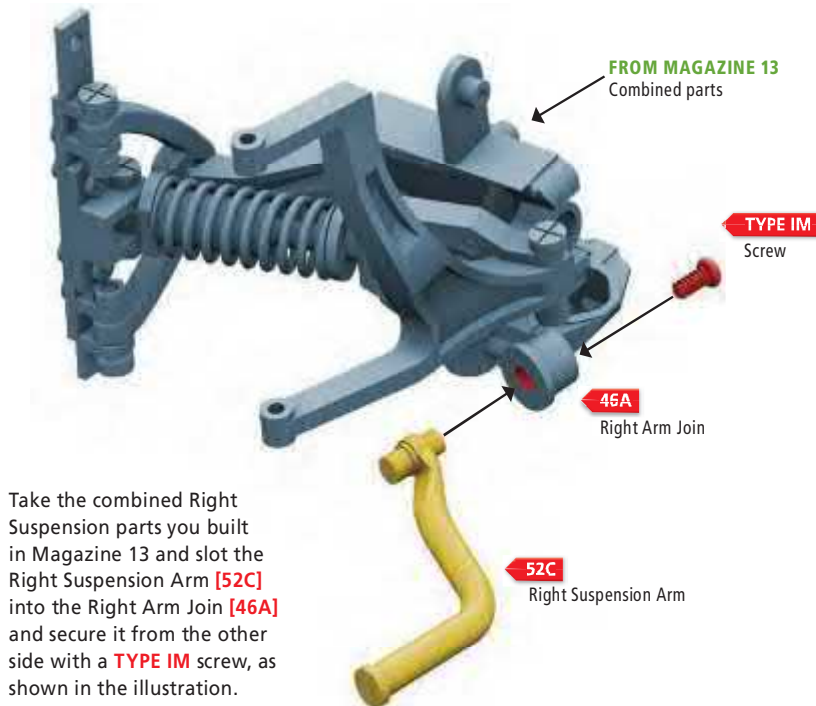

## Complete!

### The Front Suspension Arms

This is how the Right and Left Front Suspension components should look now you have attached the Front Suspension Arms.

Right

Left

**TIP!**

Don't worry if the Suspension Arms seem a bit loose. They should be able to rotate.

**TIP!**

Keep the Right and Left Arm Housings safe, as these will be attached later.

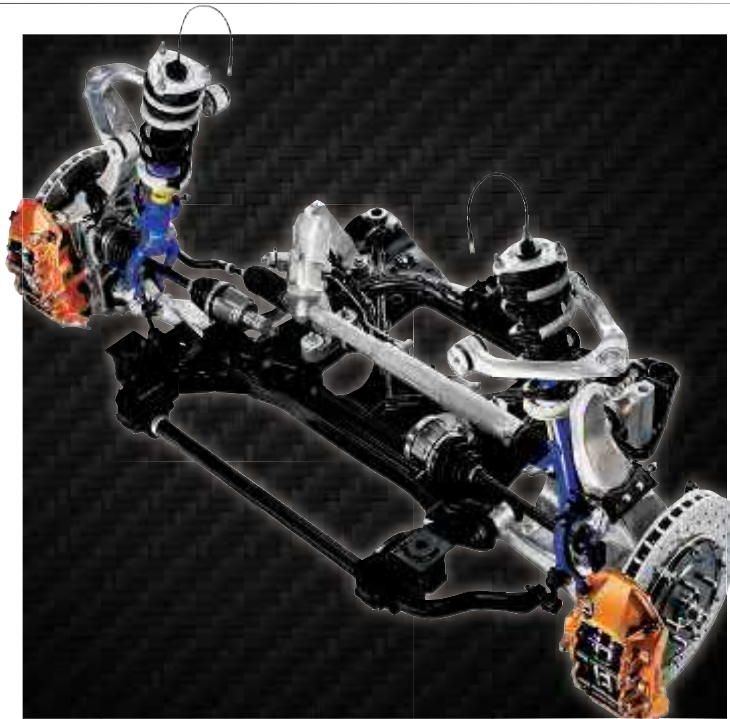

## The Front Suspension System

In the next few pages, you will build the Front Chassis Frame, attaching all the parts you have been assembling or collecting since Magazine 11. Once you have completed this, you will have finished assembling the entire Front Suspension system and it will look like the real R35 GT-R's Front Suspension, which you can see in the photo on the left.

The state-of-the-art suspension system plays a large part in making the R35 GT-R a supercar for "anyone, anytime, anywhere", because a set-up switch inside the cabin allows the driver to access three different suspension modes, depending on road conditions. These modes are: Comfort (for city driving, to absorb road bumps), Normal (the normal setting) and R (for high-performance).

In Normal or Comfort modes, the Bilstein shock absorbers are electronically controlled to produce the best handling/ride balance (depending on which setting is chosen). In R mode, the Bilstein shock absorbers firm up to provide flat, hard-cornering and maximum steering feedback.

# THE FRONT SUSPENSION SYSTEM

Next, you will attach all the parts of the Front Suspension system that you have been building or collecting to the Front Chassis Frame of your model.

## PARTS LOCATION



## PARTS LIST

### PART IDENTIFICATION LIST

PART No.	NAME	QUANTITY	MATERIAL
53A	Front Chassis Frame	1	Zinc
Screws	Type HM 0.09 x 0.16" [2.3 x 4mm]	10 [+7 spare]	Metal
Screws	Type FM 0.08 x 0.5" [2 x 13mm]	4 [+4 spare]	Metal + Nuts
Screws	Type HP 0.09 x 0.16" [2.3 x 4mm]	1 [+1 spare]	Metal
Screws	Type DM 0.08 x 0.12" [2 x 3mm]	2 [+2 spare]	Metal

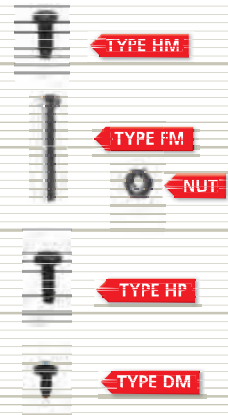

## STEP 01 Attach the Hinges to the Front Chassis Frame

Place Hinge A [41C] and Hinge B [41D], which you received with Magazine 11, and Hinge A [46C] and Hinge B [46D], which came with Magazine 12, on the Front Chassis Frame [53A], as indicated in the illustration, before securing them in place with four **TYPE HM** screws.

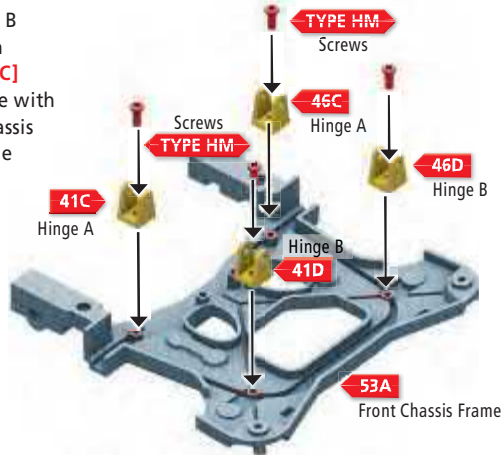

**COLOR KEY**  
■ PART BEING FITTED  
■ PART BEING FITTED TO  
■ FIXINGS



## STEP 02 Attach the Front Left Suspension Parts

Take the combined Front Left Suspension parts you completed on page 21 and insert the Left Lower Swing Arm [41B] into Hinge A [41C] and Hinge B [41D], as indicated in the illustration. Push two **TYPE FM** screws through the holes, as shown, and use the nuts to secure the parts together.

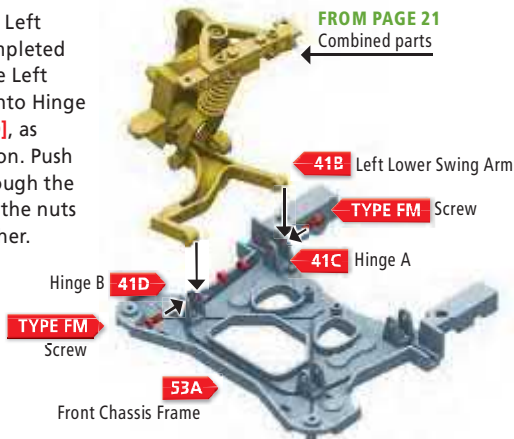

## STEP 03 Attach the Front Right Suspension Parts

Take the combined Front Right Suspension parts you completed on page 21 and insert the Right Lower Swing Arm [46B] into Hinge A [46C] and Hinge B [46D], as indicated in the illustration. Push two **TYPE FM** screws through the holes, as shown, and use the nuts to secure the parts together.

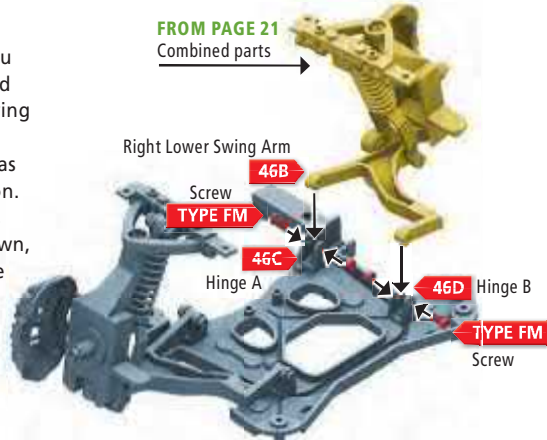

## STEP 04

### Attach the Middle & Right Front Half Shafts

Take the combined parts you assembled in Magazine 12 and slide the Right Front Half Shaft [45B] through the fork of the Stroke and then place the Middle Front Half Shaft [45C] onto the Front Chassis Frame [53A]. Now, use two TYPE HM screws from above to secure the parts in place.

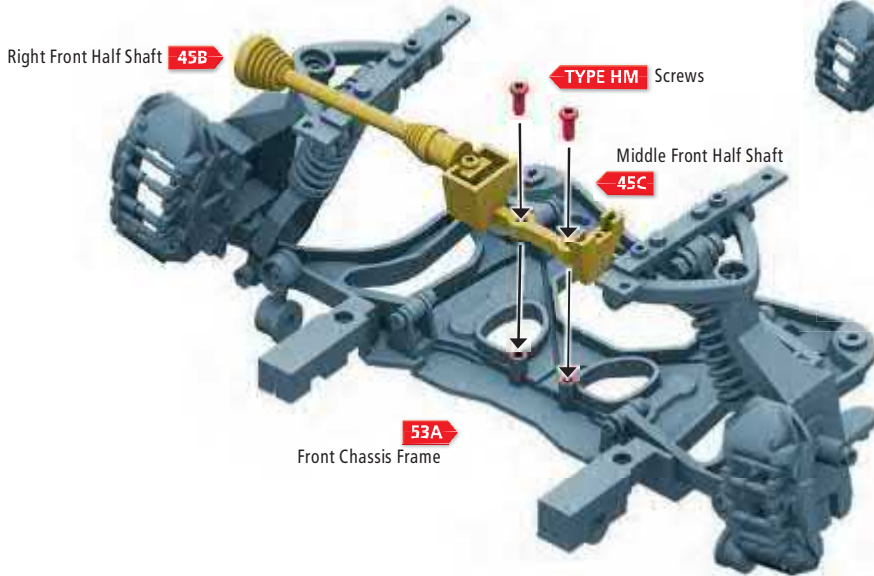

## STEP 05

### Attach the Left Front Half Shaft

Take the Left Front Half Shaft [45A] that you received with Magazine 12 and slide one end through the fork in the Stroke before attaching the other end to the Middle Front Half Shaft [45C] with a TYPE HP screw.

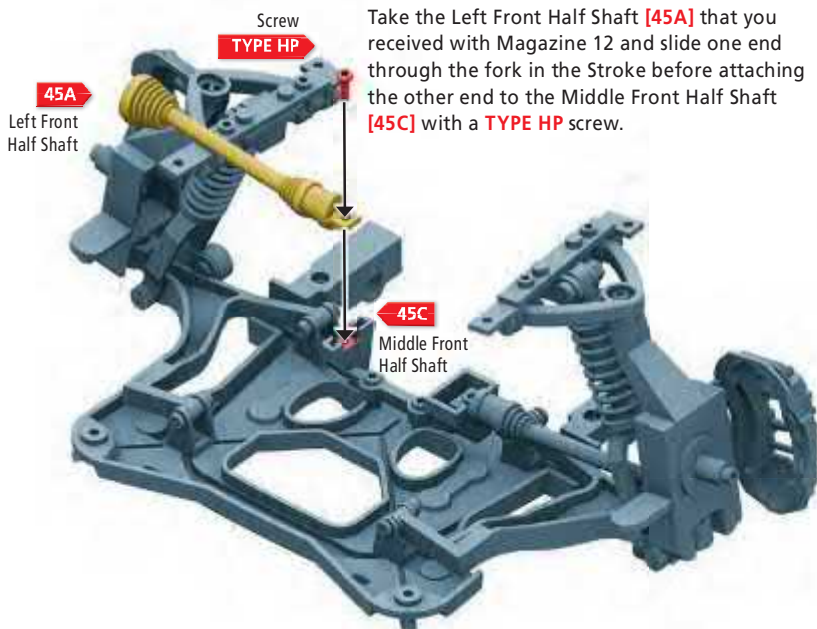



## STEP 06 Attach the Steering Shaft

Take the Steering Shaft [50A] that you received with Magazine 13 and place it so that the holes at either end go over the struts on the Knuckle Bases, as shown in the FIG.1 illustration.

FIG. 1

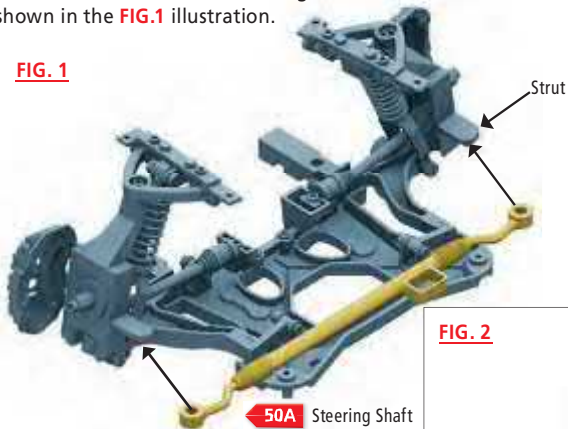

Holding the Steering Shaft [50A] firmly in place, turn the Front Chassis Frame [53A] over and use a TYPE DM screw in each of the holes indicated in FIG.2 to secure the Steering Shaft in place.

FIG. 2

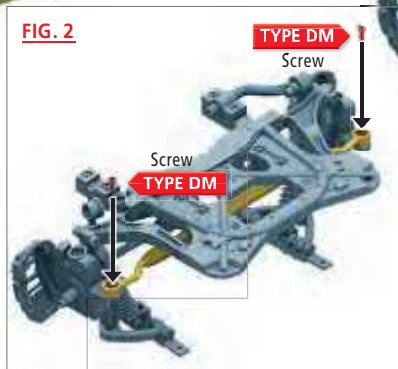

## STEP 07 Attach the Left Arm Housing

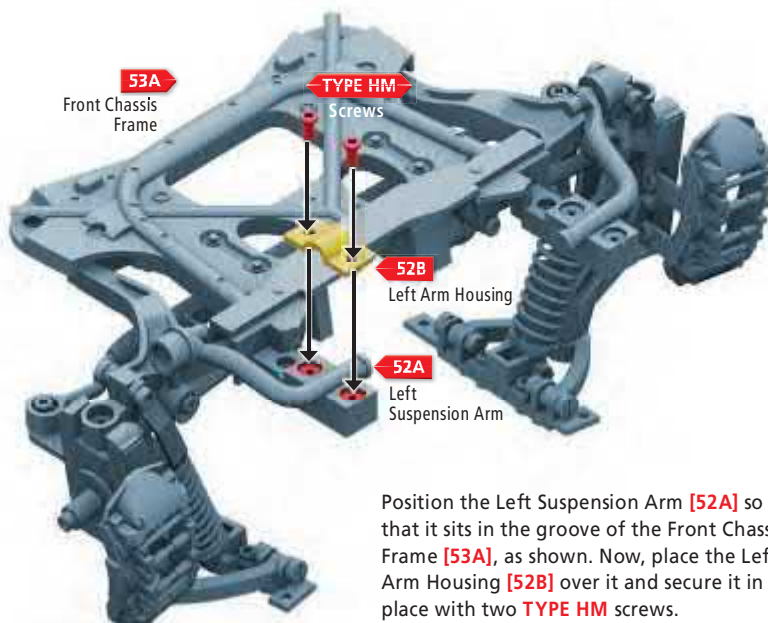

Position the Left Suspension Arm [52A] so that it sits in the groove of the Front Chassis Frame [53A], as shown. Now, place the Left Arm Frame [52B] over it and secure it in place with two TYPE HM screws.



## STEP 08 Attach the Right Arm Housing

Position the Right Suspension Arm [52C] so that it sits in the groove of the Front Chassis Frame [53A], as shown. Now, place the Right Arm Housing [52D] over it and secure it in place with two **TYPE HM** screws.

Front Chassis Frame [53A]

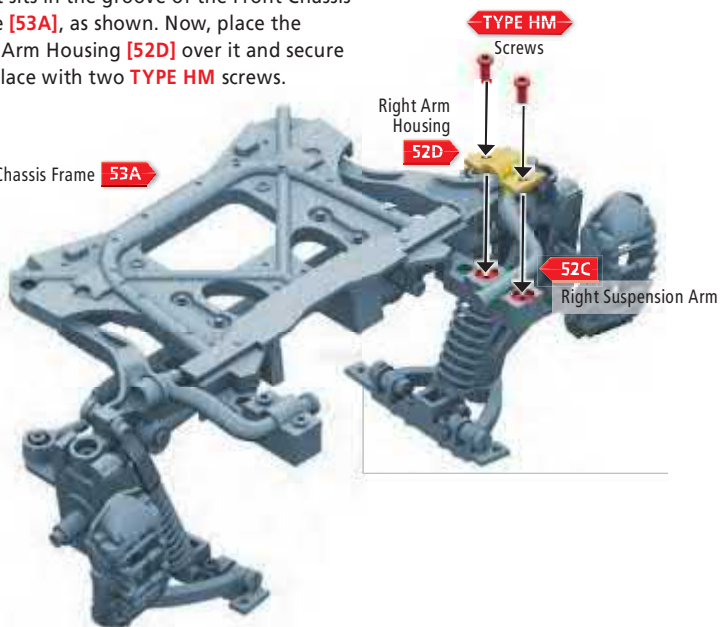

## Complete! The Front Suspension System

This is how the Front Suspension System should look once you have fully assembled it.



## THE DASHBOARD

Now you will begin to assemble the parts that make up the Dashboard of your NISSAN GT-R (R35) model.

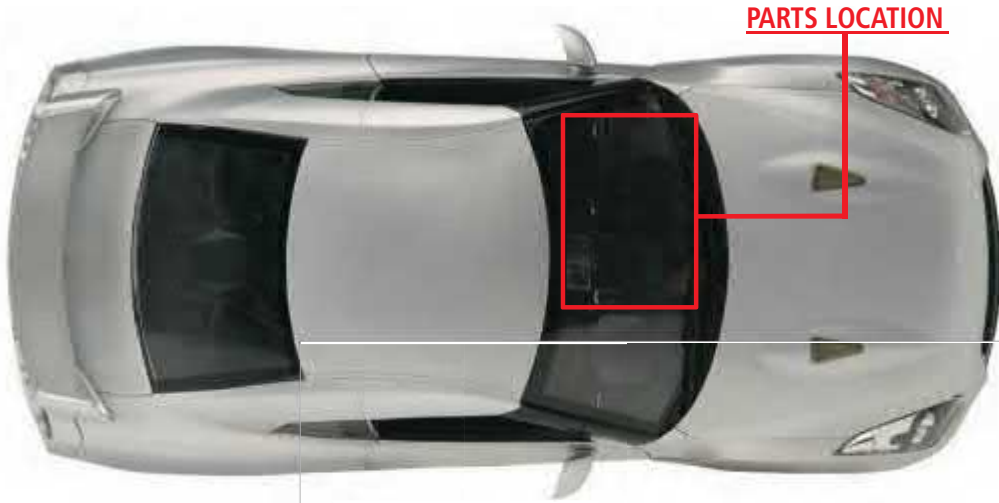

**PARTS LOCATION**

### PARTS LIST

#### PART IDENTIFICATION LIST

PART No.	NAME	QUANTITY	MATERIAL
54A	Dashboard	1	ABS
54B	Instrument Panel	1	GP
54C	Instrument Cluster	1	GP
54D	Instrument Indicator	1	
54E	Instrument Holder	1	ABS
Screws	Type GP 0.08 x 0.16" [2 x 4mm]	4 [+2 spare]	Metal



54A



TYPE GP



54B



54C

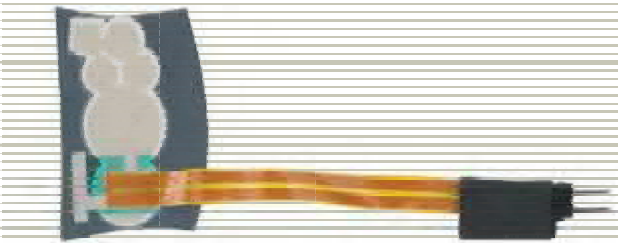

54D



54E

## STEP 01

### Add the Instrument Panel

Push the Instrument Panel [54B] into the back of the Dashboard [54A], so that the pegs on the bottom corners of the Instrument Panel slide into the holes indicated in the illustration.

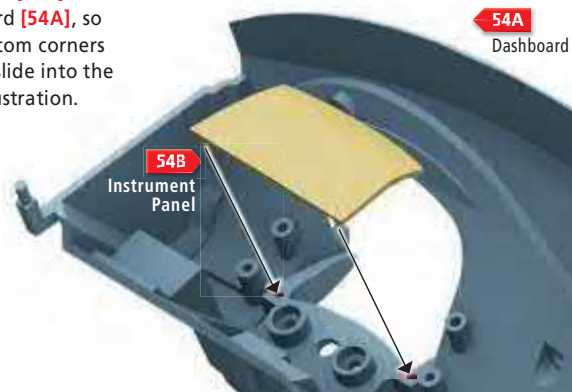

## STEP 02

### Attach the Instrument Cluster

Push the Instrument Cluster [54C] over the top of the Instrument Panel [54B] and secure it to the Dashboard [54A] with two TYPE GP screws in the holes indicated in the illustration.

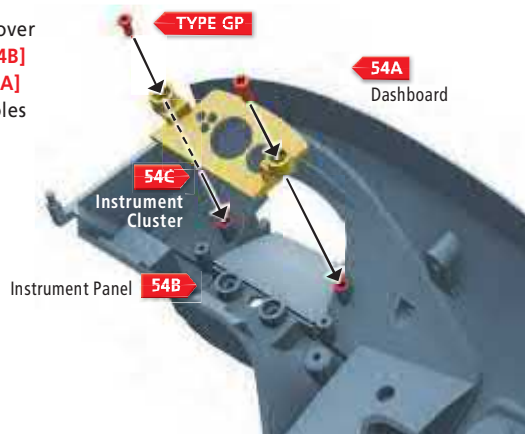

## STEP 03

### Attach the Instrument Indicator

Place the Instrument Indicator [54D] over the top of the Instrument Cluster [54C] so that the side with the wire attached to it is facing towards you and is on the right hand side, as indicated in the illustration.

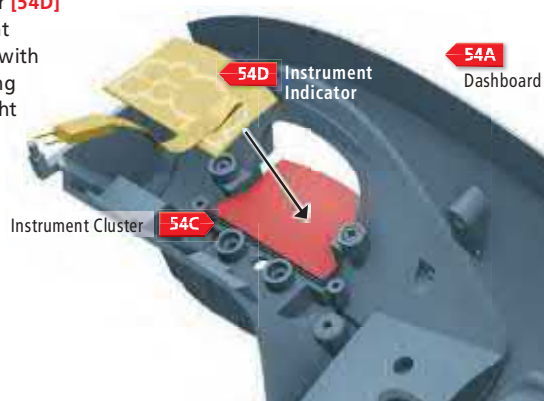

## STEP 04 Add the Instrument Holder

Place the Instrument Holder [54E] over the top of the Instrument Indicator [54D], so that it holds it in place, and then secure the Instrument Holder in place with two TYPE GP screws, as shown in the illustration.

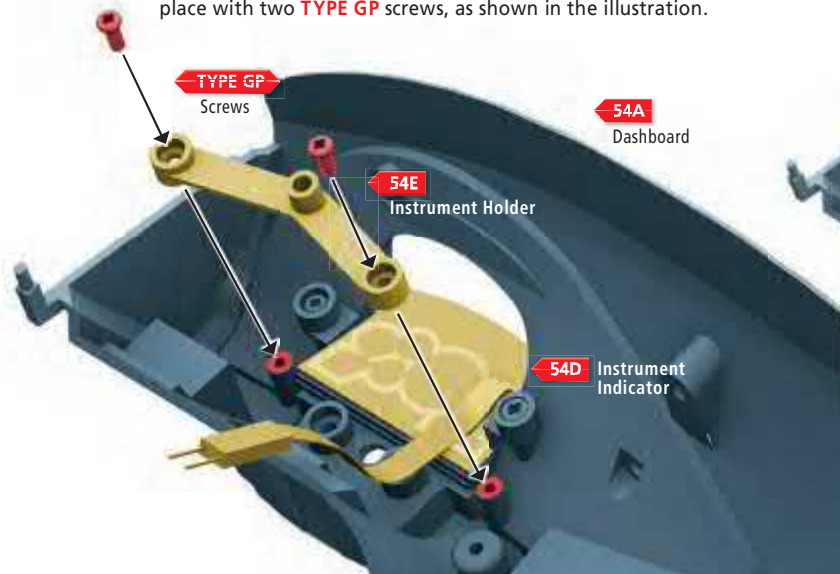

## Complete!

### The Dashboard

This is how the rear view of the Dashboard should look once you have assembled the parts that came with this magazine.





# HOW TO BUILD

## THE DASHBOARD

In this section, you will finish assembling the Dashboard of your NISSAN GT-R (R35) model.

### PARTS LOCATION

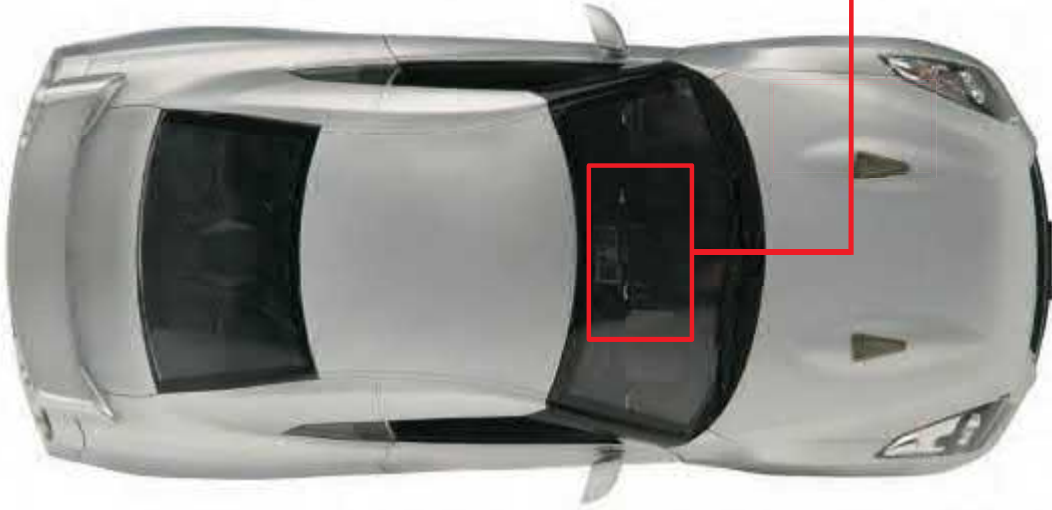

### PARTS LIST

#### PART IDENTIFICATION LIST

PART No.	NAME	QUANTITY	MATERIAL
55A	Multifunction Display Panel	1	ABS
55B	Dashboard Controls	1	ABS
55C	Control Buttons	1	ABS
55D	Instrument Cover	1	ABS
55E	Power Outlet Button	1	ABS
Screws	Type GP 0.08 x 0.16" [2 x 4mm]	6 [+ 3 spares]	Metal
Screws	Type HP 0.09 x 0.16" [2.3 x 4mm]	2 [+1 spare]	Metal



55A

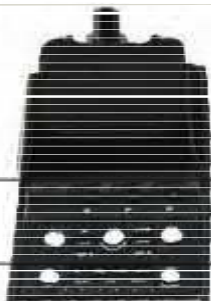

55B



55C



55D



55E



TYPE GP



TYPE HP

## STEP 01

### Attach the Instrument Cover

Place the Instrument Cover [55D] over the top of the Instrument Cluster, as indicated in the illustration, and then secure it to the Dashboard [54A] with two **TYPE GP** screws.



#### COLOR KEY

- PART BEING FITTED
- PART BEING FITTED TO
- FIXINGS

#### STEP 01 COMPLETE



## STEP 02

### Assemble the Dashboard Controls & Buttons

Push the Control Buttons [55C] into the back of the Dashboard Controls [55B], so that the buttons fit through the holes, and then secure the Control Buttons in place with two **TYPE GP** screws, as shown in the illustration.

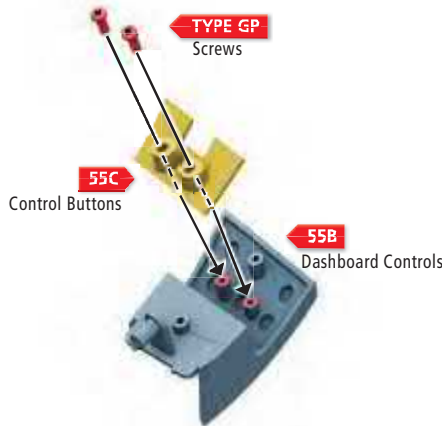

#### STEP 02 COMPLETE



## STEP 03

### Attach the combined Dashboard Controls & Buttons

FIG. 1



Push the combined Dashboard Controls and Buttons [55B/C] into the front of the Dashboard [54A] and then use two **TYPE GP** screws in the back of the Dashboard to secure the parts in place.

FIG. 2

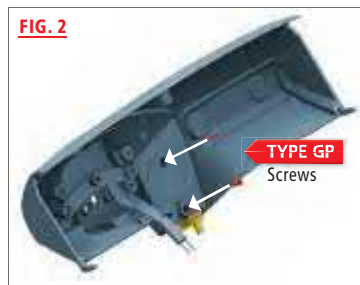

#### STEP 03 COMPLETE





## STEP 04 Attach the Multifunction Display Panel

Push the Multifunction Display Panel [55A] into the holes on top of the Dashboard [54A], as indicated in FIG.1. Secure it in place from the back of the Dashboard with two TYPE HP screws, as shown in FIG.2.

FIG. 1



FIG. 2

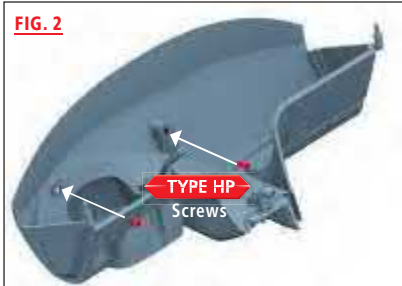

STEP 04 COMPLETE



## STEP 05 Attach the Power Outlet Button

Push the Power Outlet Button [55E] firmly into the hole in the Dashboard [54A], as indicated in the illustration. This part just pushes in and will hold securely without the need for screws.



STEP 05 COMPLETE



## Complete!

### The Dashboard

This is how the Dashboard should look once you have completed this stage of the build.



# THE STEERING SYSTEM

Now you will begin to assemble the parts that make up the Steering System of your NISSAN GT-R (R35) model.

## PARTS LOCATION

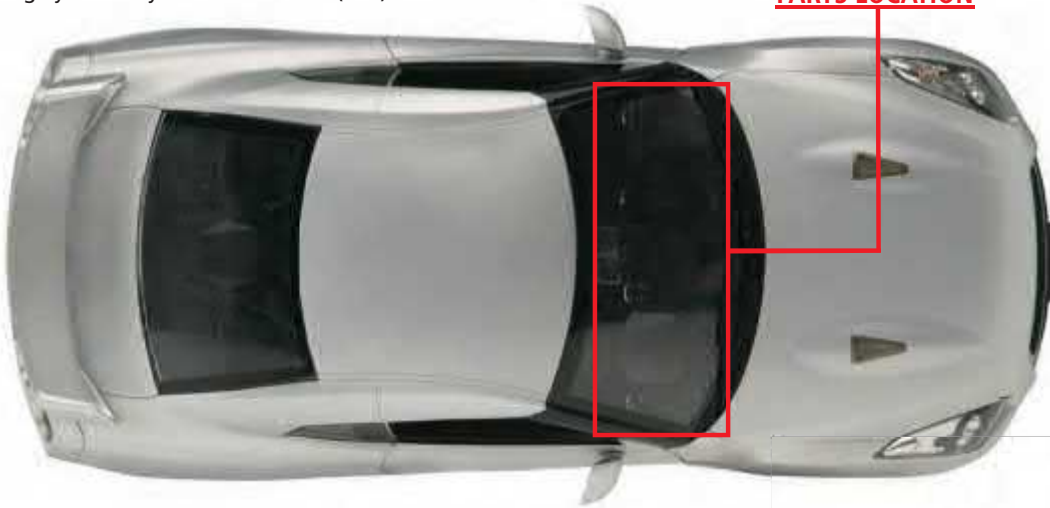

## PARTS LIST

## PART IDENTIFICATION LIST

PART No.	NAME	QUANTITY	MATERIAL
56A	Steering Wheel	1	ABS
56B	Paddle Shift	1	ABS
56C	Steering Column Trim	1	ABS
56D	Steering Shaft	1	Zinc
56E	Dashboard Panel	1	Photo Etch
Screws	Type GP 0.08 x 0.16" [2 x 4mm]	4 [+2 spares]	Metal
Screws	Type HP 0.09 x 0.16" [2.3 x 4mm]	2 [+1 spare]	Metal
Screws	Type DM 0.08 x 0.12" [2 x 3mm]	1 [+1 spare]	Metal



56A



56B

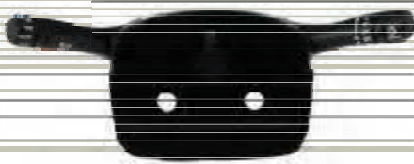

56C



TYPE GP



TYPE HP



TYPE DM

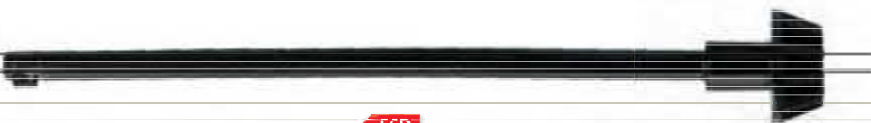

56D



56E

## STEP 01 Attach the Paddle Shift

Push the two struts on the back of the Paddle Shift [56B] into the two holes in the Steering Column Trim [56C], as indicated in the illustration. Ensure that you hold the Steering Column Trim the correct way up, with the indicator stalks at the top.

### COLOR KEY

- PART BEING FITTED
- PART BEING FITTED TO
- FIXINGS



## STEP 02 Secure the Paddle Shift to the Steering Column

Holding the Paddle Shift [56B] firmly in place, turn the Steering Column Trim [56C] over, so that you are looking at the back of it, and secure the parts together with two TYPE GP screws in the holes indicated in the illustration.

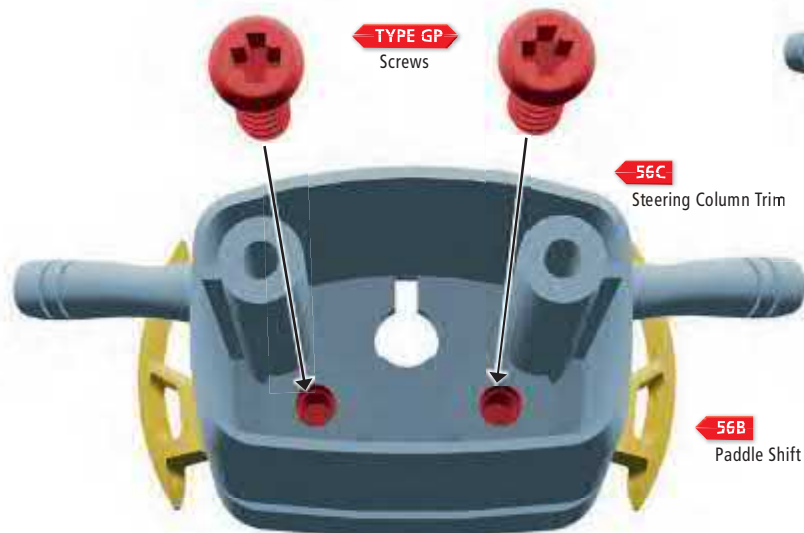

### STEP 03

#### Attach the combined Paddle Shift and Steering Column Trim

FROM STEP 02  
Combined parts



STEP 03 COMPLETE



Take the combined Paddle Shift and Steering Column Trim [56B/C] and push it into the space on the Dashboard [54A] indicated in the illustration. Again, make sure that the Steering Column Trim is the correct way up, with the indicator stalks at the top.

### STEP 04

#### Secure the combined Paddle Shift and Steering Column Trim

Dashboard 54A



STEP 04 COMPLETE



Holding the combined Paddle Shift and Steering Column Trim [56B/C] firmly in place, turn the Dashboard [54A] over, so that you are looking at the back of it, and secure the parts together with two TYPE GP screws in the holes indicated in the illustration.

## STEP 05 Attach the Dashboard to the Interior Base

**23A**  
Interior Base

Attach the Dashboard [54A] to the Interior Base [23A] by sliding the struts highlighted by the red circles on the illustration into the holes on each side of the Interior Base.

**54A**  
Dashboard

STEP 05 COMPLETE



## STEP 06 Secure the Dashboard to the Interior Base

Secure the Dashboard [54A] to the Interior Base [23A] using one TYPE HP screw in the top of the Dashboard, as shown in FIG.1,

and one TYPE HP screw in the underside of the Interior Base, as shown in FIG.2.

FIG. 1

FIG. 2

**23A**  
Interior Base

**TYPE HP**  
Screw

**TYPE HP**  
Screw

**54A**  
Dashboard

STEP 06 COMPLETE

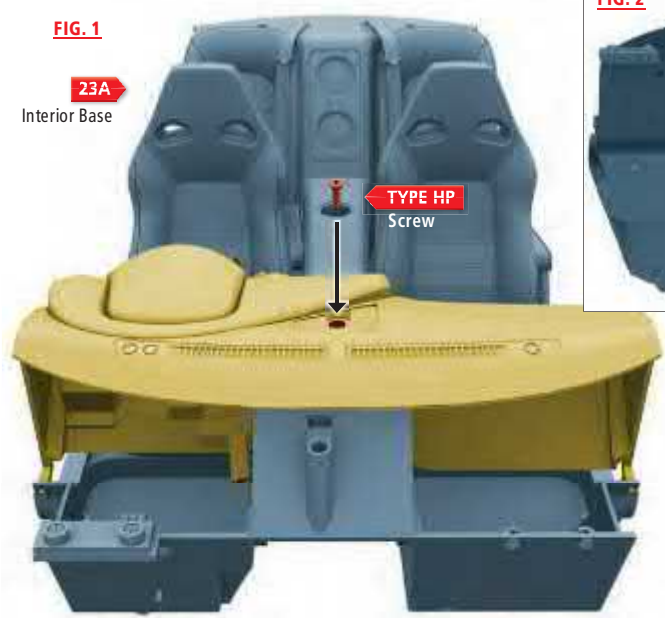

## STEP 07 Attach the Steering Shaft

Line up the notch on the end of the Steering Shaft [56D] so that it can be pushed through the hole in the Interior Base [23A]. Next, turn the Steering Shaft so that the notch can pass through the hole in the back of the Dashboard [54A] and turn it again until it can be pushed through the hole in the back of the Steering Column Trim [56C].

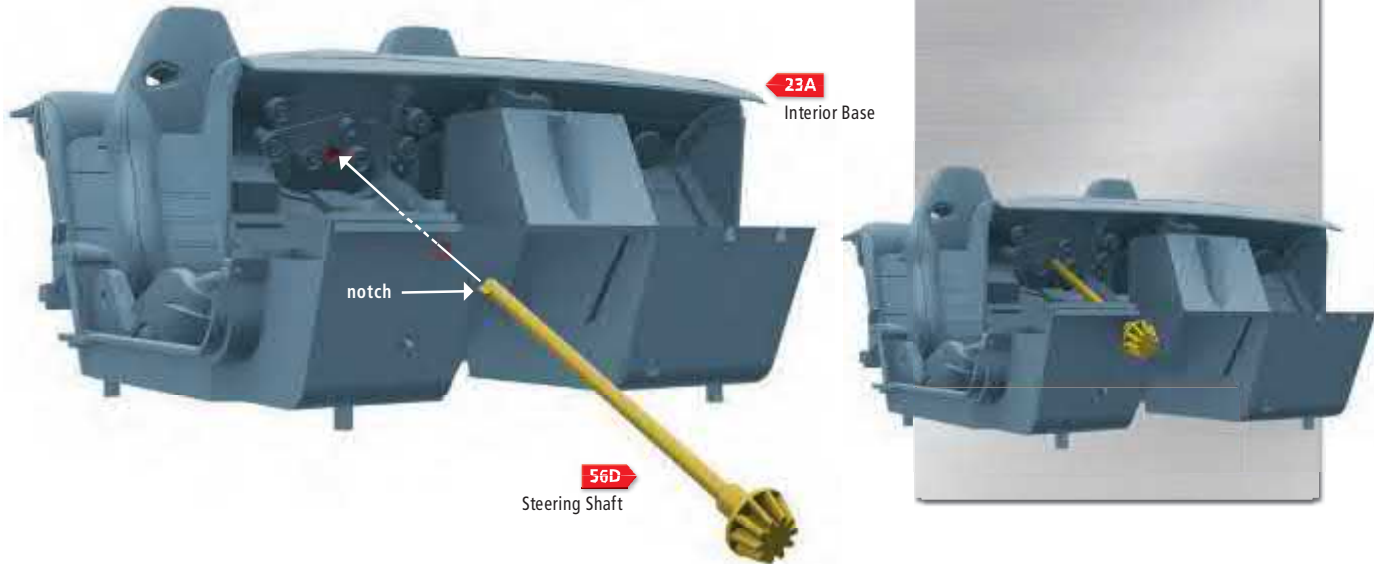

## STEP 08 Attach the Steering Wheel

Line up the Steering Wheel [56A] with the protruding notch on the end of the Steering Shaft [56D], as shown in FIG.1.

FIG. 1



FIG. 2



Now, use one TYPE DM screw in the center of the Steering Wheel [56A], as shown in FIG.2, to secure it to the Steering Column Trim [56C].



## STEP 09 Attach the Dashboard Panel

Unpeel the label on the back of the Dashboard Panel [56E] and then place it, sticky side down, on the area indicated in the illustration, so that it covers the screw used to hold the Dashboard [54A] in place.

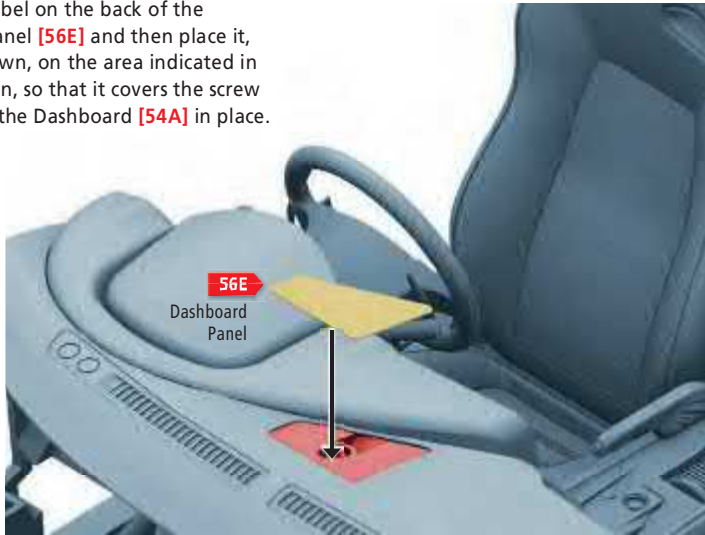

## Complete!

### The Steering System

This is how the interior should look once you have assembled these parts.



# THE STEERING RACK

Now it is time to assemble the Steering Wheel parts and attach them and the Rear Speakers to your NISSAN GT-R (R35) model.

## PARTS LOCATION

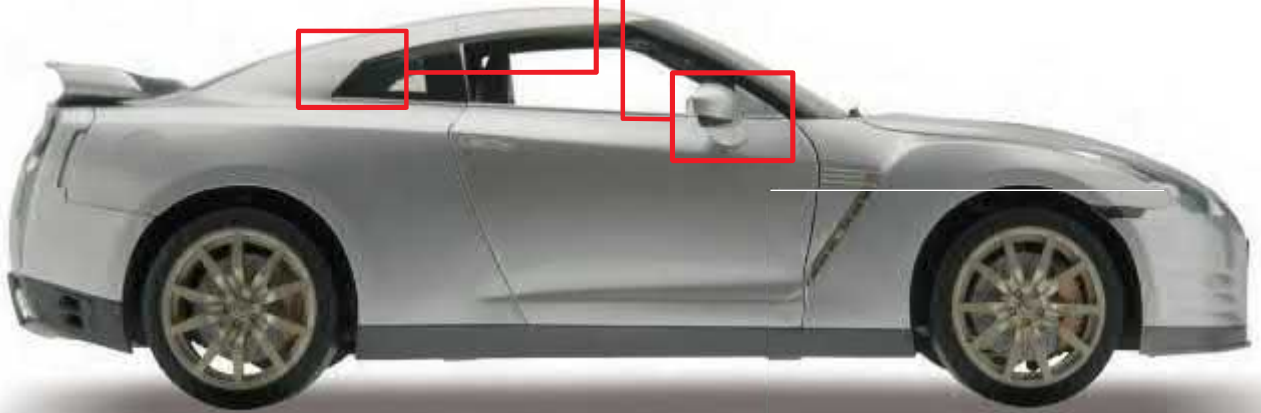

## PARTS LIST

### PART IDENTIFICATION LIST

PART No.	NAME	QUANTITY	MATERIAL
57A	Steering Wheel Center Cap	1	ABS
57B	Steering Console	1	ABS
57C	Left Rear Speaker	1	ABS
57D	Right Rear Speaker	1	ABS
Screws	Type HP 0.09 x 0.16" [2.3 x 4mm]	2 [+1 spare]	Metal

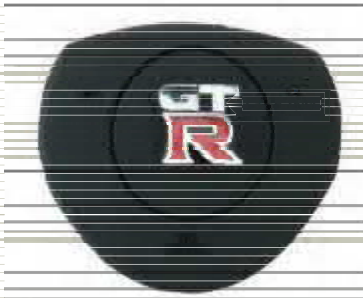

57A



TYPE HP



57B



57C



57D



## STEP 01 Attach the Steering Console

Push the Steering Console [57B] onto the center of the Steering Wheel [56A], so that the round holes in both parts line up, as indicated in the illustration. The Steering Console just pushes into place and will hold securely without the need for screws.

### COLOR KEY

- PART BEING FITTED
- PART BEING FITTED TO
- FIXINGS



## STEP 02 Attach the Steering Wheel Center Cap

Push the strut on the back of the Steering Wheel Center Cap [57A] into the hole in the centre of the Steering Console [57B], as indicated in the illustration. The Steering Wheel Center Cap just pushes into place and will hold securely without the need for screws.

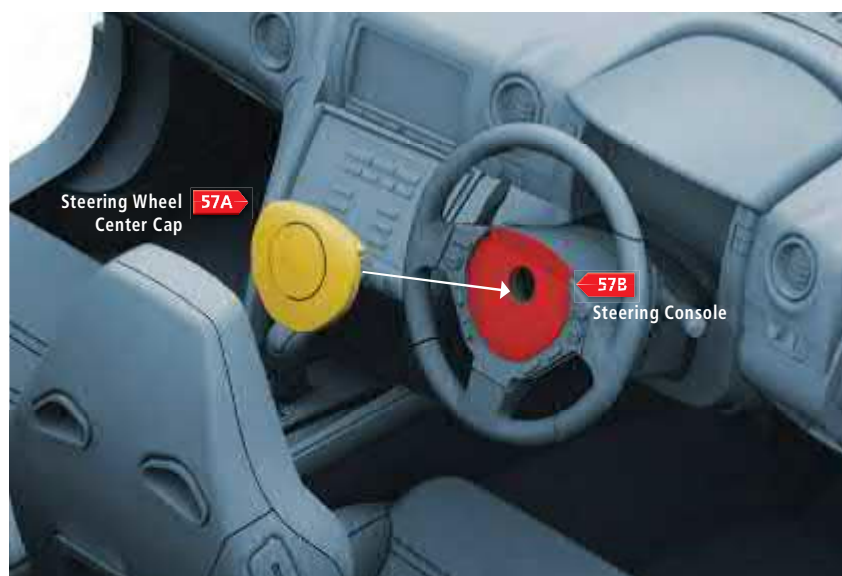

### STEP 03 Attach the Left Rear Speaker

Push the struts on the back of the Left Rear Speaker [57C] into the two holes on the Interior Base [23A], as indicated in FIG.1. Now, turn the Interior Base over and secure the Left Rear Speaker with a TYPE HP screw, as shown in FIG.2.

FIG. 1



FIG. 2

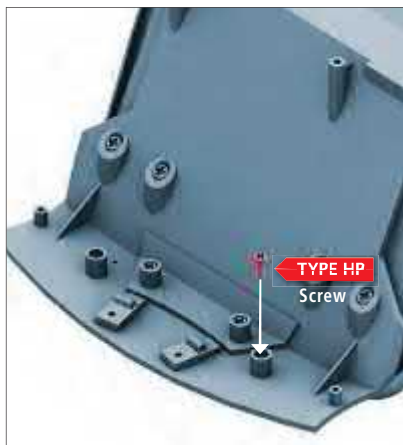

### STEP 04 Attach the Right Rear Speaker

Push the struts on the back of the Right Rear Speaker [57D] into the two holes on the Interior Base [23A], as indicated in FIG.1. Now, turn the Interior Base over and secure the Right Rear Speaker with a TYPE HP screw, as shown in FIG.2.

FIG. 1

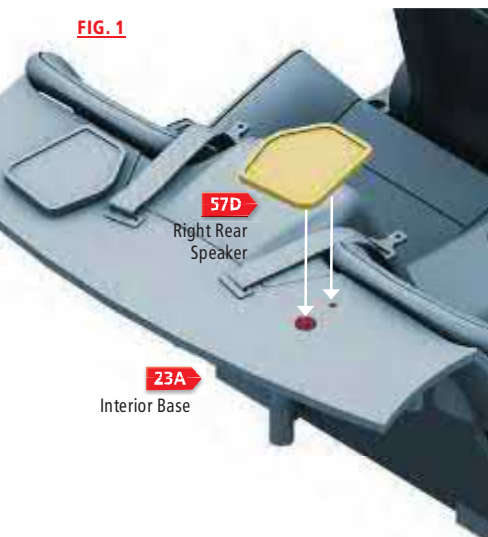
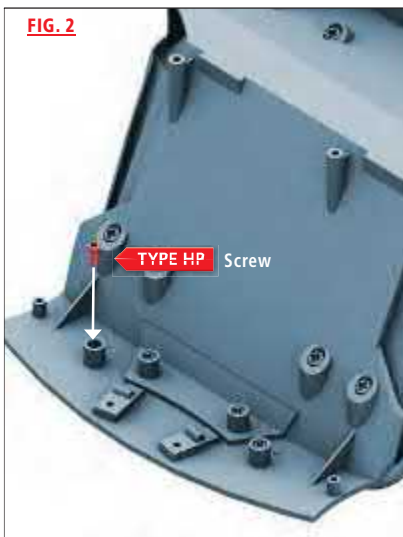

FIG. 2



## *Complete!*

### The Steering Wheel parts

This is how the Steering Wheel parts should look after assembly.



## *Complete!*

### The Rear Speakers

This is how the back of the car's interior should look once you have added the Rear Speakers.



# REAR LEFT SIDE PANEL & FRONT SEAT BELT

Next, you will add the Rear Left Side Panel and Front Left Seat Belt to the interior of your NISSAN GT-R (R35) model.



**PARTS LOCATION**

## PARTS LIST

### PART IDENTIFICATION LIST

PART No.	NAME	QUANTITY	MATERIAL
58A	Rear Left Side Panel	1	ABS
58B	Seat Belt Clip	1	ABS
58C	Left Seat Belt Holder	1	ABS
58D	Left Seat Belt Pin 1	1	ABS
58E	Left Seat Belt Pin 2	1	ABS
58F	Front Seat Belt	1	Nylon
Screws	Type GP 0.08 x 0.16" [2 x 4mm]	6 [+ 4 spare]	



**TIP!**  
The Left Seat Belt Pins have either 'L1' or 'L2' written on them, so that you can tell them apart.

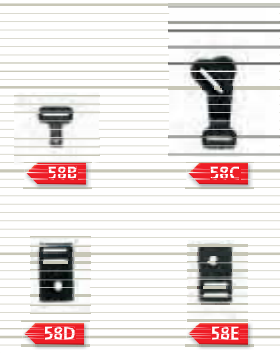

## STEP 01 Thread the Seat Belt through Left Seat Belt Pin 2

Thread one end of the Front Seat Belt [58F] in and out of the holes of Left Seat Belt Pin 2 [58E], as shown in the illustration. Make sure that this Seat Belt Pin has 'L2' printed on it.

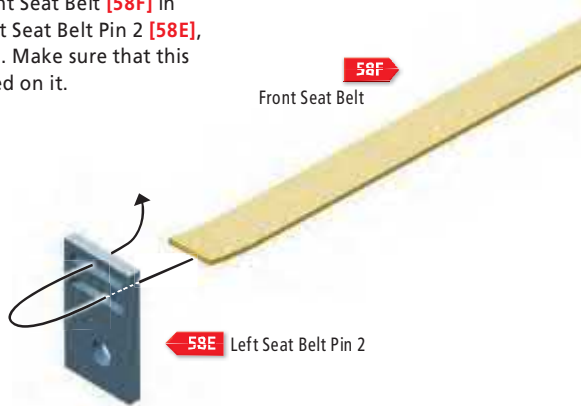

**COLOR KEY**  
■ PART BEING FITTED  
■ PART BEING FITTED TO  
■ FIXINGS



## STEP 02 Attach Left Seat Belt Pin 2



Match up the peg and hole on Left Seat Belt Pin 2 [58E] with the area on the Rear Left Side Panel [58A] indicated in the illustration. You will notice it is marked 'L2', indicating that Left Seat Belt Pin 2 goes here. Secure it in place with a TYPE GP screw from above.



## STEP 03 Thread the Front Seat Belt through the Rear Left Side Panel

Thread the Front Seat Belt [58F] through the hole on the inside of the Rear Left Side Panel [58A], as shown in the illustration.

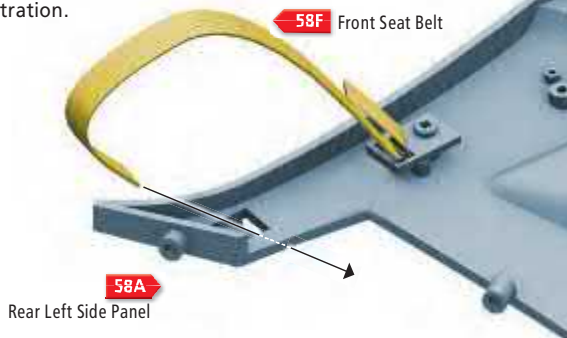

## STEP 04 Attach the Seat Belt Clip

Having pulled the Front Seat Belt [58F] through the hole at the bottom of the Rear Left Side Panel [58A], thread the Seat Belt Clip [58B] onto it, as shown in the illustration.



## STEP 05 Add the Left Seat Belt Holder

Thread the Front Seat Belt [58F] through the hole of the Left Seat Belt Holder [58C], as shown in the illustration. Take care not to twist the Front Seat Belt while doing this.



## STEP 06 Thread the Front Seat Belt through the Rear Left Side Panel

Thread the Front Seat Belt [58F] through the hole on the inside of the Rear Left Side Panel [58A], as shown in the illustration.

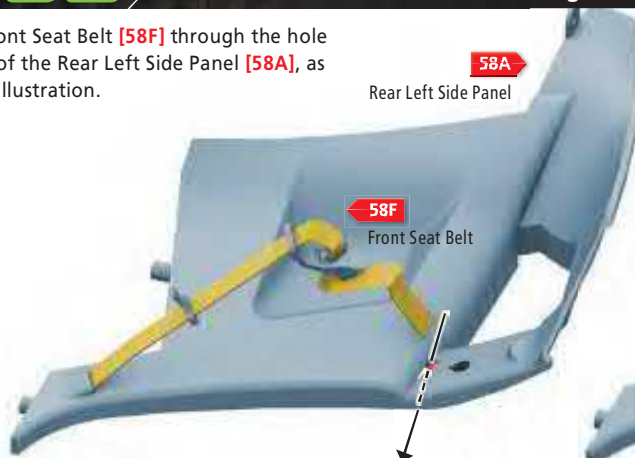

## STEP 07 Attach the Left Seat Belt Holder

Push the top of the Left Seat Belt Holder [58C] into the hole in the Rear Left Side Panel [58A], as shown in the illustration. Make sure that you keep the Front Seat Belt [58F] taut by pulling it from the other side of the Rear Left Side Panel.

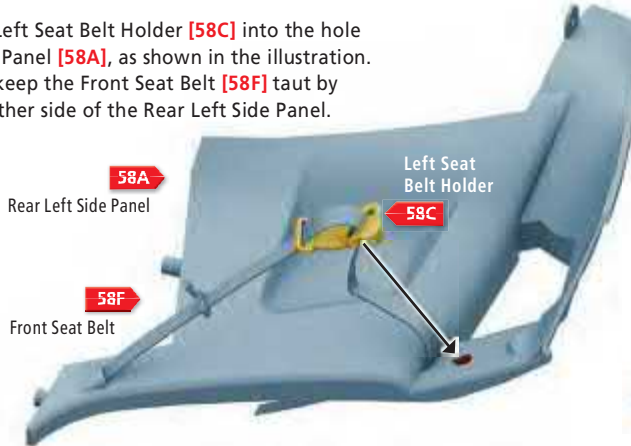

## STEP 08 Secure the Left Seat Belt Holder

Holding the Left Seat Belt Holder [58C] firmly in place, turn the Rear Left Side Panel [58A] over and use one TYPE GP screw in the hole shown in the illustration to secure the parts together.

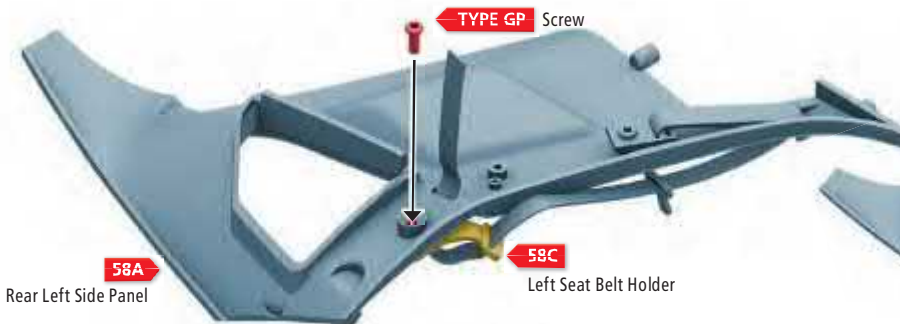

## STEP 09 Attach Left Seat Belt Pin 1

Thread the Front Seat Belt [58F] through Left Seat Belt Pin 1 [58D], as shown in FIG.1. Now, secure Left Seat Belt Pin 1 to the Rear Left Side Panel [58A] with a TYPE GP screw, as shown in FIG.2.

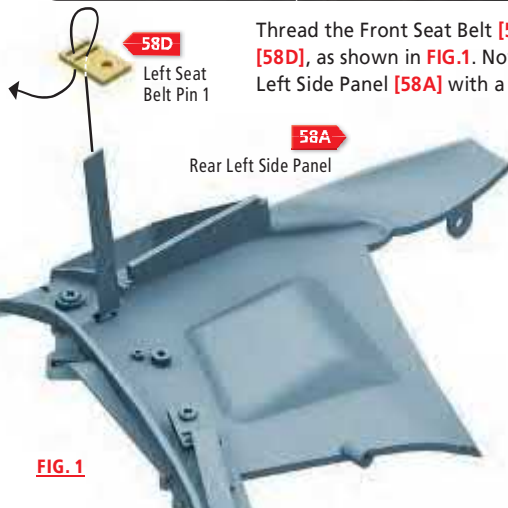

## STEP 10

### Attach the Rear Left Side Panel to the Interior Base

Push the two pegs on the bottom of the Rear Left Side Panel [58A] into the two holes indicated (right) in the Interior Base [23A], while also lining up the hole at the back of the Rear Left Side Panel with the peg that extends from below the Rear Parcel Shelf on the Interior Base, as shown in FIG.1.

FIG. 1

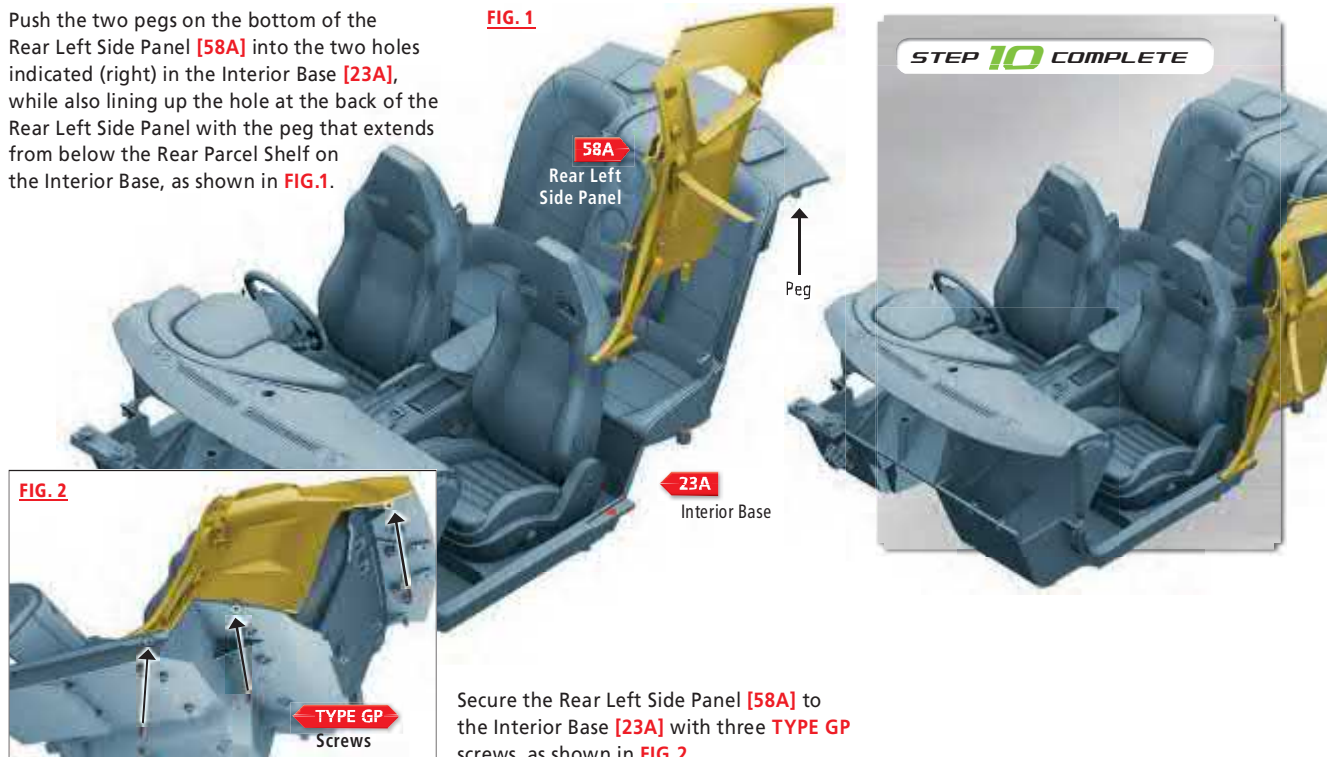

Secure the Rear Left Side Panel [58A] to the Interior Base [23A] with three TYPE GP screws, as shown in FIG.2.

## Complete!

### Rear Left Passenger Panel

This is how the interior should look once you have added these parts.



## REAR RIGHT SIDE PANEL & FRONT SEAT BELT

In this magazine you will add the Rear Right Side Panel and Front Right Seat Belt to the interior of your NISSAN GT-R (R35).

### PARTS LOCATION

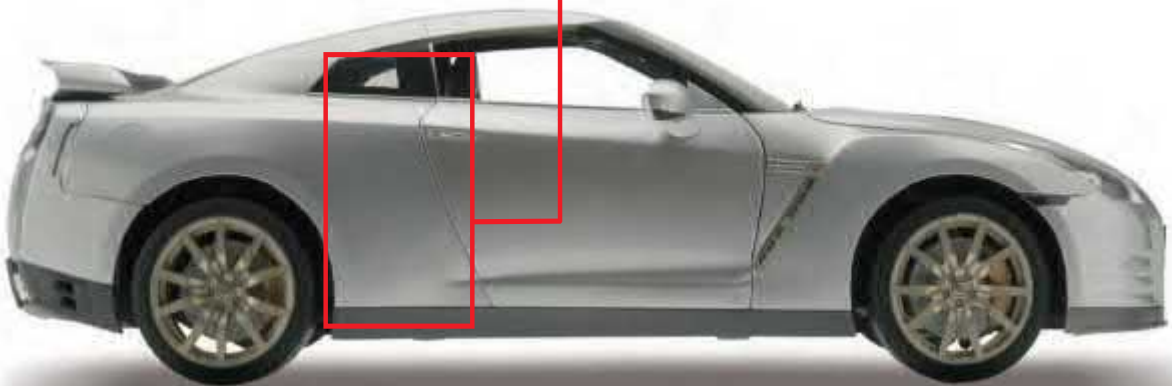

### PARTS LIST



TYPE GP

### PART IDENTIFICATION LIST

PART No.	NAME	QUANTITY	MATERIAL
59A	Rear Right Side Panel	1	ABS
59B	Seat Belt Clip	1	ABS
59C	Right Seat Belt Holder	1	ABS
59D	Right Seat Belt Pin 1	1	ABS
59E	Right Seat Belt Pin 2	1	ABS
59F	Front Right Seat Belt	1	Nylon
Screws	Type GP 0.08 x 0.16" [2 x 4mm]	6 [+4 spare]	Metal

**TIP!**  
The Right Seat Belt Pins have either 'R1' or 'R2' written on them, so that you can tell them apart.

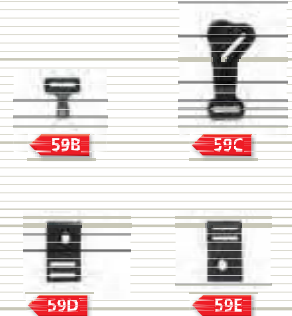

## STEP 01

### Thread the Front Right Seat Belt

Thread one end of the Front Right Seat Belt [59F] in and out of the holes of Right Seat Belt Pin 2 [59E], as indicated in the illustration. Make sure Right Seat Belt Pin 2 has 'R2' printed on it.

#### COLOR KEY

- PART BEING FITTED
- PART BEING FITTED TO
- FIXINGS

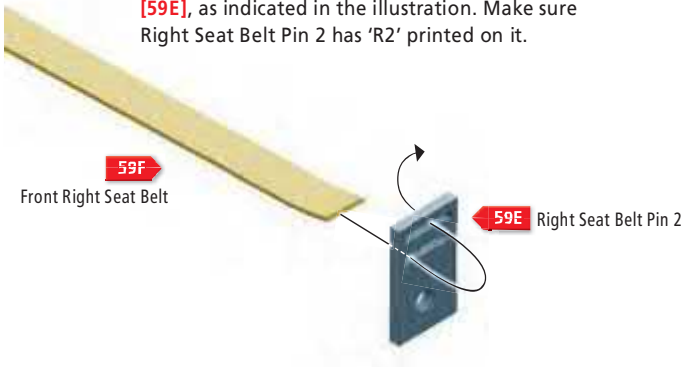

## STEP 02

### Attach Right Seat Belt Pin 2

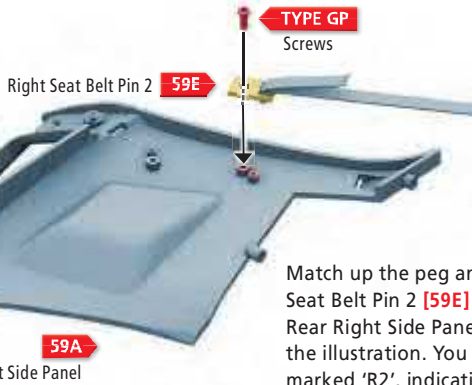

Match up the peg and the hole on Right Seat Belt Pin 2 [59E] with the area on the Rear Right Side Panel [59A] indicated in the illustration. You will notice that it is marked 'R2', indicating that Right Seat Belt Pin 2 goes here. Secure it in place with a TYPE GP screw from above.



## STEP 03

### Thread the Front Right Seat Belt



Thread the Front Right Seat Belt [59F] through the hole on the inside of the Rear Right Side Panel [59A], as indicated in the illustration.



## STEP 04 Attach the Seat Belt Clip

Having pulled the Front Right Seat Belt [59F] through the hole at the bottom of the Rear Right Side Panel [59A], thread the Seat Belt Clip [59B] onto it, as shown in the illustration.



## STEP 05 Add the Right Seat Belt Holder

Thread the Front Right Seat Belt [59F] through the hole of the Right Seat Belt Holder [59C], as indicated in the illustration. Take care not to twist the Front Right Seat Belt.

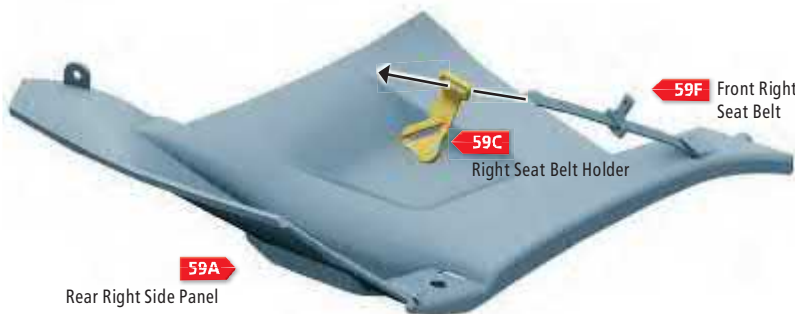

## STEP 06 Thread the Front Right Seat Belt through the Rear Right Side Panel

Thread the Front Right Seat Belt [59F] through the hole in the Rear Right Side Panel [59A], as indicated by the arrow in the illustration.

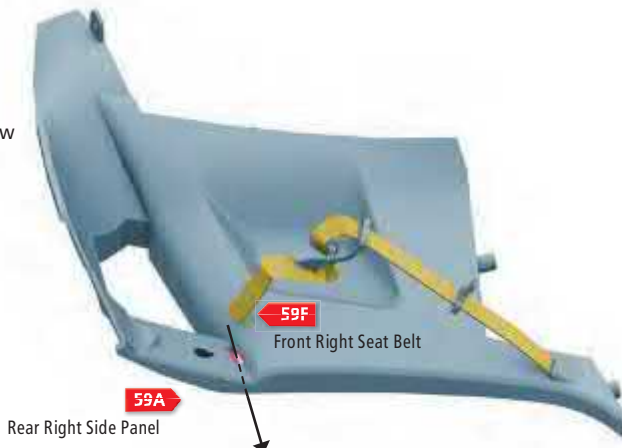

## STEP 07

### Attach the Right Seat Belt Holder

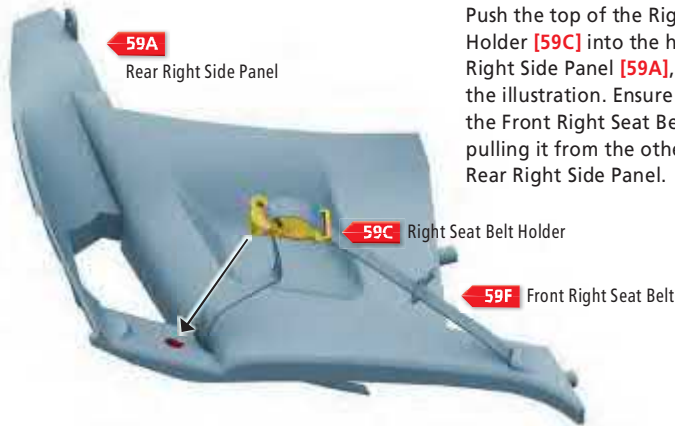

STEP 07 COMPLETE



## STEP 08

### Secure the Right Seat Belt Holder

Holding the Right Seat Belt Holder [59C] firmly in place, turn the Rear Right Side Panel [59A] over and use one TYPE GP screw to secure the parts together.

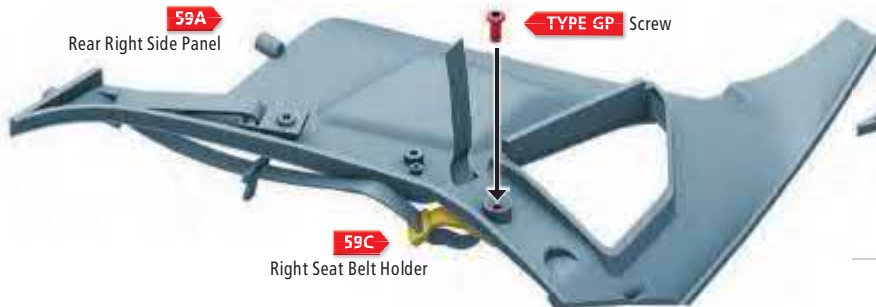

STEP 08 COMPLETE



## STEP 09

### Attach Right Seat Belt Pin 1

Thread the Front Right Seat Belt [59F] through Right Seat Belt Pin 1 [59D], as shown in FIG.1. Next, secure Right Seat Belt Pin 1 to the Rear Right Side Panel [59A] with a TYPE GP screw, as shown in FIG.2.

FIG. 2



FIG. 1

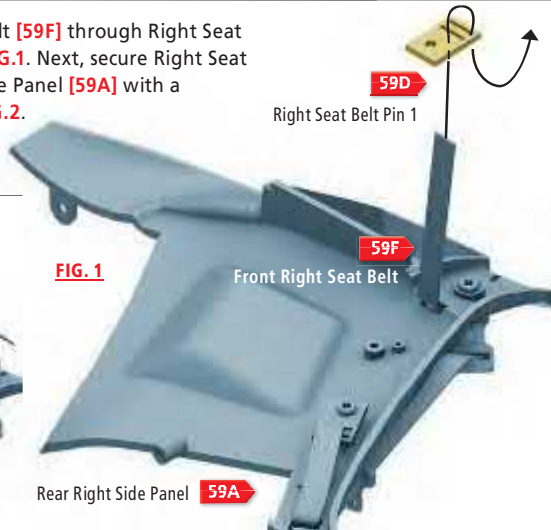

STEP 09 COMPLETE



## STEP 10

### Attach the Rear Right Side Panel

Push the two pegs on the bottom of the Rear Right Side Panel [59A] into the two holes indicated (below) in the Interior Base [23A], while also lining up the hole at the back of the Rear Right Side Panel with the peg that extends below the Rear Parcel Shelf on the Interior Base, as shown in FIG.1.

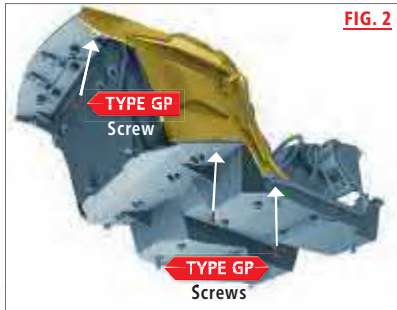

Secure the Rear Right Side Panel [59A] to the Interior Base [23A] with three TYPE GP screws, as indicated by the white arrows in FIG.2 (above).

## Complete!

### Rear Right Side Panel

This is how the interior should look once you have added these new parts.



# THE MOTHERBOARD & WIRING

## PARTS LOCATION

Now you will attach the Motherboard and begin the Wiring for the Lights of your model NISSAN GT-R (R35).



## PARTS LIST

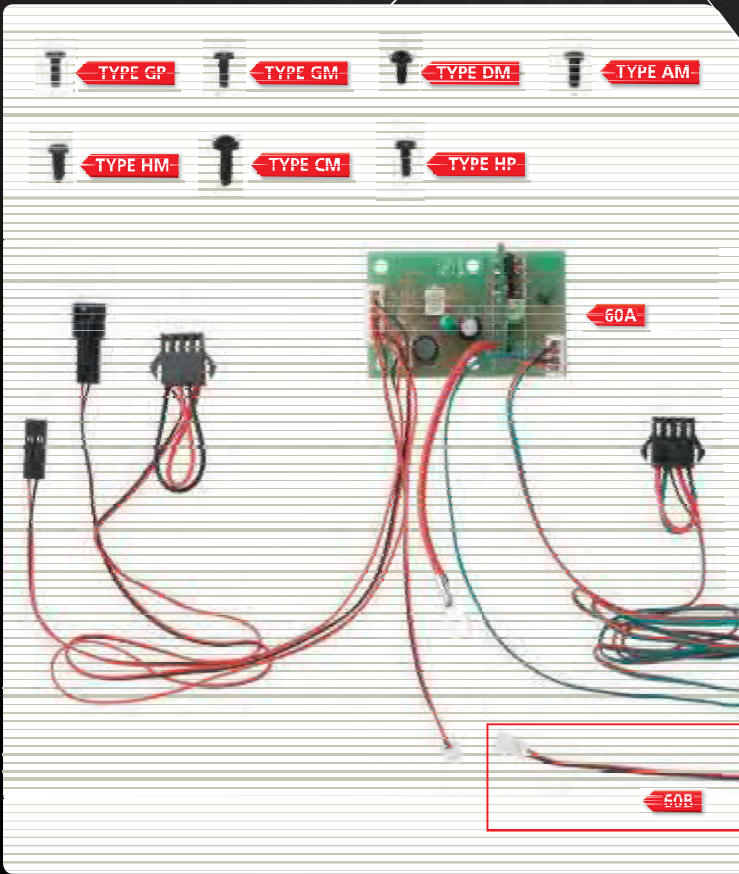

## PART IDENTIFICATION LIST

PART No.	NAME	QUANTITY	MATERIAL
60A	Motherboard	1	PCB
60B	Brake Pedal Switch	1	Nylon
60C	Brake Pedal Switch Base	1	ABS
60D	Gasket	4	ABS
60E	Wire Clip	9	ABS
60F	Insulating Paper	1	EVA
Screws	Type GP 0.08 x 0.16"	2 [+2 spare]	Metal [2 x 4mm]
Screws	Type GM 0.08 x 0.16"	4 [+2 spare]	Metal [2 x 4mm]
Screws	Type DM 0.08 x 0.12"	9 [+4 spare]	Metal [2 x 3mm]
Screws	Type AM 0.1 x 0.16"	4 [+2 spare]	Metal [2.6 x 4mm]
Screws	Type HM 0.09 x 0.16"	4 [+2 spare]	Metal [2.3 x 4mm]
Screws	Type CM 0.1 x 0.2"	2 [+2 spare]	Metal [2.6 x 6mm]
Screws	Type HP 0.09 x 0.16"	8 [+3 spare]	Metal [2.3 x 4mm]

## STEP 01 Attach the Insulating Paper

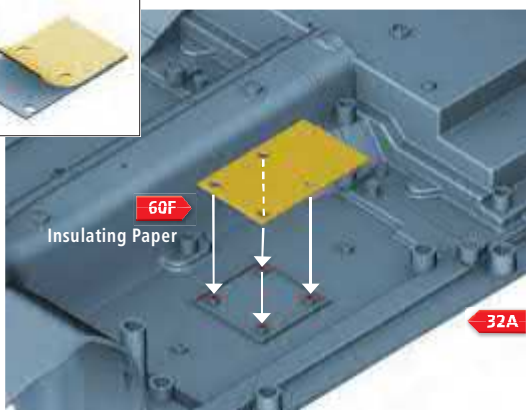

Unpeel the backing on the Insulating Paper [60F] to reveal its sticky side – see inset picture (far left). Now, place the Insulating Paper sticky side down on the top side of the Front Chassis [32A] (which came with Magazine 9) in the area indicated in the illustration.

32A Front Chassis

### COLOR KEY

- PART BEING FITTED
- PART BEING FITTED TO
- FIXINGS



## STEP 02 Position the Gaskets

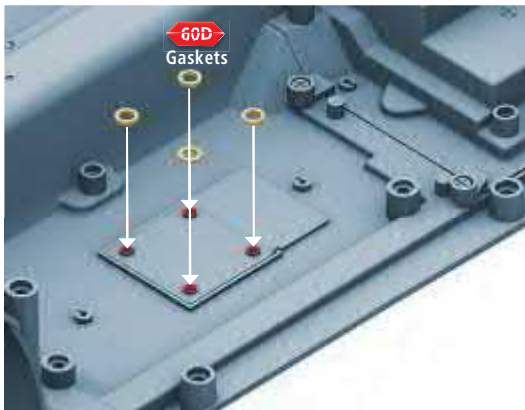

Position the four Gaskets [60D] over the four pegs that are protruding through the holes in the Insulating Paper [60F], as indicated in the illustration.



## STEP 03 Connect the Brake Pedal Switch to the Motherboard

Insert the Connector at the end of the Wire leading from the Motherboard [60A], shown in the illustration, into the Socket at the end of the Brake Pedal Switch [60B]. Ensure that you insert the Connector the correct way round, so that you don't damage the Prongs inside the Socket.

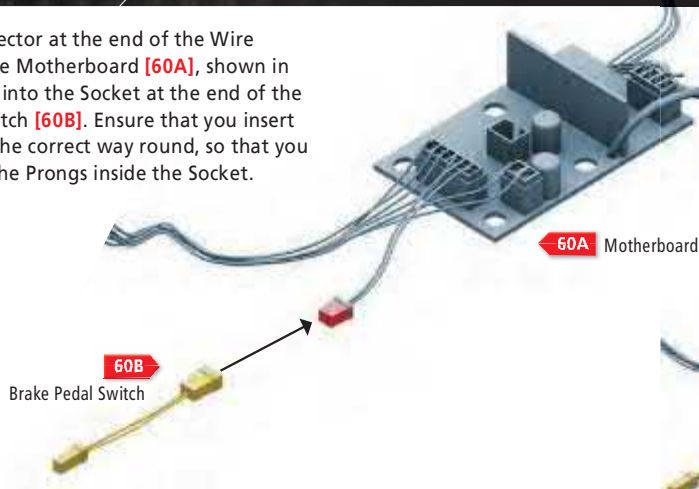

60A Motherboard

60B Brake Pedal Switch



## STEP 04 Attach the Motherboard

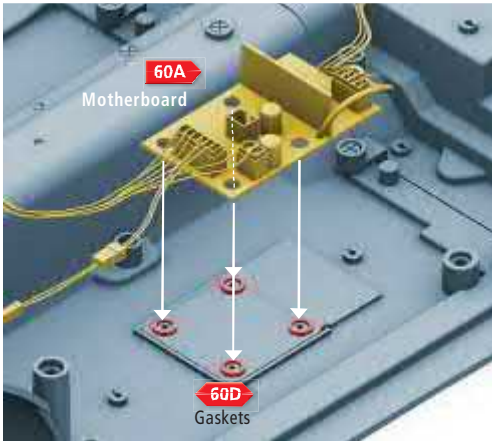

Place the Motherboard [60A] onto the Front Chassis [32A], so that the four holes in the Motherboard line up with the four Gaskets [60D]. Ensure that you put the Motherboard on the correct way round, so that it fully covers the Insulating Paper.



## STEP 05 Secure the Motherboard

Secure the Motherboard [60A] to the Front Chassis [32A] by using four TYPE GM screws in the holes indicated in the illustration.

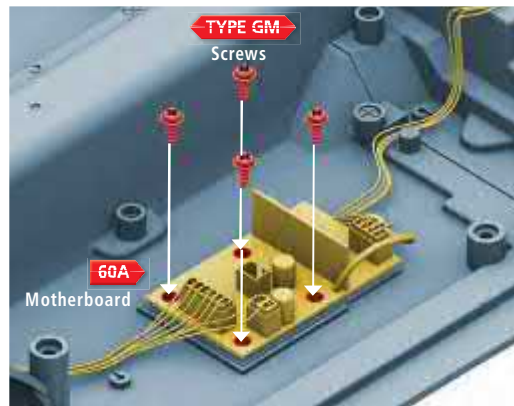

## STEP 06 Connect the ON/OFF Switch with Cable to the Motherboard

Insert the Connector at the end of the ON/OFF Switch with Cable [39C] into the Socket on the Motherboard [60A], marked by the white arrow in the illustration. Ensure that you place the Connector in the Socket the correct way round, so that you don't damage the Prongs inside the Socket.

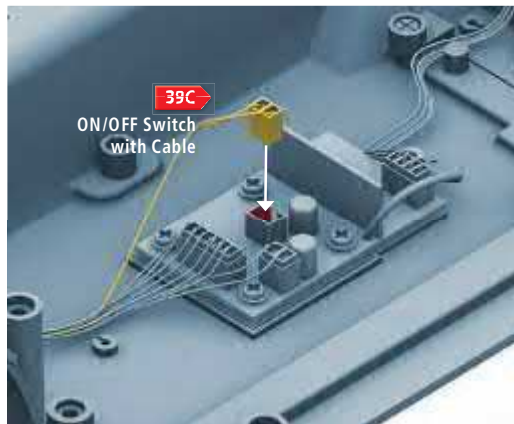



## STEP 07 Secure the thick red wire

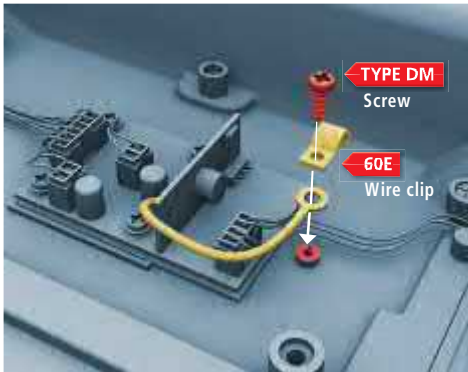

Place the metal ring at the end of the thick red wire over the hole indicated in the illustration. Now, secure it in place using a **TYPE DM** screw through a **Wire Clip [60E]**, while also using the Wire Clip to hold the wires that protrude from the back of the Motherboard **[60A]** neatly together.



## STEP 08 Attach the Wire Clips

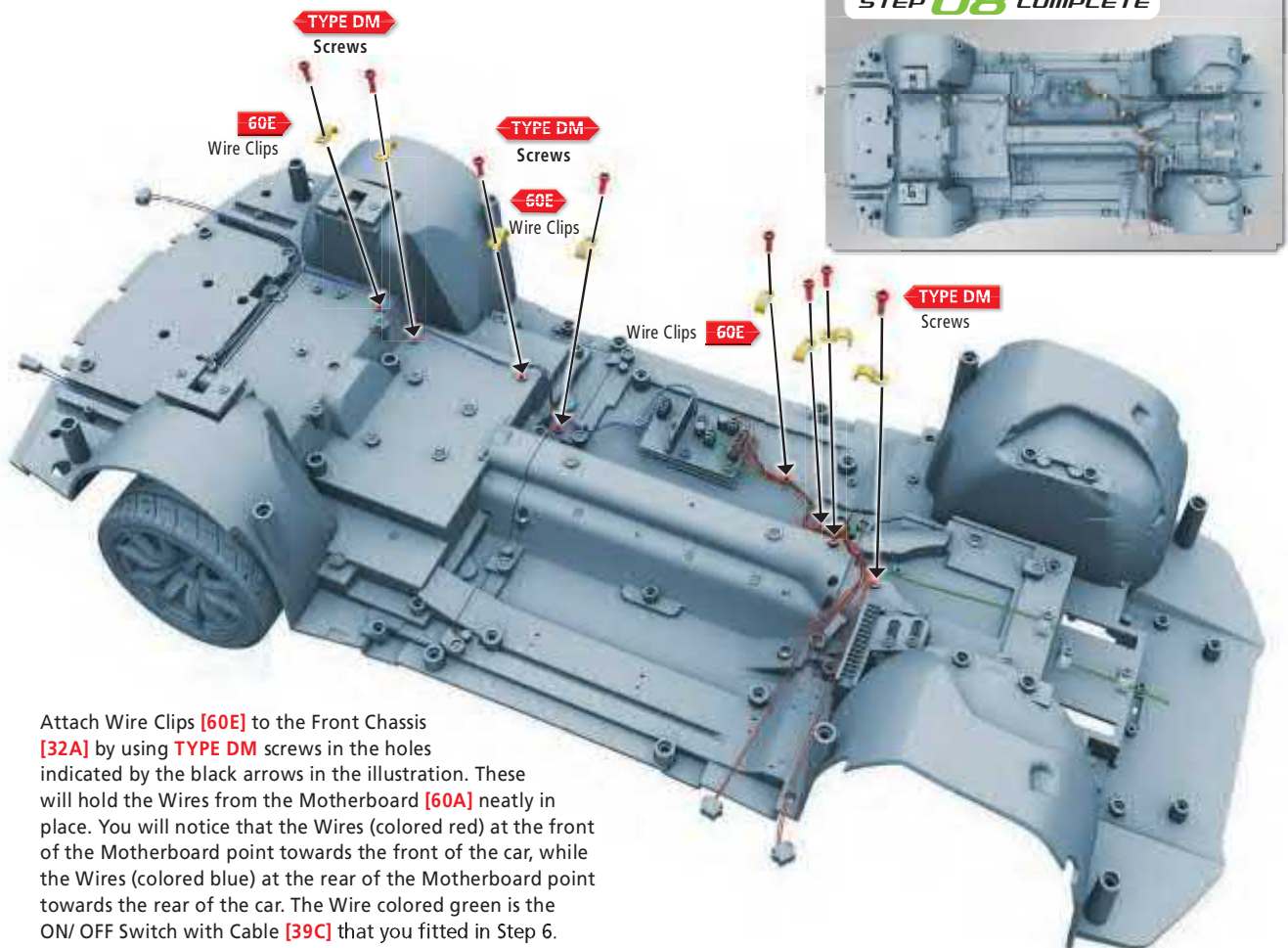

Attach Wire Clips **[60E]** to the Front Chassis **[32A]** by using **TYPE DM** screws in the holes indicated by the black arrows in the illustration. These will hold the Wires from the Motherboard **[60A]** neatly in place. You will notice that the Wires (colored red) at the front of the Motherboard point towards the front of the car, while the Wires (colored blue) at the rear of the Motherboard point towards the rear of the car. The Wire colored green is the ON/ OFF Switch with Cable **[39C]** that you fitted in Step 6.

## STEP 09

### Attach the Brake Pedal Switch Base

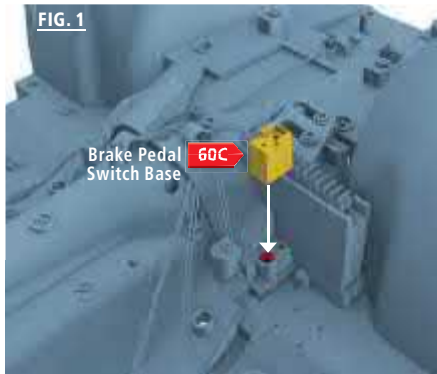

Place the Brake Pedal Switch Base [60C] onto the Front Chassis [32A] in the area shown in FIG.1. Turn the Front Chassis over and secure it in place with a TYPE GP screw, as shown in FIG.2.



## STEP 10

### Attach the Brake Pedal Switch

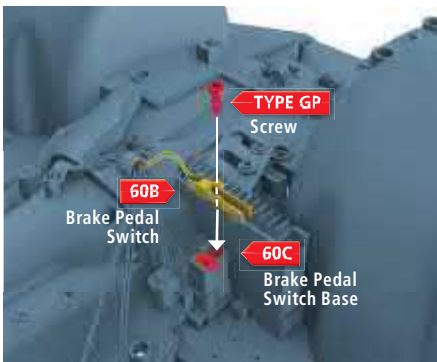

Insert the Brake Pedal Switch [60B] into the top of the Brake Pedal Switch Base [60C] and secure it in place with a TYPE GP screw from above, as shown in the illustration.



## Complete!

### The Motherboard

This is how the Wiring from the Motherboard should look once you have completed this section.

#### TIP!

Keep the AM, HM, CM and HP screws safe, as they will be used later.

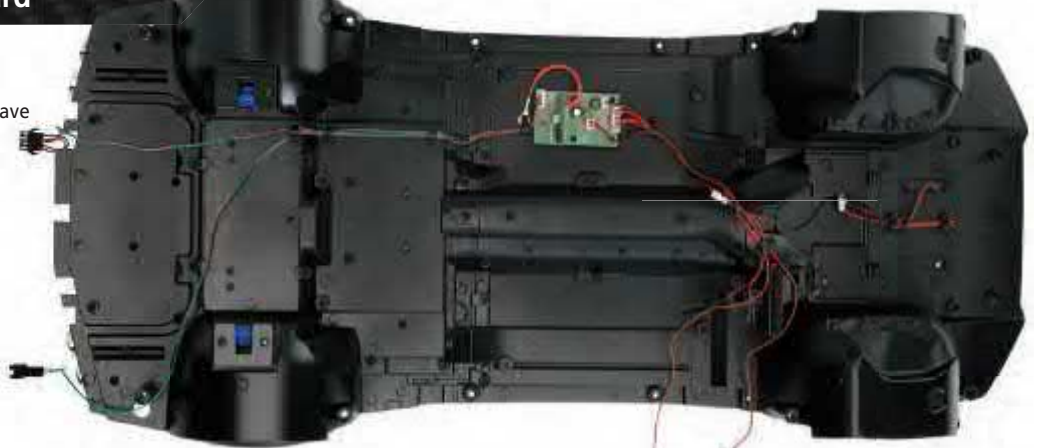

## TEST THE LIGHTS

Now you will test that all the Lights on your NISSAN GT-R (R35) model are working. You will need three 'AAA' Batteries (not supplied) for this section of the build.

### PARTS LOCATION

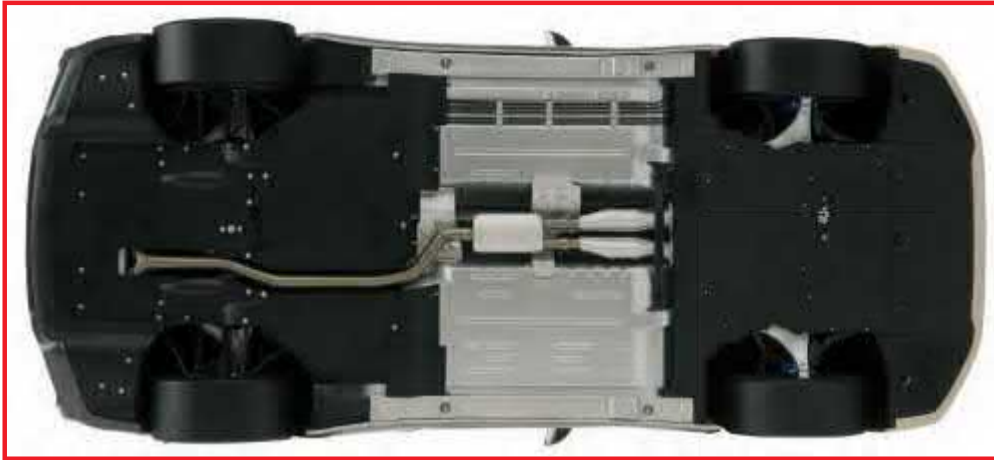

### PARTS LIST

#### PART IDENTIFICATION LIST

PART No.	NAME	QUANTITY	MATERIAL
61A	Key Controller	1	ABS
61B	Interior Light Switch	1	Nylon
61C	Headlights	1	LED
61D	Interior Light	1	LED
61E	Brake Lights	1	LED

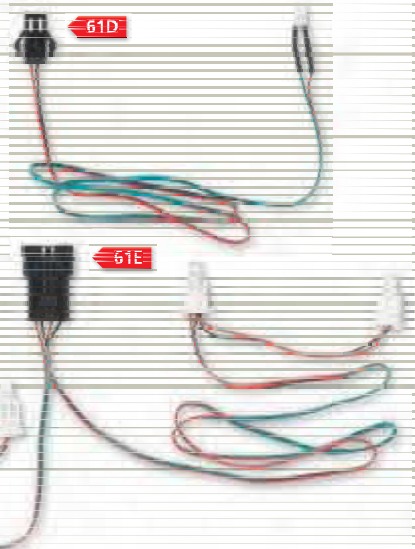

#### TIP!

These Lights will be fitted temporarily to check that they work, before removing them and continuing to build your model.

## STEP 01 Attach the Interior Light Switch



Insert the two-hole connector on the Interior Light Switch [61B] into the two-Prong Connector from the Motherboard that is shown in the illustration. Ensure that you don't damage the Prongs, but check that the two Connectors are fully pressed together.



## STEP 02 Attach the Headlights

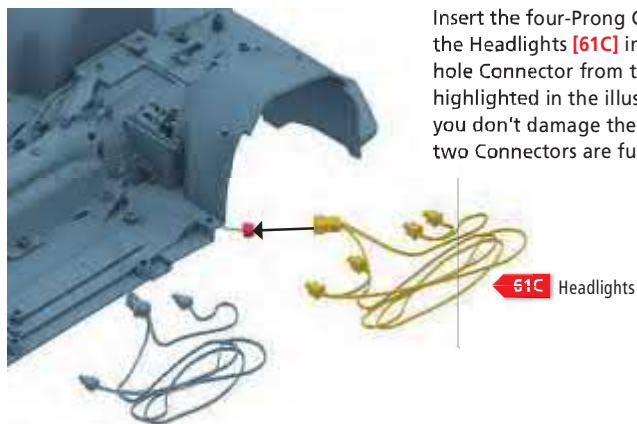

Insert the four-Prong Connector on the Headlights [61C] into the four-hole Connector from the Motherboard, highlighted in the illustration. Ensure that you don't damage the Prongs and that the two Connectors are fully pressed together.



## STEP 03 Attach the Brake Lights

Insert the four-Prong Connector on the Brake Lights [61E] into the four-hole Connector from the Motherboard that is running off the Rear Chassis [31A] (which came with Magazine 9), as shown in the illustration.

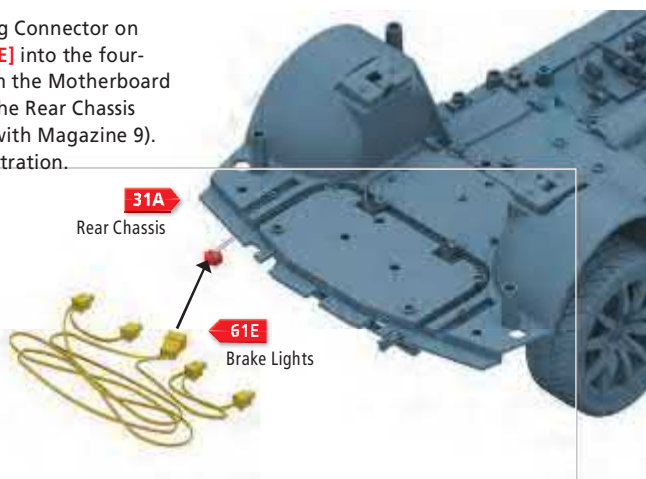

## STEP 04 Attach the Interior Light

31A  
Rear Chassis



Insert the two-hole Connector on the Interior Light [61D] into the two-prong Connector from the Motherboard that is running off the back of the Rear Chassis [31A]. Again, ensure that you don't damage the Prongs, but check that the two Connectors are fully pressed together.

STEP 04 COMPLETE



## STEP 05 Attach the Instrument Indicator

FROM PAGE 14  
Combined parts

Dashboard 54A

54D Instrument Indicator

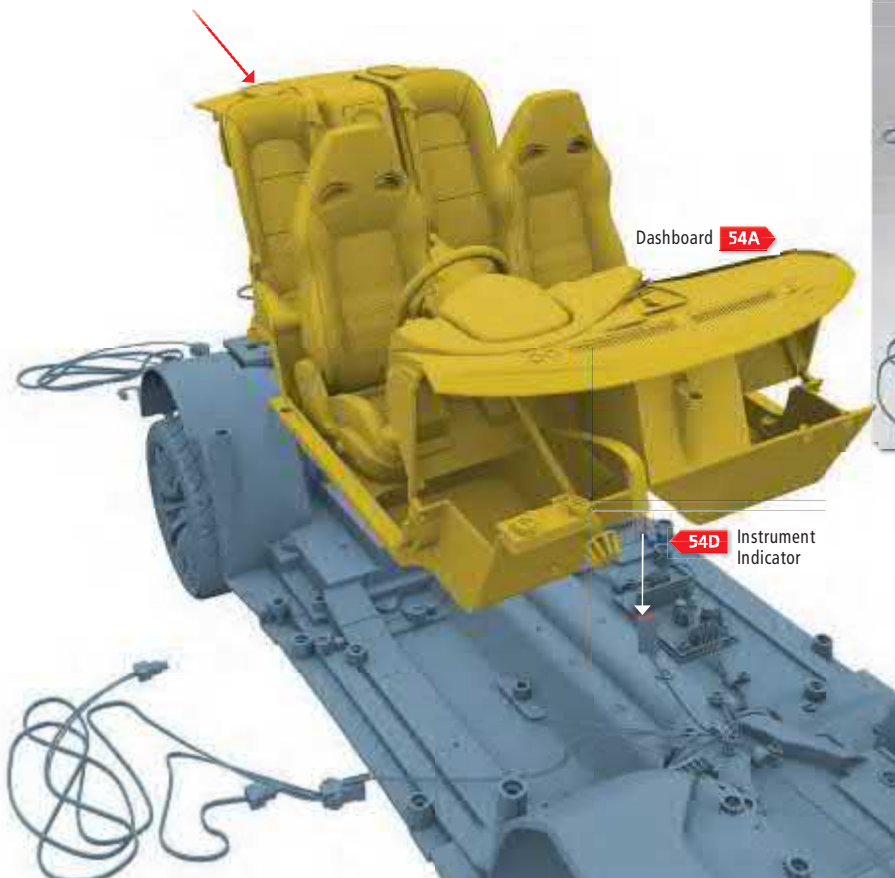

STEP 05 COMPLETE



Take the entire car interior that you completed on page 14 and plug the two-Pronged Connector from the Instrument Indicator [54D] (which came with Magazine 14), that is running out of the back of the Dashboard [54A], into the two-holed Connector from the Motherboard, highlighted in the illustration.

## STEP 06

### Take off the Battery Cover

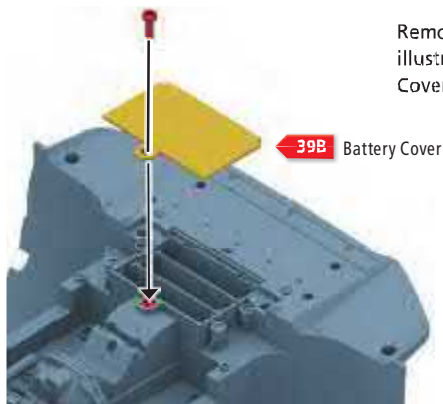

Remove the screw, as shown in the illustration, and take off the Battery Cover [39B] (which came with Magazine 11).

#### TIP!

Be careful not to misplace the screw, as you'll need to replace the Battery Cover later.

### STEP 06 COMPLETE



## STEP 07

### Insert three 'AAA' Batteries

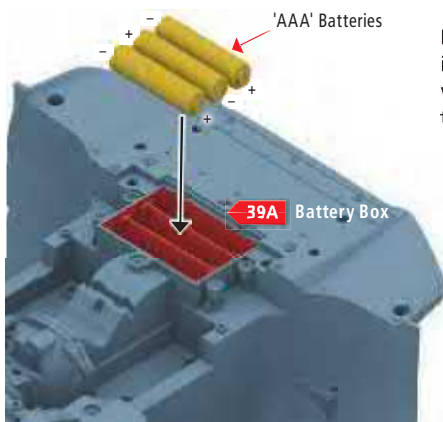

Insert three 'AAA' Batteries (not supplied) into the Battery Box [39A] (which came with Magazine 11), as shown in the illustration.

### STEP 07 COMPLETE



## STEP 08

### Turn the electrics on



Once the Batteries are inserted, flick across the ON/ OFF Switch with Cable [39C], located above the Battery Box [39A], as shown in the illustration. This turns the electrics on.

### STEP 08 COMPLETE



## STEP 09 Turn the Instrument Indicator Light on the Dashboard on

Press the middle button on the Key Controller [61A], highlighted in yellow on the illustration, and the Instrument Indicator [54D] on the Dashboard will light up. Press the bottom button on the Key Controller and the Instrument Indicator Light will go off.



## STEP 10 Turn the Interior Light on

Press the buttons on the Interior Light Switch [61B], highlighted by the black arrow in the illustration on the left, and the Interior Light [61D], shown in the illustration on the right, will come on. Let go of the button and the light will go off.

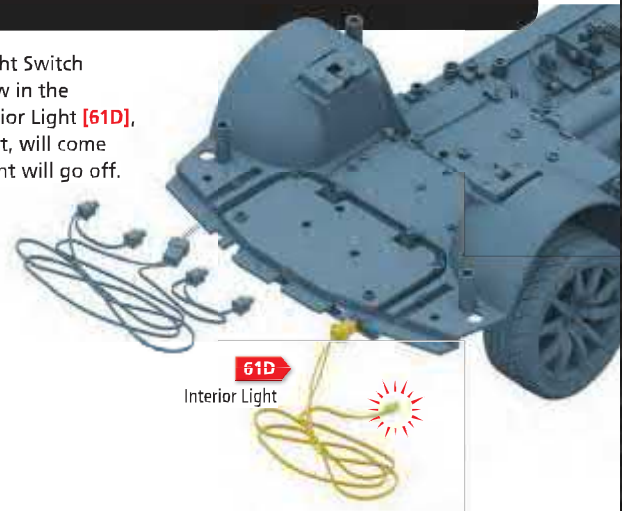
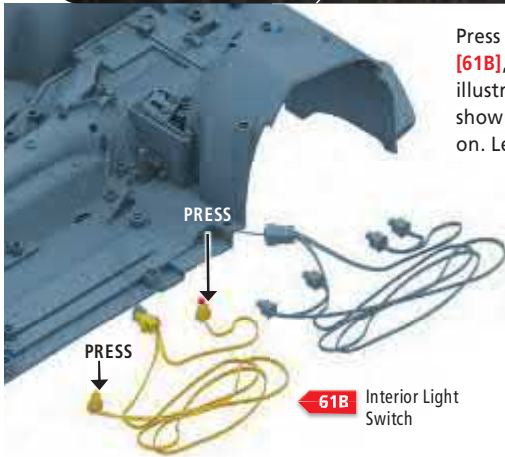

## STEP 11 Turn the Brake Light on

Press the contact on the Brake Pedal Switch [60B] together, as shown in the illustration on the left, and the Brake Lights [61E], shown in the illustration on the right, will come on. Let go of the contact on the Brake Pedal Switch and the lights will go out.

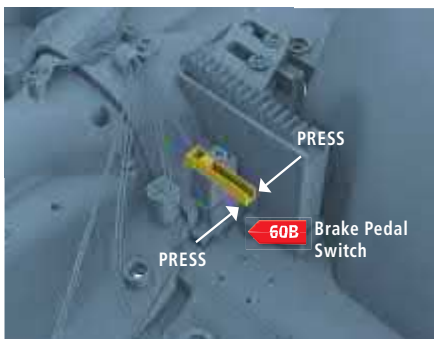

## STEP 12

### Turn the Headlights on

Press the top button on the Key Controller [61A], highlighted in yellow on the illustration, and the Headlights [61C] will come on. Press the bottom button on the Key Controller and the Headlights will go off.

61A  
Key Controller



61C Headlights

## Complete!

### Testing the Lights



This is how your model should look with all the Lights correctly wired up, so that you can test them.

#### TIP!

Once you have tested that the Lights work, you must disconnect them all, so that you can continue building your model.

### HOW TO CHANGE THE BATTERY



Remove the three screws to open the remote-control fob casing.



Pull out the circuit board to reveal the battery compartment underneath.



Push the expired battery out of the battery compartment and dispose of it safely.



Insert two new CR2016 batteries, then refit the circuit board and the three screws.



## ASSEMBLE MULTIPLE PARTS

Next, you will add multiple parts – from this and previous magazines – to the Chassis of your NISSAN GT-R (R35) model, including the Engine, Radiator, Intercooler, Front Wheels and the Car Trunk.

### PARTS LOCATION



### PARTS LIST

62A →

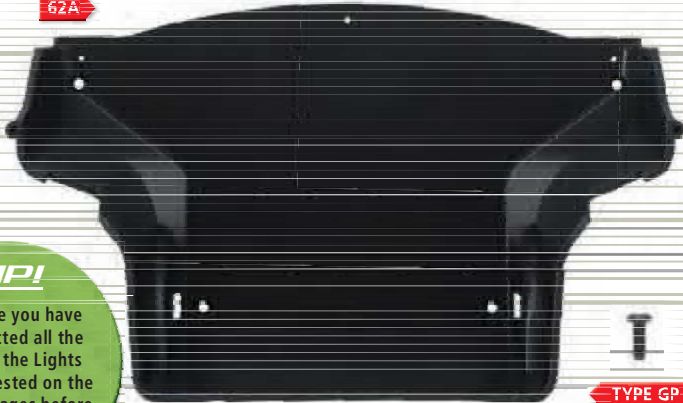

PART No.	NAME	QUANTITY	MATERIAL
62A	Car Trunk	1	ABS
62B	Car Trunk Board	1	ABS
Screws	Type GP 0.08 x 0.16" [2 x 4mm]	2 [+1 spare]	Metal
Screws	Type GM 0.08 x 0.16" [2 x 4mm]	4 [+1 spare]	Metal
Screws	Type CP 0.1 x 0.2" [2.6 x 6mm]	6 [+2 spare]	Metal
Screws	Type HP 0.1 x 0.16" [2.3 x 4mm]	2 [+1 spare]	Metal
Screws	Type SM 0.1 x 0.35" [2.6 x 9 mm]	2 [+1 spare]	Metal



#### TIP!

Make sure you have disconnected all the Wires for the Lights that you tested on the previous pages before starting this section.

62B →



#### YOU WILL ALSO NEED:

- Radiator you received with ..... Magazine 03
- Completed Intercooler from ..... Magazine 03
- Front Diffuser Panel you received with ..... Magazine 04
- Completed Engine from ..... Magazine 05
- Completed Front Left Wheel from ..... Magazine 11
- Completed Front Suspension System from ..... Magazine 14
- Washers you received with ..... Magazine 14
- Completed Front Right Wheel from ..... Magazine 14
- Completed Interior from ..... Magazine 16

## STEP 01

### Attach the Engine

FIG. 1

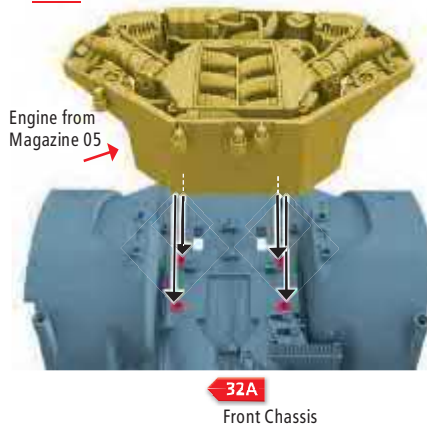

Take the Engine from Magazine 05 and position it on the Front Chassis [32A], as shown in FIG.1. Secure it from underneath using four TYPE HP screws you received with this magazine, as shown in FIG.2.

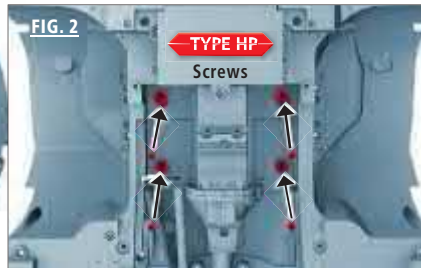

#### COLOR KEY

- PART BEING FITTED
- PART BEING FITTED TO
- FIXINGS

### STEP 01 COMPLETE



## STEP 02

### Attach the Radiator

FIG. 1

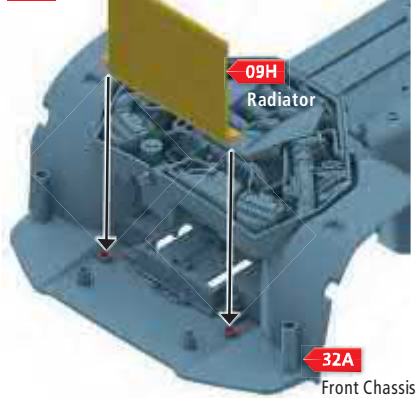

Take the Radiator [09H] that you received with Magazine 03 and insert its struts in the holes shown in FIG.1. Secure it in place from underneath the Front Chassis [32A] with two TYPE HP screws that you received with Magazine 03, as shown in FIG.2.

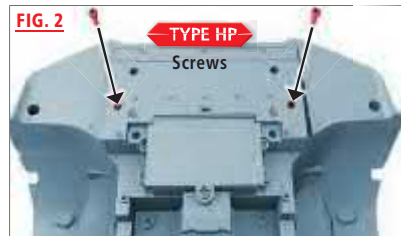

### STEP 02 COMPLETE



## STEP 03

### Attach the Intercooler and Intercooler Base

FIG. 1

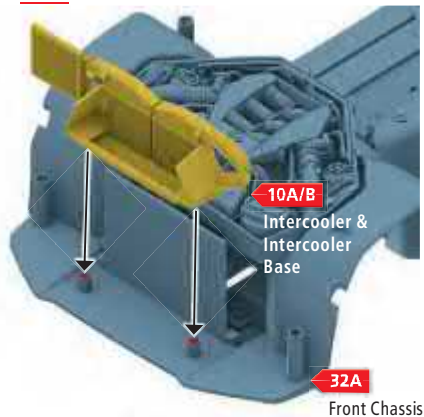

Take the combined Intercooler [10A/B] that you built in Magazine 03 and insert its struts in the holes shown in FIG.1. Secure it in place from underneath the Front Chassis [32A] with two TYPE HP screws that you received with Magazine 03, as shown in FIG.2.

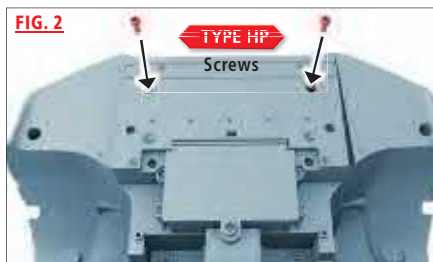

### STEP 03 COMPLETE



## STEP 04 Attach the Front Suspension System

Take the Front Suspension System that you completed in Magazine 14 and position it over the four holes in the bottom of the Front Chassis [32A], as shown in the illustration. Secure it in place with four **TYPE AM** screws that you received with this magazine.

**32A**  
Front Chassis

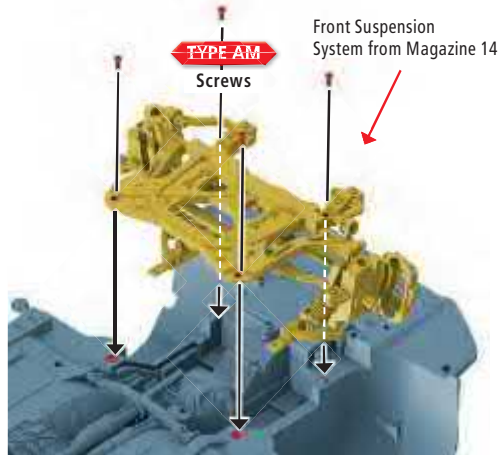

## STEP 05 Secure the Front Suspension System

Complete the attachment of the Front Suspension System to the Front Chassis by using two **TYPE HM** screws that you received with this magazine through the two holes in the Upper Swing Arm Base [48A], as indicated in the illustration.

**32A**  
Front Chassis

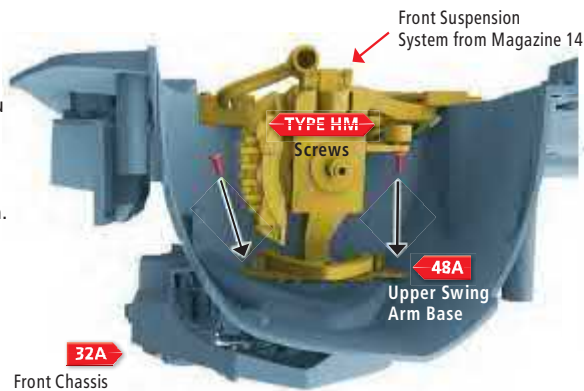

## STEP 06 Add the Washers and the Brake Discs

Push the two Washers you received with Magazine 14 over the Knuckle Base [47D], as shown in the illustration, followed by the Combined Brake Disc that you assembled in Magazine 13. Now, do the same on the other side – the other Combined Brake Disc was assembled in Magazine 12.

**32A**  
Front Chassis

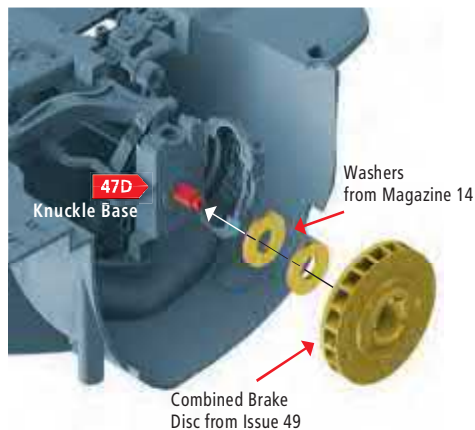

## STEP 07 Attach the Combined Front Wheels

Slide the center hole of the Combined Left Front Wheel from Magazine 11 onto the peg of the Knuckle Base [42D], as shown in the illustration, and secure it with a **TYPE CM** screw before adding the Wheel Cap [40B]. Do the same on the other side with the Right Front Wheel parts you received with Magazine 14.

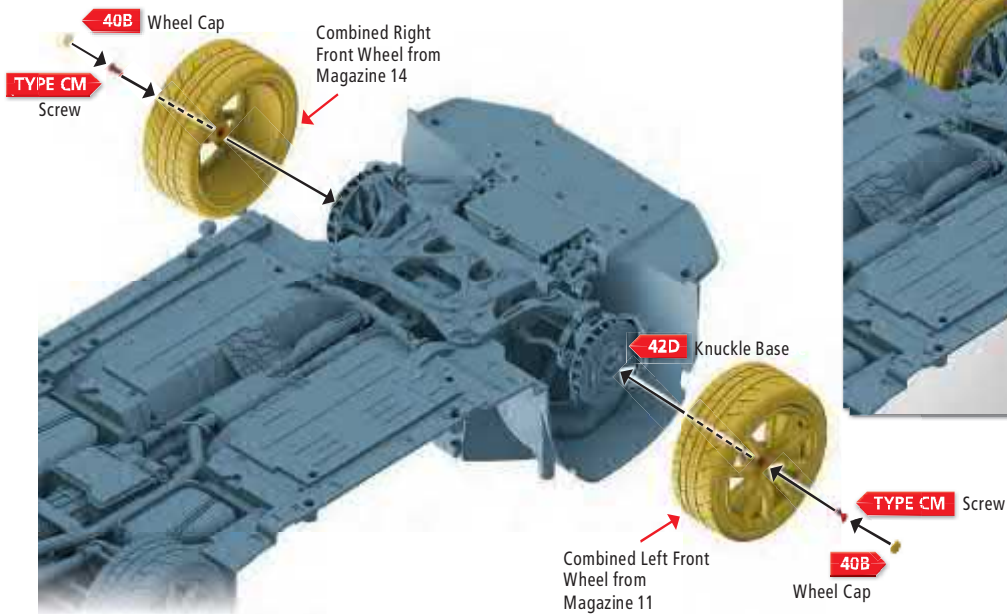

## STEP 08 Attach the Front Diffuser Panel

FIG. 1

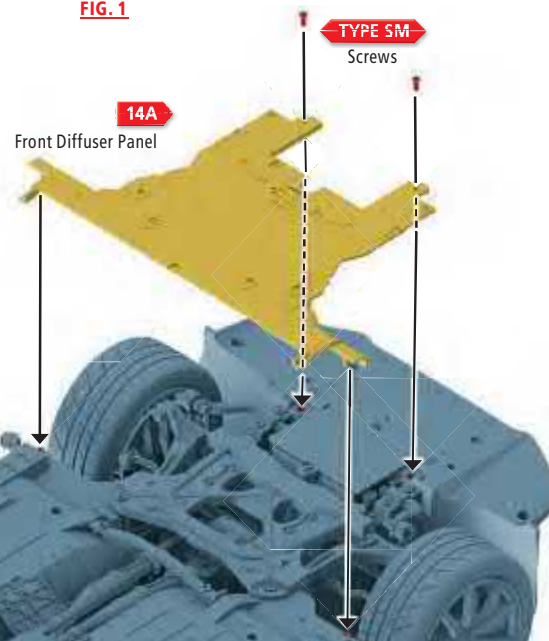

Take the Front Diffuser Panel [14A] you received with Magazine 04 and position it on the underside of the Front Chassis [32A], as shown in FIG.1. Secure it from the underside with two **TYPE SM** screws in the holes shown in FIG.1 before turning the chassis over and using two **TYPE HP** screws in the holes shown in FIG.2 to finish securing the Front Diffuser Panel in place.

FIG. 2

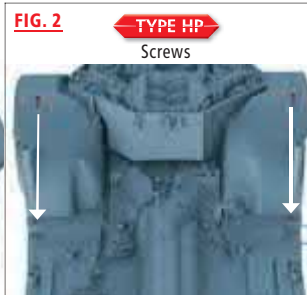

## STEP 09 Attach the Car Trunk

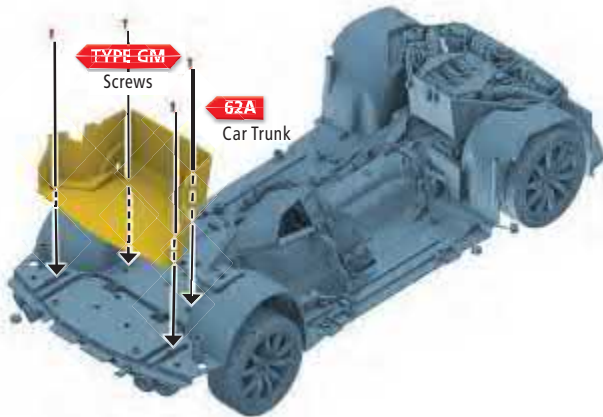

Line up the four holes in the Car Trunk [62A] with the four small struts on the Rear Chassis [31A], as shown in the illustration, and secure it in place with four TYPE GM screws from above.



## STEP 10 Attach the Car Trunk Board

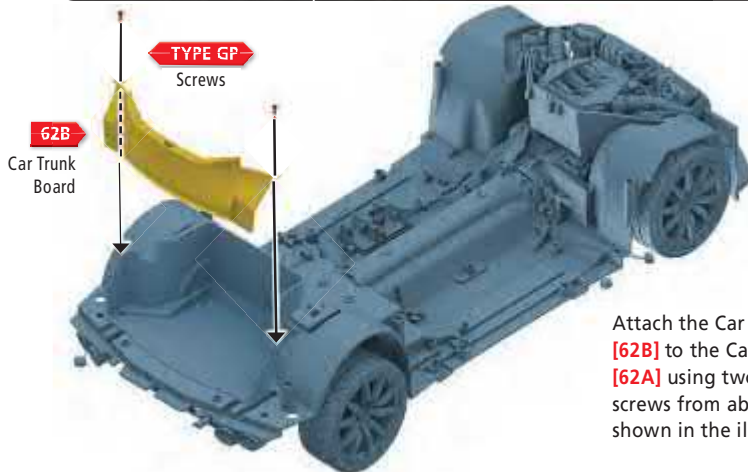

Attach the Car Trunk Board [62B] to the Car Trunk [62A] using two TYPE GP screws from above, as shown in the illustration.



## STEP 11 Attach the Instrument Indicator Panel



Take the entire car Interior that you completed earlier in this magazine and plug the two-Pronged Connector from the Instrument Indicator [54D] into the two-holed Connector from the Motherboard, as highlighted in the illustration.



## STEP 12

### Attach the Combined Interior to the Chassis

FIG. 1

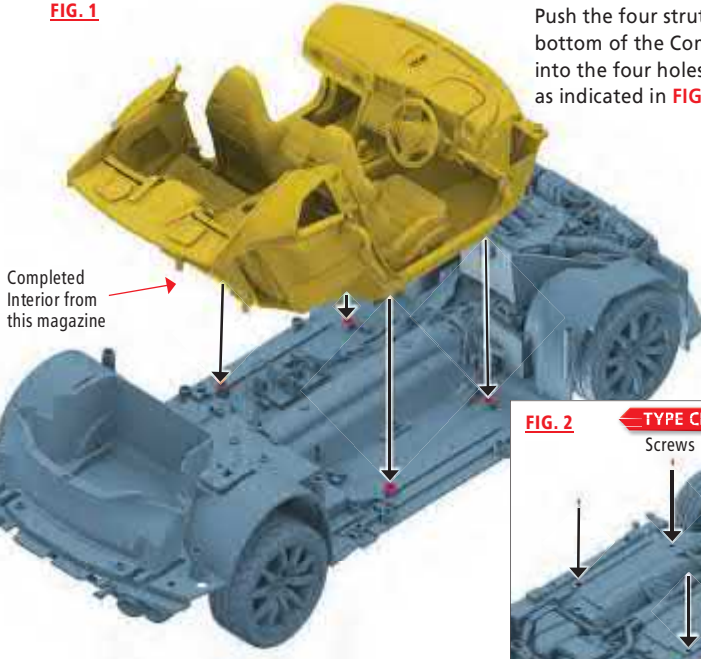

Push the four struts on the bottom of the Combined Interior into the four holes in the Chassis, as indicated in FIG.1.

## STEP 12 COMPLETE



FIG. 2

TYPE CP  
Screws

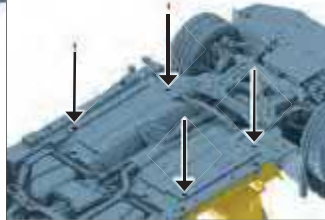

Now, turn the Chassis over and secure the Interior to the Chassis with four **TYPE CP** screws, as shown in FIG.2.



## Complete!

### Multiple parts added

This is how your NISSAN GT-R (R35) model should look once you have assembled all of the parts in this section of the build.

## THE FRONT BODY

In this magazine, you will attach the Side Vents to the Front Body of your NISSAN GT-R (R35) model.

### PARTS LOCATION

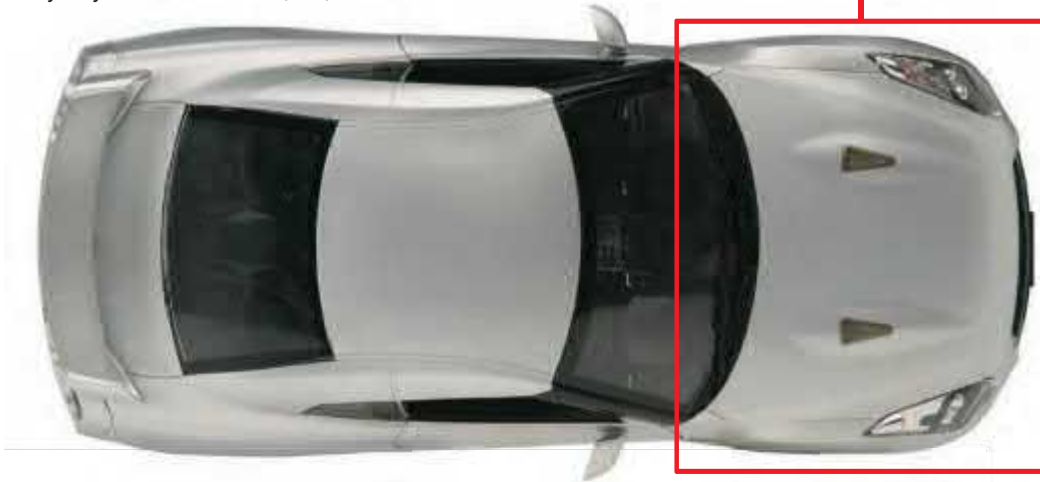

### PARTS LIST

#### PART IDENTIFICATION LIST

PART No.	NAME	QUANTITY	MATERIAL
63A	Front Body	1	Zinc
63B	Right Side Vent	1	ABS
63C	Left Side Vent	1	ABS
Screws	Type MP 0.6 x 0.16" [1.7 x 4mm]	6+[2 spare]	Metal



## STEP 01

### Remove the metal supports

Unscrew the two metal supports, as indicated in the illustration, and remove them. These metal supports are only used to help the Front Body [63A] retain its shape during transit and can be disposed of once you have taken them off.

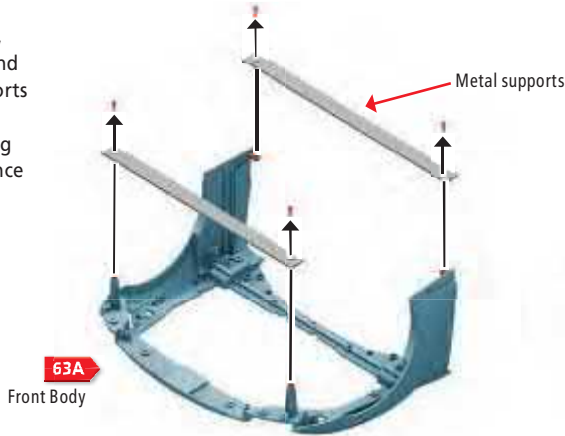

#### COLOR KEY

- PART BEING FITTED
- PART BEING FITTED TO
- FIXINGS

### STEP 01 COMPLETE



## STEP 02

### Attach the Side Vents

Place the Right Side Vent [63B] into the area of the Front Body [63A] indicated in FIG.1. From the other side of the Front Body, use three TYPE MP screws to secure the Right Side Vent in place, as shown in FIG.2. Repeat the process for the Left Side Vent [63C] on the other side.

FIG. 1

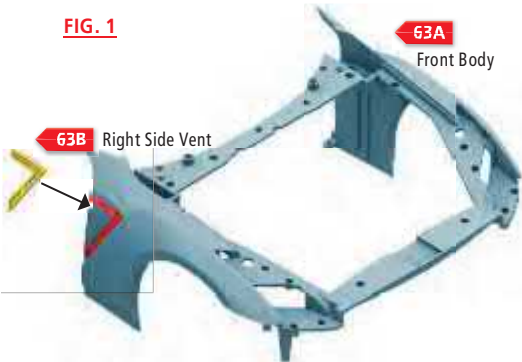
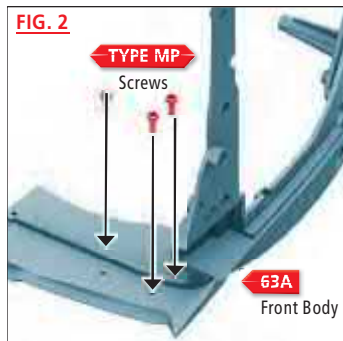

FIG. 2



### STEP 02 COMPLETE



## Complete!

### The Front Body

This is how the Front Body should look once you have attached the Side Vents.





## THE REAR BODY

Now you will combine the Rear and Front Bodies of your NISSAN GT-R (R35) model.

### PARTS LOCATION



### PARTS LIST

#### PART IDENTIFICATION LIST

PART No.	NAME	QUANTITY	MATERIAL
<b>64A</b>	Rear Body	1	Zinc
<b>Screws</b>	Type AM 0.1 x 0.16" [2.6 x 4mm]	4 [+1 spare]	Metal
<b>Screws</b>	Type CM 0.1 x 0.2" [2.6 x 6mm]	2 [+1 spare]	Metal



ALSO WITH THIS MAGAZINE:  
0.08" (2mm) PHILLIPS-HEAD  
SCREWDRIVER



## STEP 01

### Remove the metal supports

Unscrew the three metal supports, as indicated in the illustration, and remove them. These metal supports are only used to help the Rear Body [64A] retain its shape during transit and can be disposed of once you have taken them off.

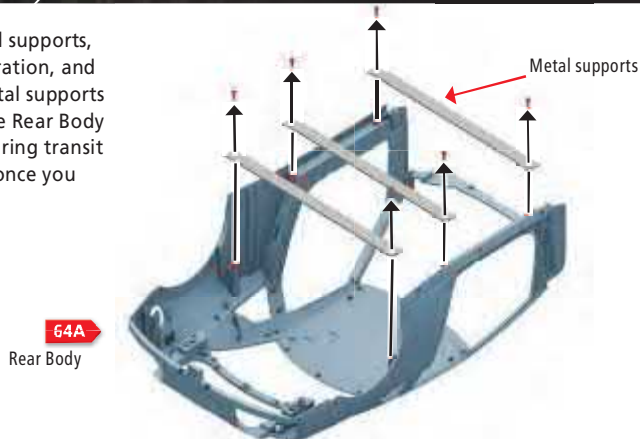

#### COLOR KEY

- PART BEING FITTED
- PART BEING FITTED TO
- FIXINGS

### STEP 01 COMPLETE



## STEP 02

### Attach the Rear Body to the Front Body

Push the Rear Body [64A] together with the Front Body [63A], as indicated in the illustration, so that all the screw holes on the two sections line up. You may find that you have to push them together quite hard to make the screw holes line up properly.

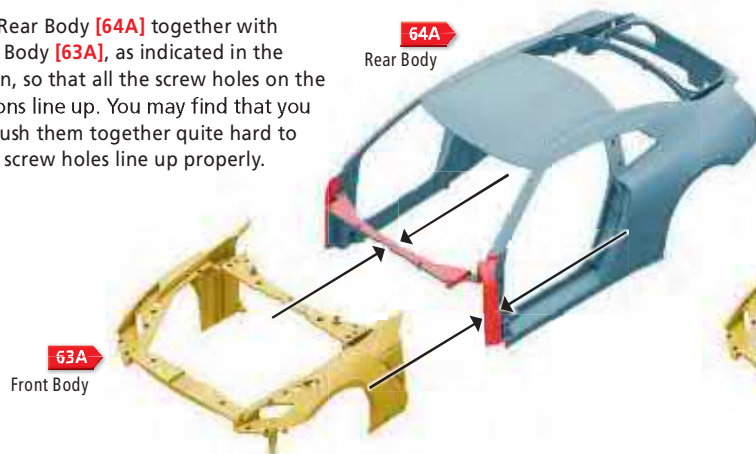

### STEP 02 COMPLETE



## STEP 03

### Secure the Rear Body to the Front Body

Secure the Rear Body [64A] to the Front Body [63A] by using four TYPE AM Screws from above in the holes indicated in the illustration.

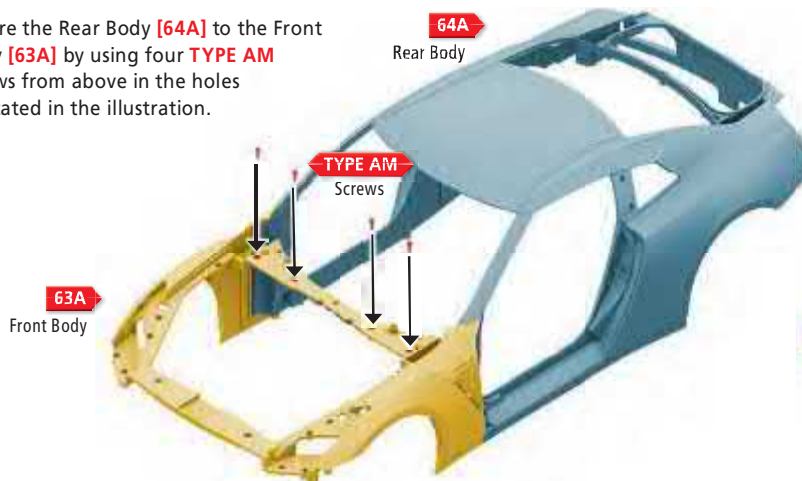

### STEP 03 COMPLETE



## STEP 04 Secure the Rear Body to the Front Body

Finish securing the Rear Body [64A] to the Front Body [63A] by using two TYPE CM screws in the holes indicated in the illustration.

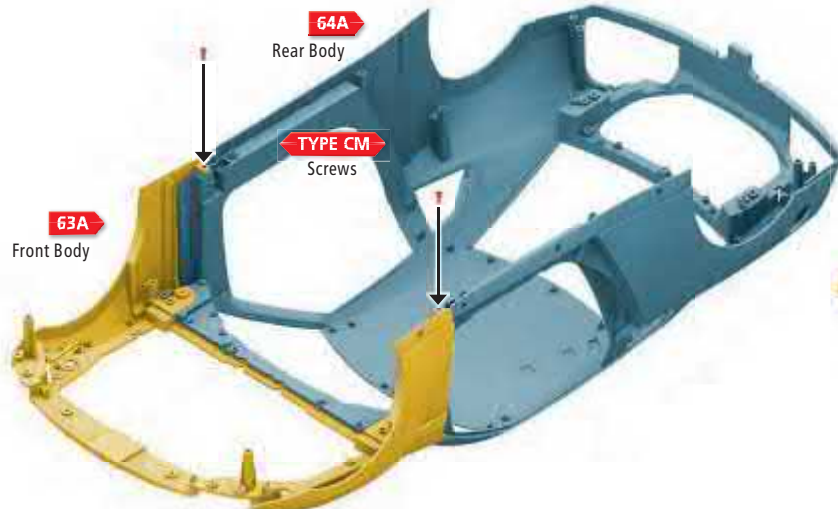

### Complete!

#### The Car Body

This is how your model should look once you have attached the two halves of the Car Body together.



# THE RIGHT SIDE SKIRT

Next, you will attach the Right Side Skirt to the Car Body of your NISSAN GT-R (R35) model.

## PARTS LOCATION



## PARTS LIST

### PART IDENTIFICATION LIST

PART No.	NAME	QUANTITY	MATERIAL
65A	Right Side Skirt	1	Zinc
65B	Interior Light Switch Clip	1	Fe
65C	Interior Light Switch Clip	1	Fe
65D	Wire Clip D	5 [+2 spare]	ABS
Screws	Type HM 0.09 x 0.16" [2.3 x 4mm]	4 [+1 spare]	Metal



65A



65B

65C

65D



TYPE HM

## STEP 01

### Attach the Right Side Skirt

#### COLOR KEY

- PART BEING FITTED
- PART BEING FITTED TO
- FIXINGS

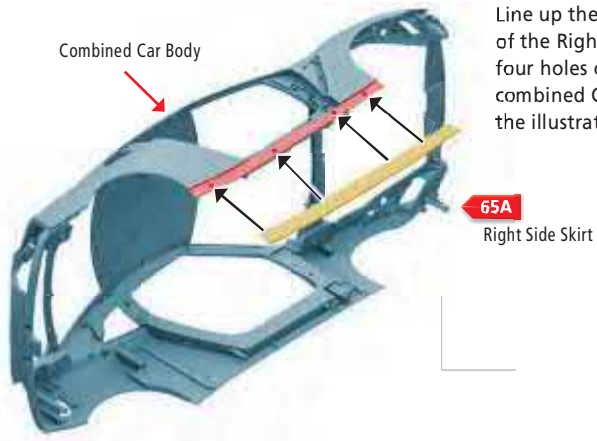

## STEP 02

### Secure the Right Side Skirt to the Car Body

Holding the Right Side Skirt [65A] in place, secure it to the Car Body from the other side with four **TYPE HM** screws in the holes indicated in the illustration.

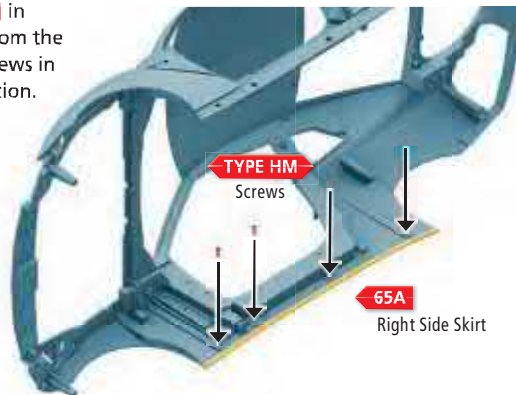

## Complete!

### The Car Body

This is how the exterior of the Car Body should look once you have attached the Right Side Skirt.

#### TIP!

Keep all the Clips that came with this magazine safe, as they will be used in a later build.



# THE LEFT SIDE SKIRT

Now you will attach the Left Side Skirt to the Car Body of your NISSAN GT-R (R35) model.

## PARTS LOCATION



## PARTS LIST

**TIP!**  
The Wire Clips are different sizes and have numbers on them to help you tell them apart.

### PART IDENTIFICATION LIST

PART No.	NAME	QUANTITY	MATERIAL
66A	Left Side Skirt	1	Zinc
66B	Wire Clip 3	2	ABS
66C	Wire Clip 4	2	ABS
66D	Wire Clip 5	2	ABS
66E	Wire Clip 6	2	ABS
Screws	Type HM 0.09 x 0.16"- [2.3 x 4mm]	4 [+1 spare]	Metal

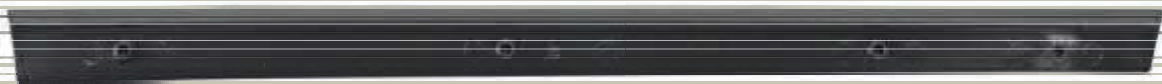

66A



## STEP 01 Attach the Left Side Skirt

Line up the four struts on the back of the Left Side Skirt [66A] with the four holes on the left side of the combined Car Body, as indicated in the illustration.

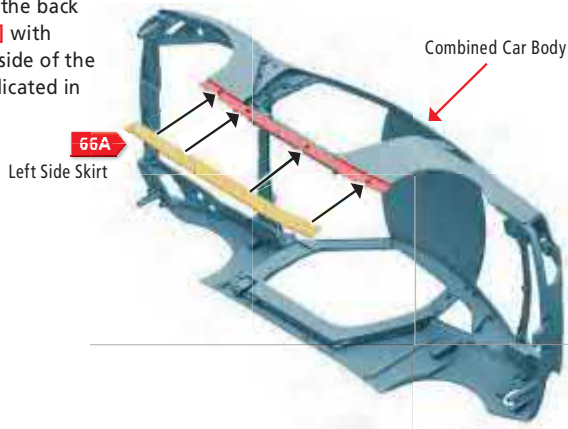

### COLOR KEY

- PART BEING FITTED
- PART BEING FITTED TO
- FIXINGS



## STEP 02 Secure the Left Side Skirt to the Car Body

Holding the Left Side Skirt [66A] in place, secure it to the Car Body from the other side with four TYPE HM screws in the holes indicated in the illustration.

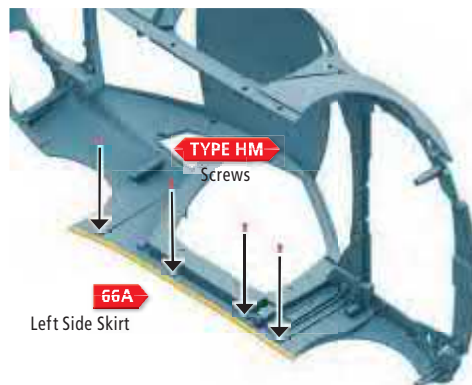

## Complete!

### The Left Side Skirt

This is how the exterior of the Car Body should look once you have attached the Left Side Skirt.

#### TIP!

Keep all the Clips that came with this magazine safe, as they will be used in a later build.







# HOW TO BUILD

## THE ENGINE BAY PANEL

In this magazine, you will attach the Engine Bay Panel and Hood Stand to your NISSAN GT-R (R35) model.

### PARTS LOCATION

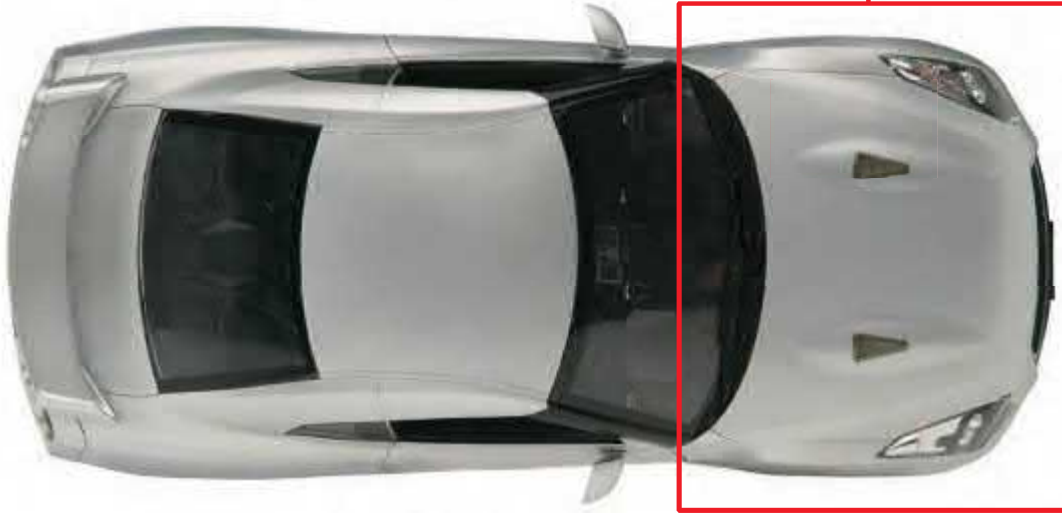

### PARTS LIST

#### PART IDENTIFICATION LIST

PART No.	NAME	QUANTITY	MATERIAL
67A	Engine Bay Panel	1	ABS
67B	Hood Stand	1	Stainless Steel
67C	Hood Opener Pin	1	ABS
Screws	Type GP 0.08 x 0.16" [2 x 4mm]	7 [+2 spare]	Metal
Screws	Type IM 0.06 x 0.18" [1.7 x 4.5mm]	1 [+1 spare]	Metal



## STEP 01

### Attach the Hood Opener Pin

Push the Hood Opener Pin [67C] through the hole in the underside of the Engine Bay Panel [67A], as shown in the illustration, and secure it in place with a TYPE GP screw.

#### COLOR KEY

- PART BEING FITTED
- PART BEING FITTED TO
- FIXINGS

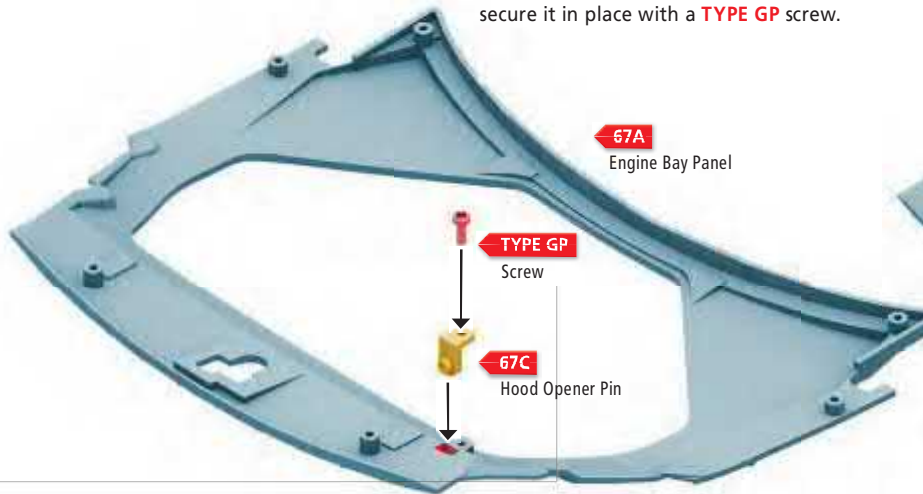

## STEP 02

### Attach the Hood Stand

From the top side of the Engine Bay Panel [67A], attach the Hood Stand [67B] by pushing a TYPE IM screw through the hole in the end of it and screwing it into the Hood Opener Pin [67C], as shown in the illustration.

#### STEP 02 COMPLETE

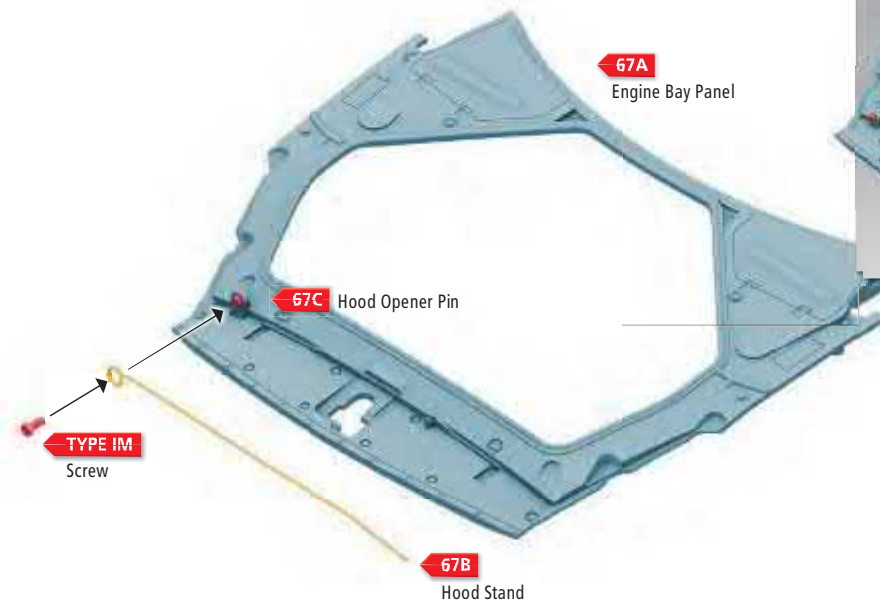

## STEP 03

### Attach the Engine Bay Panel to the Front Body

Attach the Engine Bay Panel [67A] to the Front Body [63A] by using six **TYPE GP** screws in the holes indicated in the illustration.

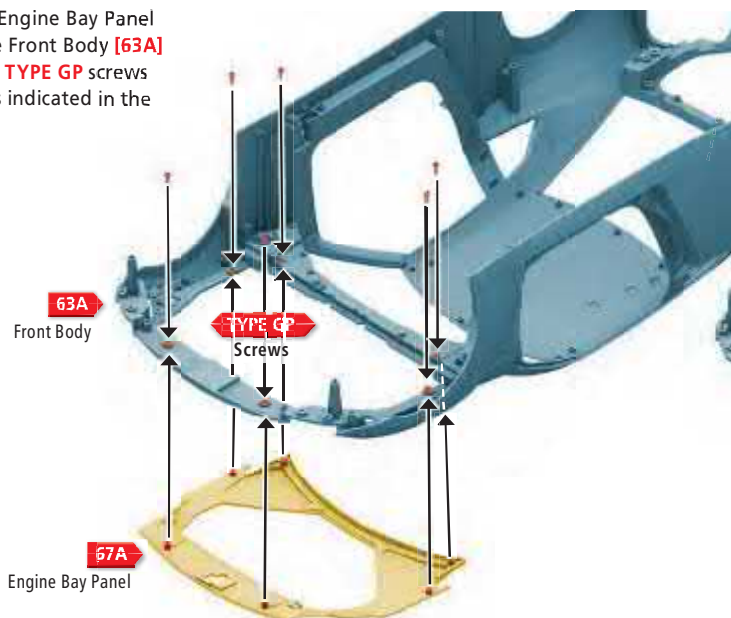

## Complete!

### The Engine Bay Panel

This is how your model should look once you have attached these parts to the car body.



# THE RIGHT HEADLIGHT

Now you will assemble and attach the Right Headlight on your NISSAN GT-R (R35) model.



## PARTS LIST

### PART IDENTIFICATION LIST

PART No.	NAME	QUANTITY	MATERIAL
68A	Right Headlight Cover	1	GP
68B	Right Headlight Holder	1	GP
68C	Right Headlight Base	1	ABS
68D	Headlight Lens	1	GP
68E	Sidelight Lens	1	GP
Screws	Type BP 0.06 x 0.12"	2 [+2 spare]	Metal [1.5 x 3mm]
Screws	Type GP 0.08 x 0.16"	4 [+2 spare]	Metal [2 x 4mm]



68A



68B



68C



TYPE BP



TYPE GP



68D



68E

## STEP 01 Attach the Headlight Lens

Insert the Headlight Lens [68D] into the larger of the two circular recesses of the Right Headlight Base [68C], as indicated in FIG.1. Make sure the Headlight Lens is firmly in place by gently tapping it down with a straw or a pen, as shown in FIG.2.

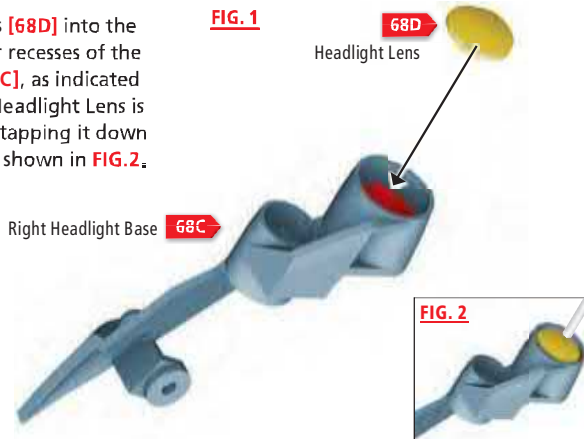

**COLOR KEY**  
■ PART BEING FITTED  
■ PART BEING FITTED TO  
■ FIXINGS



## STEP 02 Attach the Sidelight Lens

Insert the Sidelight Lens [68E] into the smaller of the two circular recesses of the Right Headlight Base [68C], as indicated in FIG.1. Make sure the Sidelight Lens is firmly in place by gently tapping it down with a straw or a pen, as shown in FIG.2.

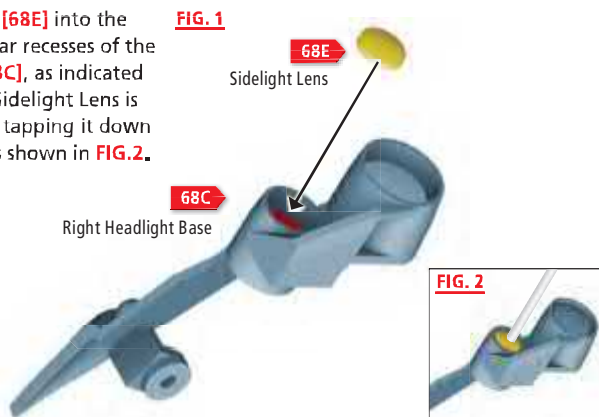

## STEP 03 Secure the Right Headlight Base to the Right Headlight Holder

Position the Right Headlight Base [68C] inside the Right Headlight Holder [68B], as shown in FIG.1, so that the two screw holes on both parts line up. Now, secure the Right Headlight Base to the Right Headlight Holder with two TYPE BP screws as indicated in FIG.2.

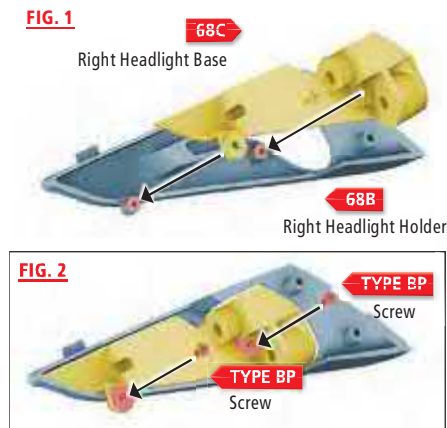

## STEP 04

### Attach the Right Headlight parts to the Front Body

Take the combined Right Headlight parts that you have just built and position the piece in the area of the Front Body [63A] indicated in the illustration. Make sure the two struts on the bottom of the Right Headlight Holder go into the two holes indicated in the Front Body.

FROM STEP 03  
Combined parts

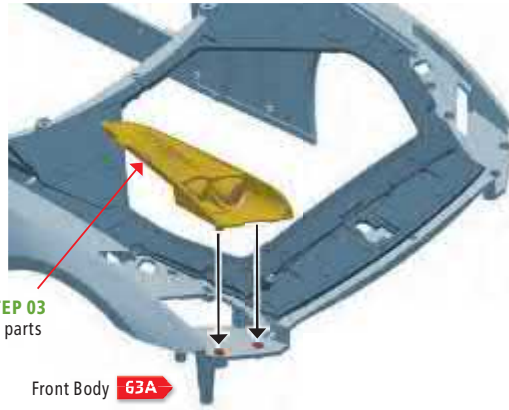

Front Body 63A

STEP 04 COMPLETE



## STEP 05

### Secure the Right Headlight parts to the Front Body

Holding the combined Right Headlight parts in place, turn the entire Car Body over and use two TYPE GP screws in the holes indicated in the illustration to secure the parts together.

Front Body 63A

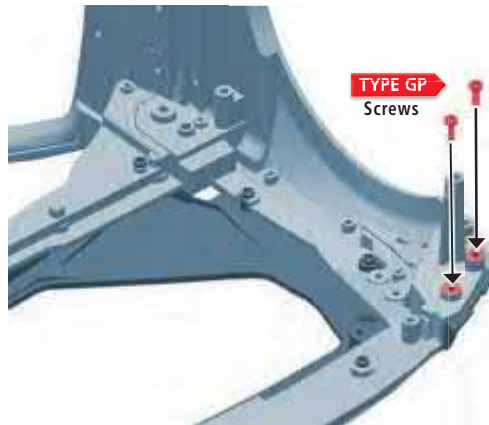

TYPE GP  
Screws

STEP 05 COMPLETE



## STEP 06

### Attach the Right Headlight Cover

Insert the Right Headlight Cover [68A] over the top of the combined Right Headlights parts, as shown in the illustration, so that the two struts on the bottom of the Right Headlight Cover go into the two holes in the Front Body.

Front Body 63A

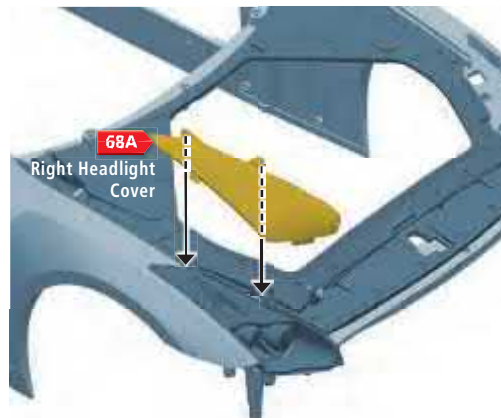

68A

Right Headlight  
Cover

STEP 06 COMPLETE



## STEP 07 Secure the Right Headlight Cover

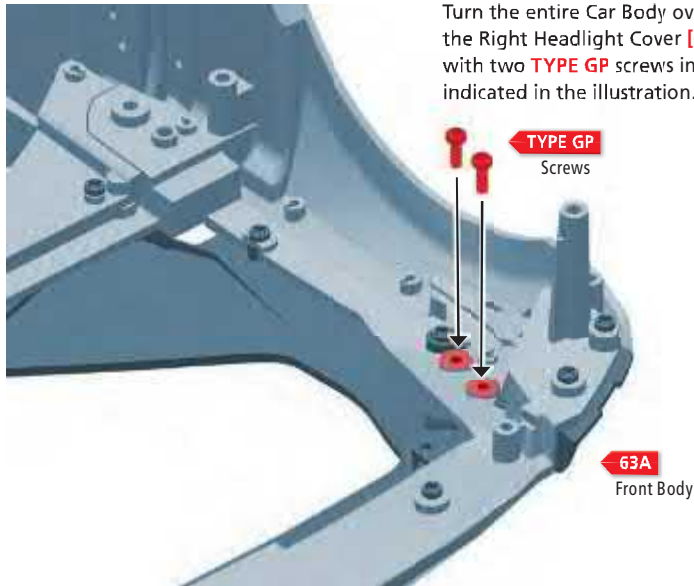

## Complete!

### The Right Headlight



This is how the Right Headlight should look once you have assembled these parts.

# THE LEFT HEADLIGHT

Next, you will assemble and attach the Left Headlight to your NISSAN GT-R (R35) model.

## PARTS LOCATION



## PARTS LIST

### PART IDENTIFICATION LIST

PART No.	NAME	QUANTITY	MATERIAL
69A	Left Headlight Cover	1	GP
69B	Left Headlight Holder	1	GP
69C	Left Headlight Base	1	ABS
69D	Headlight Lens	1	GP
69E	Sidelight Lens	1	GP
Screws	Type BP 0.06 x 0.12" [1.5 x 3mm]	2 [+2 spare]	Metal
Screws	Type GP 0.08 x 0.16" [2 x 4mm]	4 [+2 spare]	Metal
Screws	Type GM 0.08 x 0.16" [2 x 4mm]	2 [+2 spare]	Metal
Screws	Type DM 0.08 x 0.12" [2 x 3mm]	13 [+6 spare]	Metal



69A



69B



69C



69D



69E



TYPE BP



TYPE GP



TYPE GM



TYPE DM



## STEP 01 Attach the Headlight Lenses

Insert the Headlight Lens [69D] and the Sidelight Lens [69E] into the circular recesses of the Left Headlight Base [69C], as indicated in FIG.1. Ensure both Lenses are firmly in place by gently tapping them down with a straw or a pen, as shown in FIG.2.

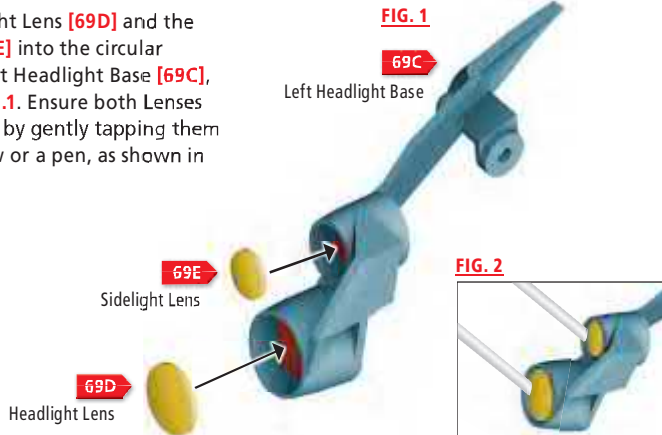

**COLOR KEY**  
■ PART BEING FITTED  
■ PART BEING FITTED TO  
■ FIXINGS



## STEP 02 Secure the Left Headlight Base to the Left Headlight Holder

Position the Left Headlight Base [69C] inside the Left Headlight Holder [69B], as shown in FIG.1, so that the two screw holes on both parts line up. Now, secure the Left Headlight Base to the Left Headlight Holder with two TYPE BP screws, as indicated in FIG.2.

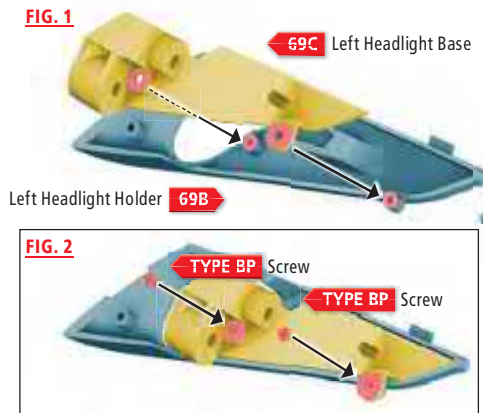

## STEP 03 Attach the Left Headlight parts to the Front Body

Take the combined Left Headlight parts that you have just built and position the piece in the area of the Front Body [63A] indicated in the illustration. Make sure the two struts on the bottom of the Left Headlight Holder go into the two holes indicated in the Front Body.

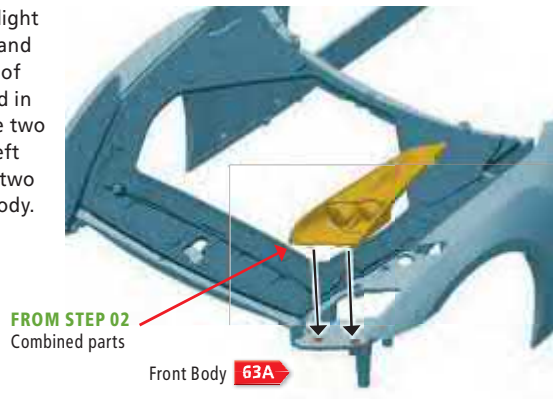

## STEP 04

### Secure the Left Headlight parts to the Front Body

Holding the combined Left Headlight parts in place, turn the entire Car Body over and use two **TYPE GP** screws in the holes indicated in the illustration to secure the parts together.

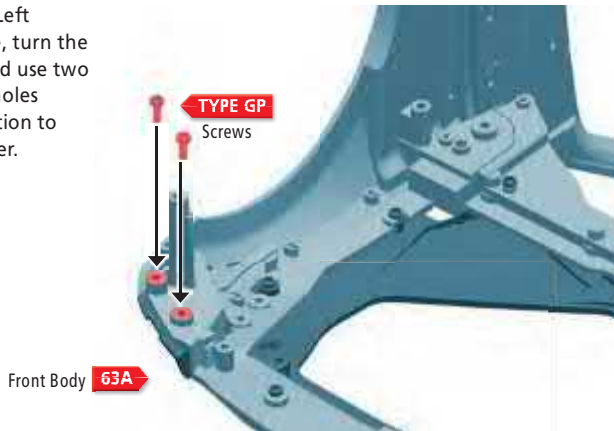

## STEP 05

### Attach the Left Headlight Cover

Insert the Left Headlight Cover **[69A]** over the top of the combined Left Headlights parts, as shown in the illustration, so that the two struts on the bottom of the Left Headlight Cover go into the two holes in the Front Body.

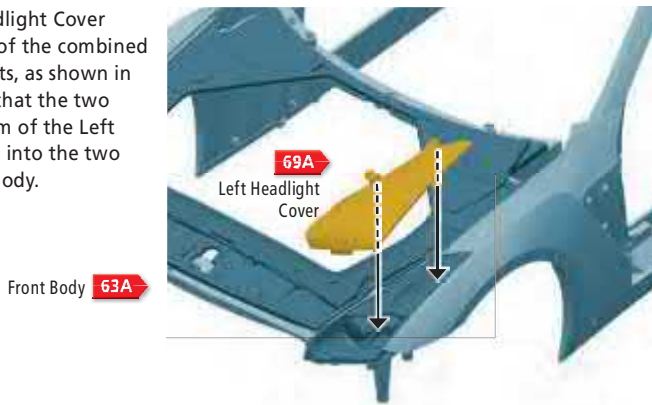

## STEP 06

### Secure the Left Headlight Cover

Turn the entire Car Body over and secure the Left Headlight Cover **[69A]** in place with two **TYPE GP** screws in the holes indicated in the illustration.

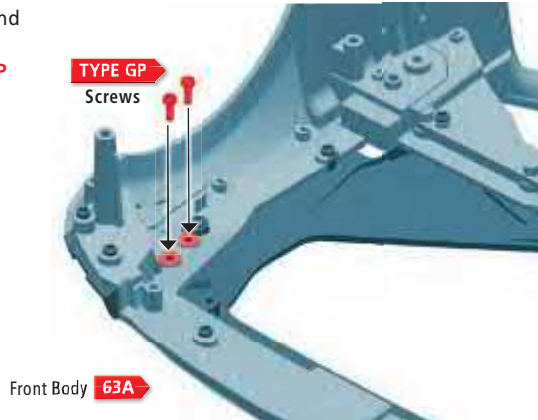

## Complete!

### Right and Left Headlights Complete

This is how the Right and Left Headlights should look on your NISSAN GT-R (R35) model when you have assembled these parts.



## STEP 07

### Attach the left side of the Interior Light Switch

Place one end of the Interior Light Switch [61B], which you received with Magazine 16, into the recess on the left side of the Rear Body [64A], as shown in FIG. 1 and FIG. 2.

Next, position the Interior Light Switch Clip [65B], which came with Magazine 17, over the top of the Interior Light Switch [61B], as shown in FIG. 3, and use a TYPE GM screw to hold the parts in place.

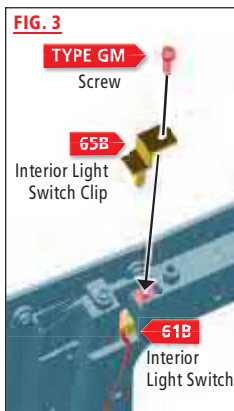
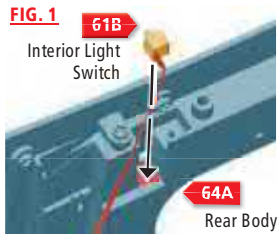

## STEP 08

### Attach the right side of the Interior Light Switch

Place the opposite end of the Interior Light Switch [61B] into the recess on the right side of the Rear Body [64A], as shown in FIG. 1 and FIG. 2.

Next, position the Interior Light Switch Clip [65C], which came with Magazine 17, over the top of the Interior Light Switch [61B], as shown in FIG. 3, and use a TYPE GM screw to hold the parts in place.

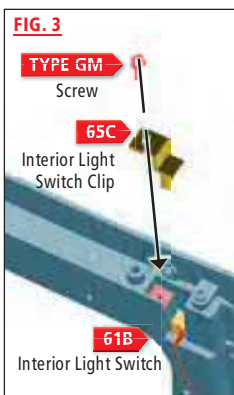
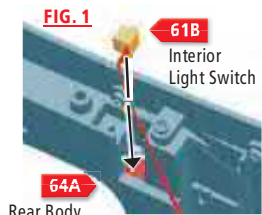

## STEP 09

### Attach the Interior Light Switch and Headlights wires to the Front Body

Lay out the Interior Light Switch [61B] wire (represented by the red wire) on the inside of the Front Body [63A], as shown in the illustration. Next, lay out the Headlights [61C] wire (represented by the blue wire) on the inside of the Front Body [63A]. Use the appropriate Wire Clips (that came with Magazine 17) to hold the wires neatly in place. All the Wire Clips should be attached with **TYPE DM** screws. The Front Body has 'D', '3', '4', '5' or '6' stamped next to the holes, to indicate which type of Wire Clip should be used in them.

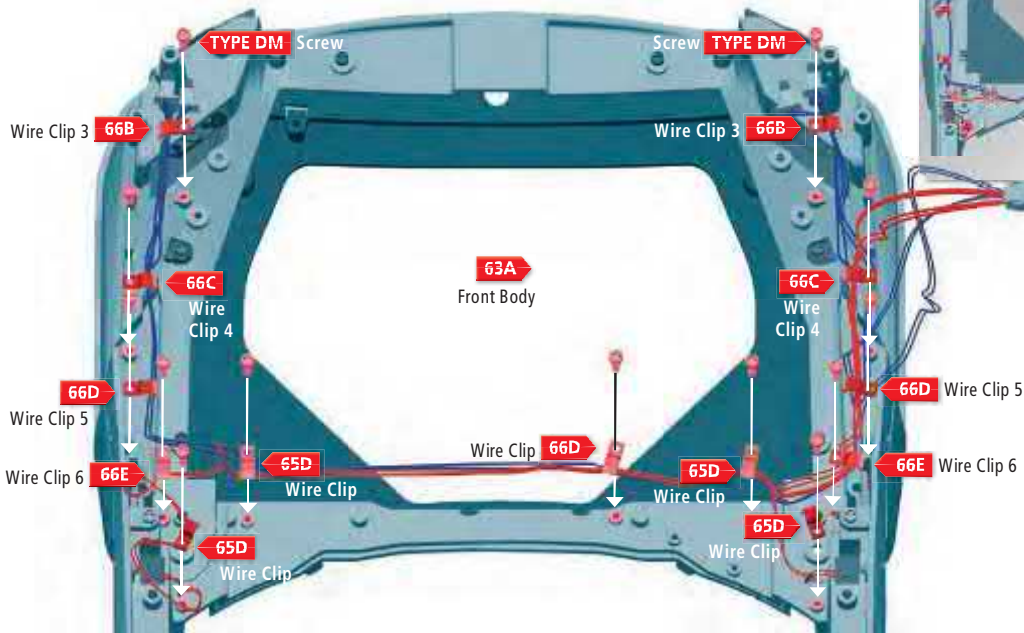
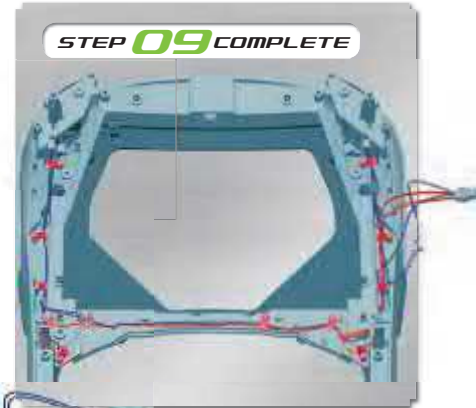

## STEP 10

### Secure the Right Headlight Bulbs

Push the Bulbs on the end of the Headlights [61C] wire into the two holes of the Right Headlight Base [68C], as indicated in the illustration. The Bulbs may appear to be too big for the holes, but they will go in if pushed firmly.

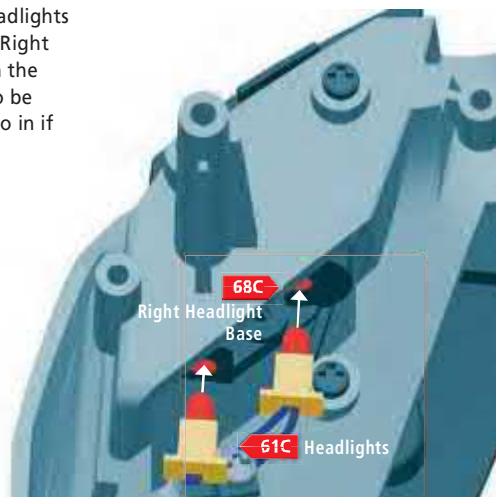

## STEP 11

### Secure the Left Headlight Bulb

Push the Bulbs on the opposite end of the Headlights [61C] wire into the two holes of the Left Headlight Base [69C], as indicated in the illustration. The Bulbs may appear to be too big for the holes, but they will go in if pushed firmly.

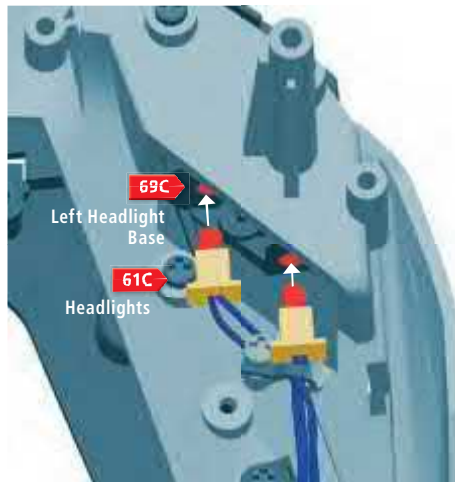

## Complete!

### The Front Body Wiring

This is how the Interior Light Switch and Headlights wiring should look on the Front Body of your model when you have completed these steps.



# THE WINDSHIELD

Now you will attach the Windshield to the body of your NISSAN GT-R (R35) model.

## PARTS LOCATION

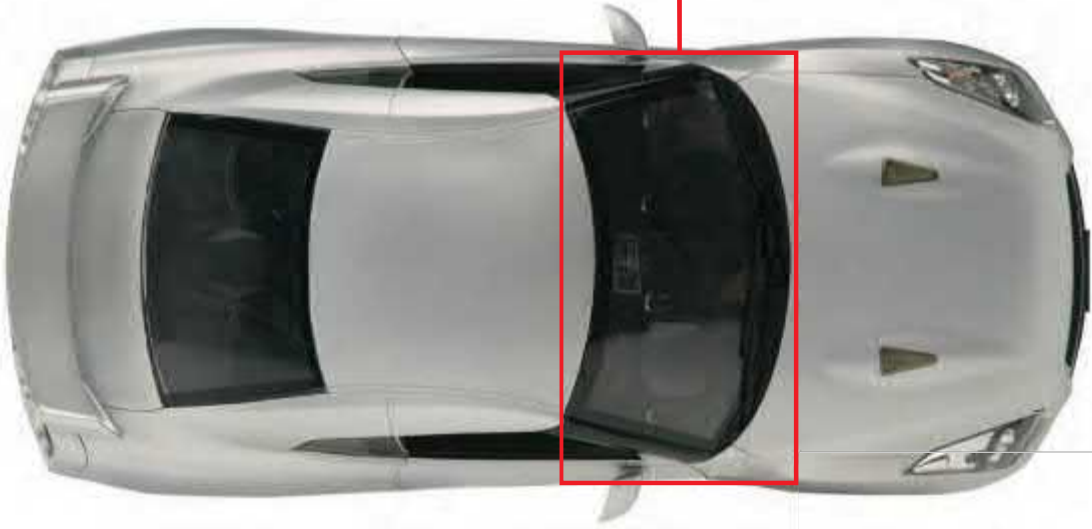

## PARTS LIST

### PART IDENTIFICATION LIST

PART No.	NAME	QUANTITY	MATERIAL
<b>70A</b>	Windshield	1	GP
<b>Screws</b>	Type QM 0.08 x 0.12" [2 x 3mm]	3 [+1 spare]	Metal
<b>Screws</b>	Type KP 0.08 x 0.3" [2 x 8mm]	1 [+1 spare]	Metal
<b>Screws</b>	Type GP 0.08 x 0.16" [2 x 4mm]	2 [+1 spare]	Metal



## STEP 01 Attach the Windshield

Position the Windshield [70A] so that the three struts at the top of it match up with the three holes on the inside of the car roof, while the three struts at the bottom of it match up with the three holes indicated by the black arrows in the illustration.



### COLOR KEY

- PART BEING FITTED
- PART BEING FITTED TO
- FIXINGS



## STEP 02 Secure the Windshield

Holding the Windshield [70A] in place, secure it to the Car Body with three **TYPE QM** screws in the holes in the roof; two **TYPE GP** screws on either side at the bottom; and one **TYPE KP** screw in the middle at the bottom, as shown.

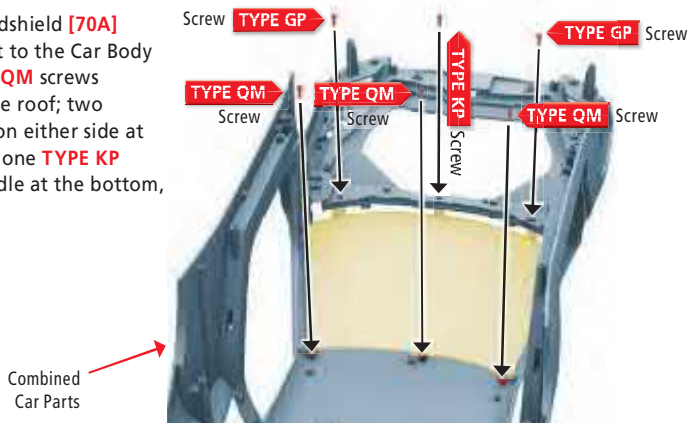

## Complete!

### The Windshield

This is how the exterior body of your model should look once you have attached the Windshield.







## THE WINDSHIELD WIPERS

In this magazine, you will assemble the Windshield Wipers and attach them to your NISSAN GT-R (R35) model.

### PARTS LOCATION

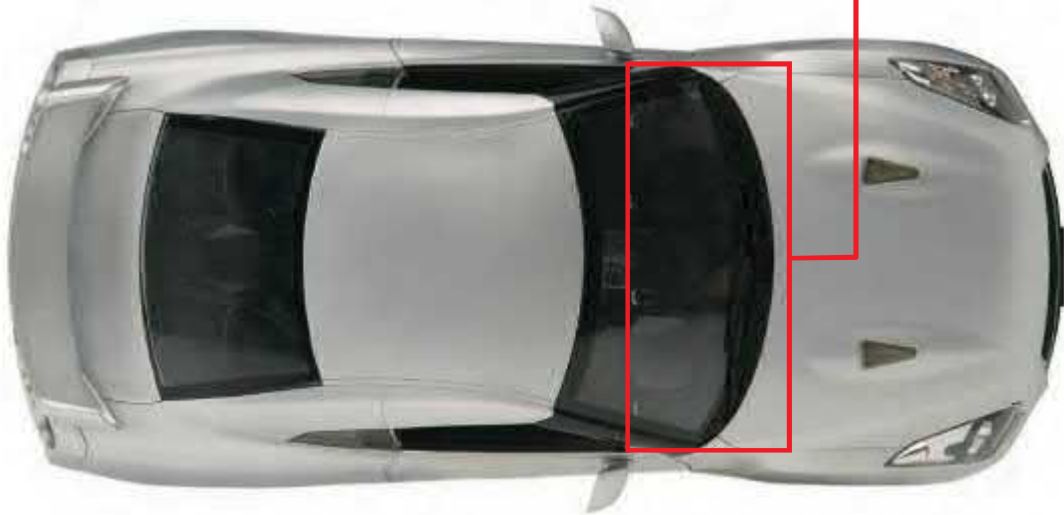

### PARTS LIST

### PART IDENTIFICATION LIST

PART No.	NAME	QUANTITY	MATERIAL
71A	Left Front Wiper	1	ABS
71B	Right Front Wiper	1	ABS
71C	Front Wiper Base	1	ABS
Screws	Type IP 0.6 x 0.12" [1.7 x 3mm]	2 [+2 spare]	Metal
Screws	Type GP 0.08 x 0.16" [2 x 4mm]	2 [+1 spare]	Metal



**TIP!**  
The Wipers have either an 'L' for left or an 'R' for right printed on the back, to help you tell them apart.



## STEP 01

### Attach the Front Wipers

Fit the Right Front Wiper [71B] and the Left Front Wiper [71A] into the holes on the upper side of the Front Wiper Base [71C], as shown in the illustration. Secure each Wiper in place from the other side with a TYPE IP screw.

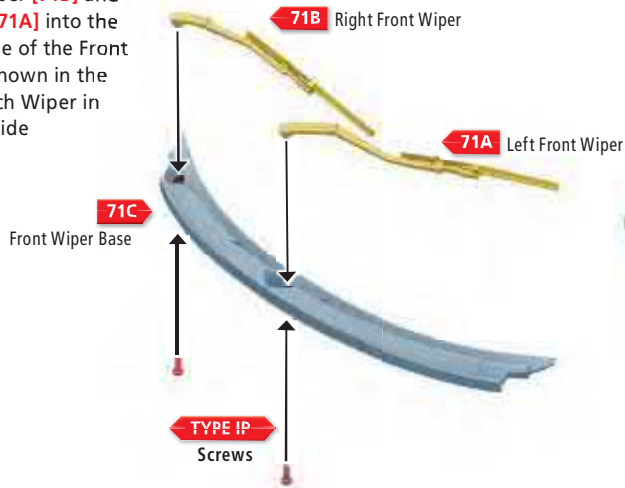

#### COLOR KEY

- PART BEING FITTED
- PART BEING FITTED TO
- FIXINGS

#### STEP 01 COMPLETE

## STEP 02

### Attach the combined Front Wipers to the Car Body

Insert the two struts on the bottom of the combined Front Wipers into the holes on the Front Body [63A], marked by the two black arrows in the illustration. Make sure the struts go fully down into the holes, so that the Wipers are resting against the Windshield.

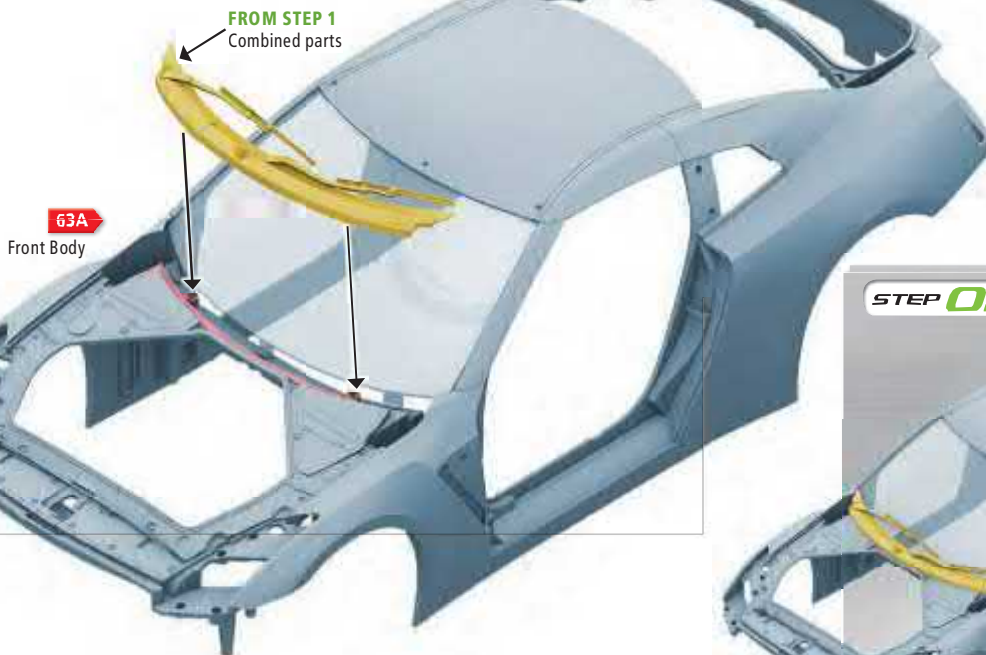

#### STEP 02 COMPLETE

## STEP 03 Secure the Front Wipers to the Car Body

Holding the combined Front Wipers firmly in place, turn the entire Car Body upside down and secure the combined Front Wipers in place with two **TYPE GP** screws in the holes indicated in the illustration.

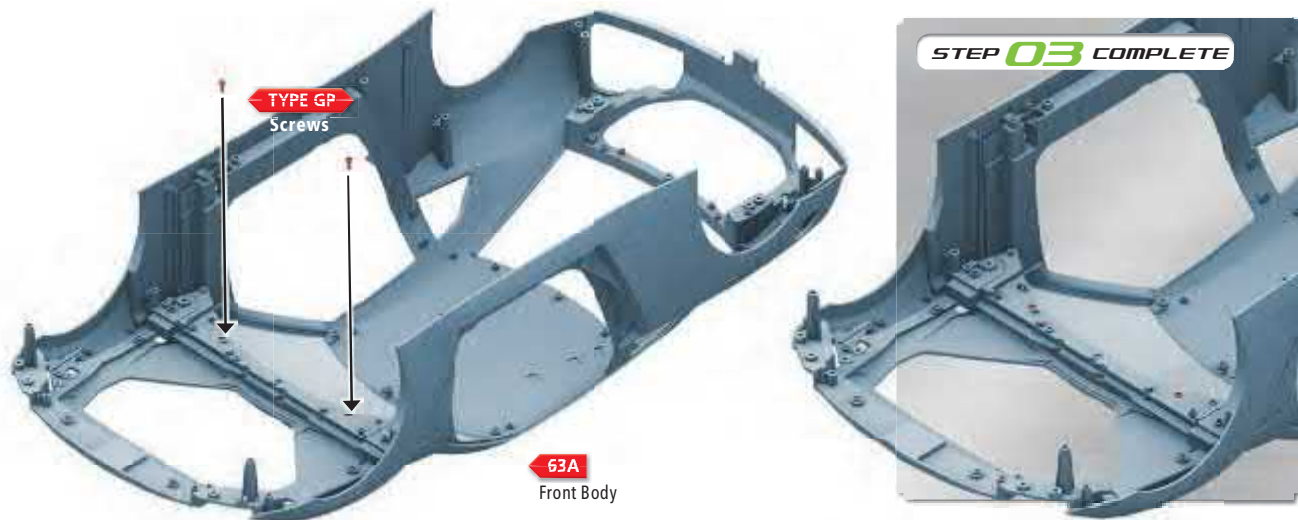

## Complete!

### The Windshield Wipers

This is how the Windshield Wipers should look on your model when you have added these parts.



# THE REAR WINDOW

Now you will attach the Rear Window to your NISSAN GT-R (R35) model.

## PARTS LOCATION



## PARTS LIST

### PART IDENTIFICATION LIST

PART No.	NAME	QUANTITY	MATERIAL
<b>72A</b>	Rear Window	1	GP
<b>Screws</b>	Type GM 0.08 x 0.16" [2 x 4mm]	3 [+1 spare]	Metal
<b>Screws</b>	Type GP 0.08 x 0.16" [2 x 4mm]	3 [+1 spare]	Metal



**T** TYPE GM

**T** TYPE GP

## STEP 01 Attach the Rear Window

Line up the Rear Window [72A] so that the three tabs at the top of it match up with the three holes on the underside of the car roof. The three tabs at the bottom of the Rear Window fit into the three holes on the rim of the trunk opening, indicated by the three black downward pointing arrows in the illustration.



**COLOR KEY**  
■ PART BEING FITTED  
■ PART BEING FITTED TO  
■ FIXINGS



## STEP 02 Secure the Rear Window

Holding the Rear Window [72A] in place, turn the entire Car Body upside down and secure it in place by using three **TYPE GM** screws in the holes in the roof and three **TYPE GP** screws in the holes next to the trunk space, as indicated in the illustration.

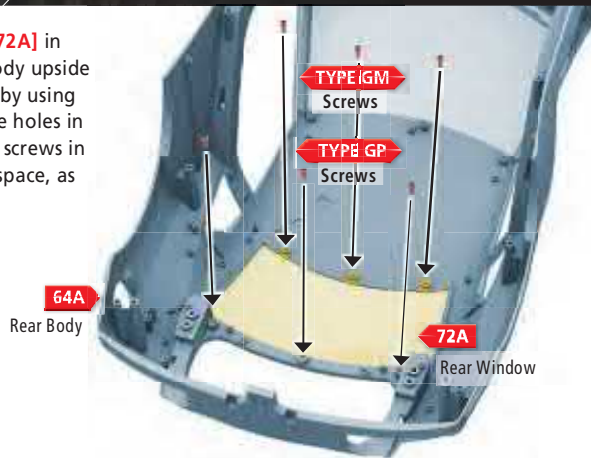

## Complete!

### The Rear Window

This is how the Rear Window should look on your NISSAN GT-R (R35) model once you have attached it.



# THE REAR QUARTER GLASS

Next, you will attach the Rear Quarter Glass to your model NISSAN GT-R (R35) model.

## PARTS LOCATION

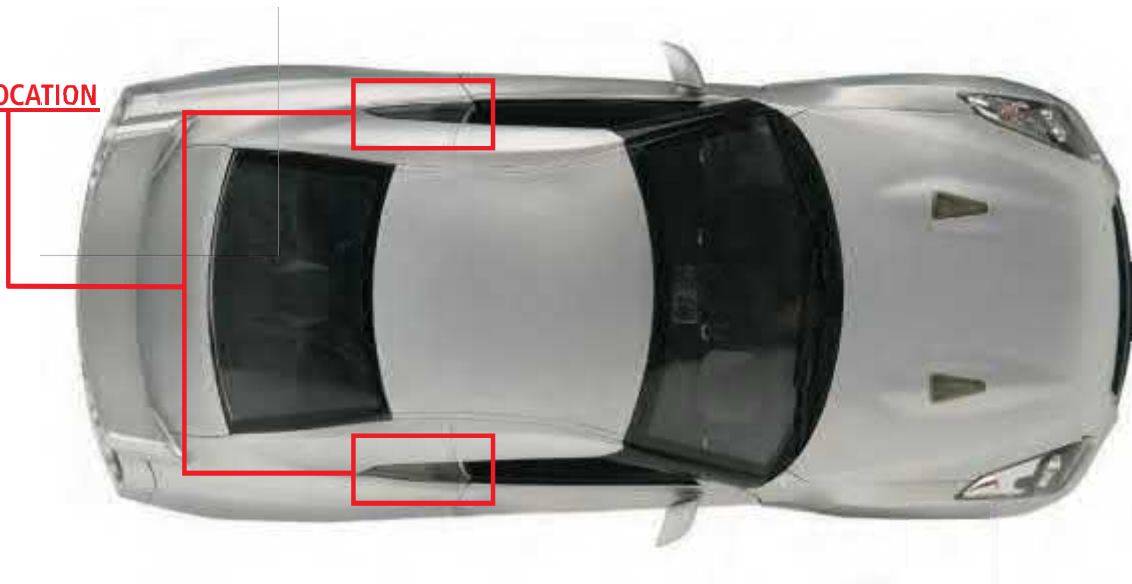

## PARTS LIST



### PART IDENTIFICATION LIST

PART No.	NAME	QUANTITY	MATERIAL
73A	Left Quarter Glass	1	GP
73B	Right Quarter Glass	1	GP
Screws	Type IP 0.06 x 0.12" [1.7 x 3mm]	4 [+2 spare]	Metal



73A

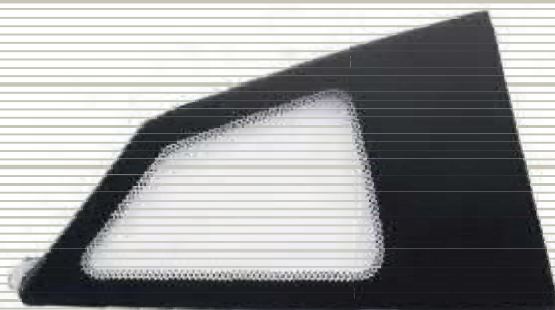

73B

## STEP 01 Attach the Left Quarter Glass

Insert the Left Quarter Glass [73A] into the area on the Rear Body [64A] shown in the illustration. Make sure that the two pegs on the back of the Left Quarter Glass go into the two holes indicated by the arrows in the illustration.

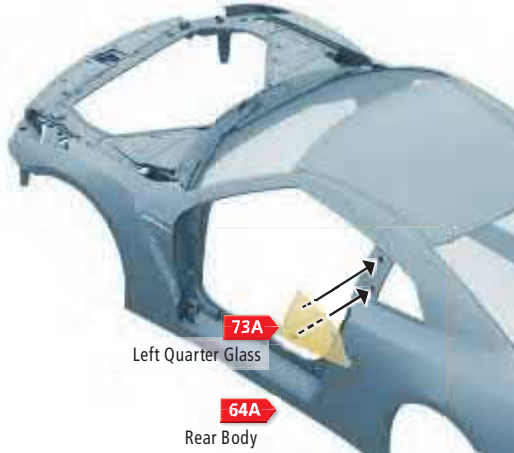

### COLOR KEY

- PART BEING FITTED
- PART BEING FITTED TO
- FIXINGS



## STEP 02 Secure the Left Quarter Glass to the Rear Body

Holding the Left Quarter Glass [73A] in place, use two TYPE IP screws in the holes on the inside of the Rear Body [64A], as indicated in the illustration, to secure it in place.

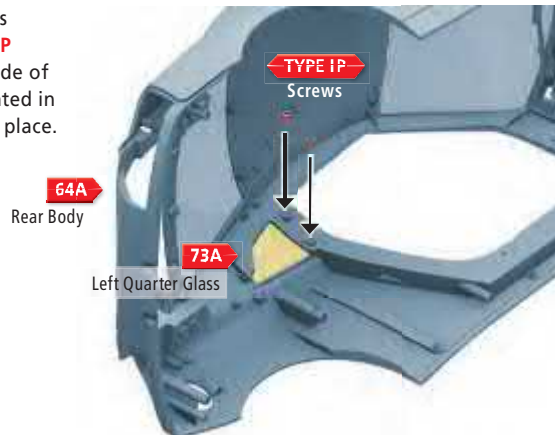

## STEP 03 Attach the Right Quarter Glass

Insert the Right Quarter Glass [73B] into the area on the Rear Body [64A], as shown in the illustration. Make sure that the two pegs on the back of the Right Quarter Glass go into the two holes indicated by the arrows in the illustration.

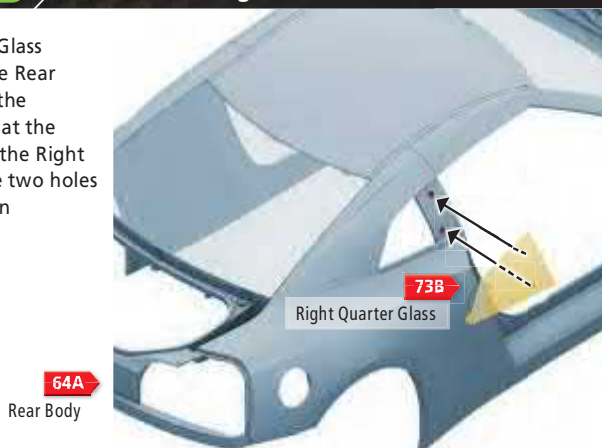

## STEP 04

### Secure the Right Quarter Glass to the Rear Body

Holding the Right Quarter Glass [73B] in place, use two **TYPE IP** screws in the holes on the inside of the Rear Body [64A], as indicated in the illustration, to secure it in place.

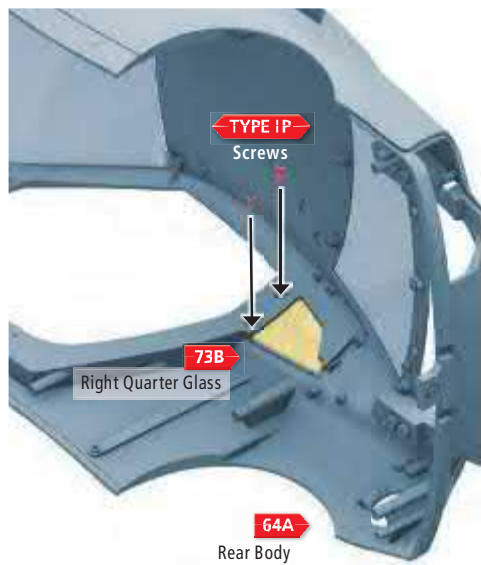

## Complete!

### The Rear Quarter Glass

This is how the Left and Right Rear Quarter Glass should look once you have fitted it to your model.





## THE REAR VIEW MIRROR

Now you will attach the Rear View Mirror to the roof of your NISSAN GT-R (R35) model.

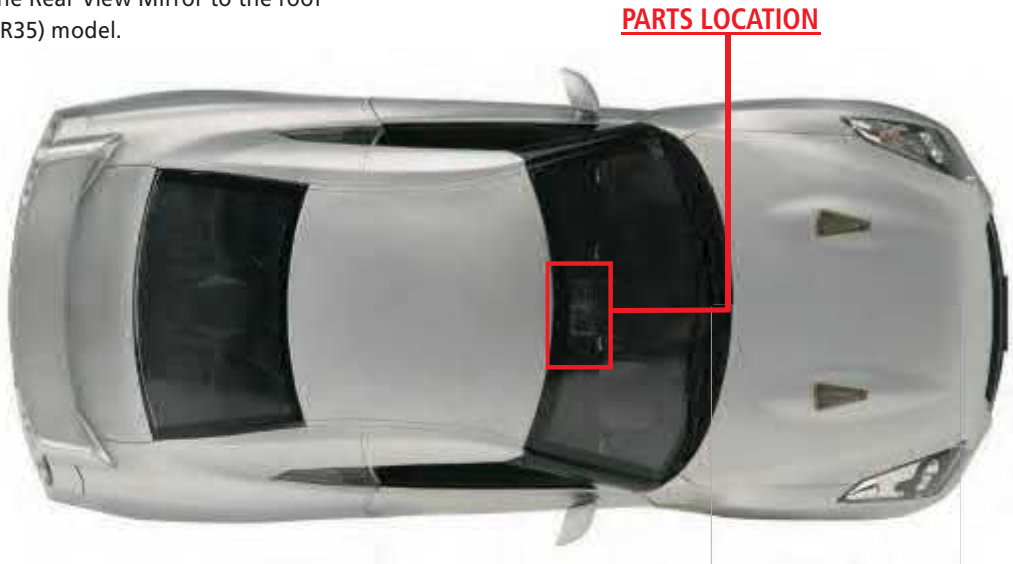

### PARTS LIST

#### PART IDENTIFICATION LIST

PART No.	NAME	QUANTITY	MATERIAL
74A	Rear View Mirror	1	ABS
74B	Rear View Mirror Surface	1	Photo Etch
74C	Roof Panel Light Cover	1	GP
Screws	Type BM 0.06 x 0.12" [1.5 x 3mm]	1 [+1 spare]	Metal



74A



TYPE BM



74B



74C



With this magazine, you also received a replacement part for [56C], the Steering Column Trim, and instructions on how to replace it. Please refer to the separate instruction sheet.

## STEP 01

### Attach the Rear View Mirror Surface

Unpeel the label on the back of the Rear View Mirror Surface [74B] to reveal its sticky side. Next, stick the Rear View Mirror Surface to the Rear View Mirror [74A], taking care that you put it on the correct way round.

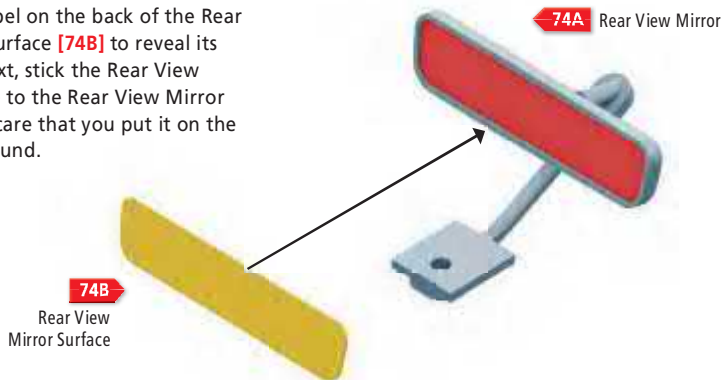

#### COLOR KEY

- PART BEING FITTED
- PART BEING FITTED TO
- FIXINGS

#### STEP 01 COMPLETE



## STEP 02

### Attach the Rear View Mirror to the inside of the Roof

Position the Rear View Mirror [74A] so that it lines up with the hole on the inside of the Roof of the Rear Body [64A], as shown in the illustration, and then secure it in place with a TYPE BM screw.

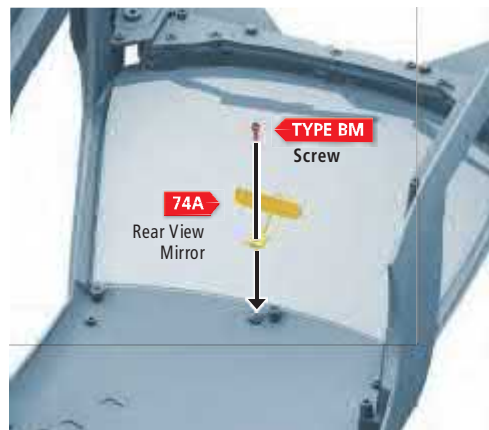

#### STEP 02 COMPLETE



## Complete!

### The Rear View Mirror

This is how the Rear View Mirror should look once it has been attached to your NISSAN GT-R (R35) model.

#### TIP!

Keep the Roof Panel Light Cover safe, as it will be attached to the car later.



## THE ROOF PANEL

In this magazine, you will fit the Interior Light and attach it to the Roof Panel of your NISSAN GT-R (R35).

### PARTS LOCATION

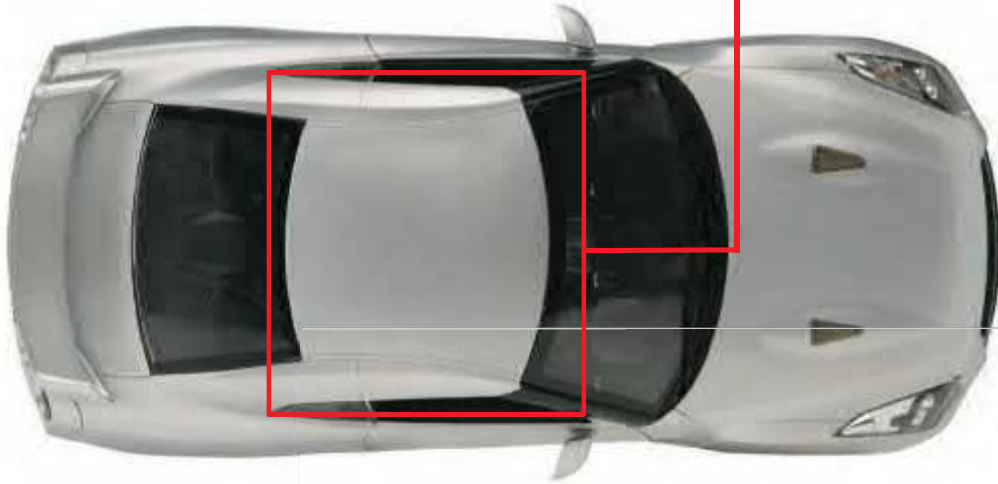

### PARTS LIST

#### PART IDENTIFICATION LIST

PART No.	NAME	QUANTITY	MATERIAL
75A	Roof Panel	1	ABS
75B	Wire Clip E	5	ABS
75C	Wire Clip F	1	ABS
75D	Wire Clip H	1	ABS
75E	Wire Clip J	2	ABS
Screws	Type IP 0.06 x 0.12"	2 [+1 spare]	Metal [1.7 x 3mm]
Screws	Type HM 0.09 x 0.16"	4 [+1 spare]	Metal [2.3 x 4mm]
Screws	Type DM 0.08 x 0.12"	13 [+2 spare]	Metal [2 x 3mm]

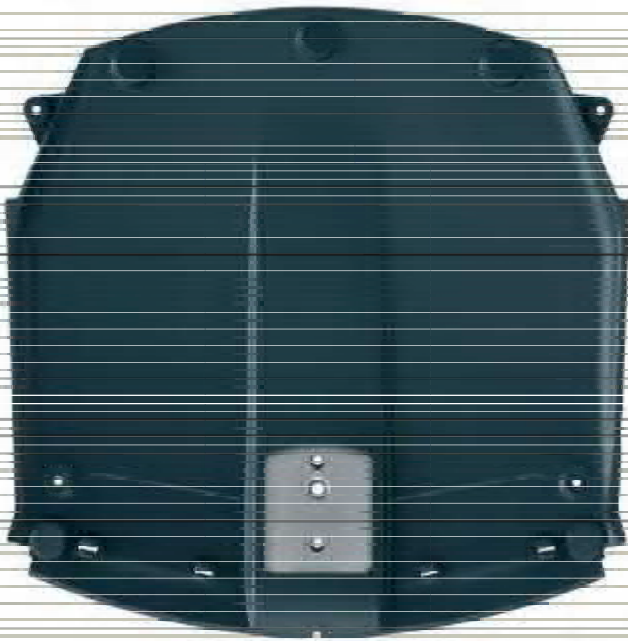

75A

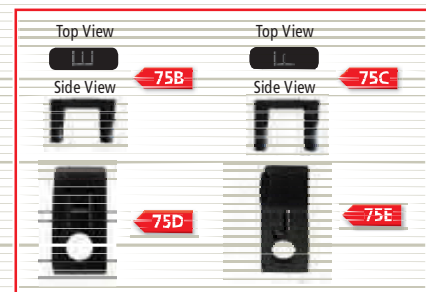

## STEP 01

### Attach the Roof Panel Light Cover

Push the Roof Panel Light Cover [74C] – which came with the previous magazine – into the holes in the Roof Panel [75A], as indicated in the illustration. Secure it in place from the opposite side with two **TYPE IP** screws.

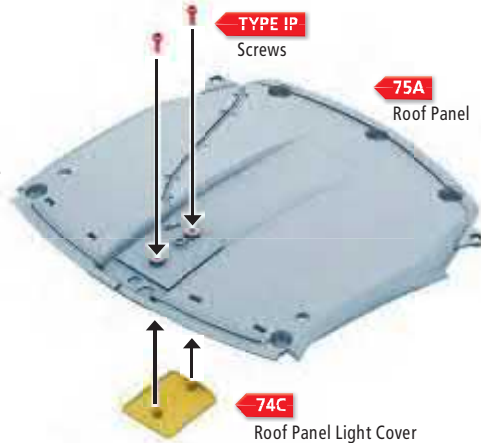

#### COLOR KEY

- PART BEING FITTED
- PART BEING FITTED TO
- FIXINGS

#### STEP 01 COMPLETE



## STEP 02

### Attach the Interior Light

Push the bulb on the end of the Interior Light [61D] into the hole in the Roof Panel [75A], as shown in **FIG. 1**. In the holes closest to the bulb, push in one Wire Clip F [75C], then push five Wire Clips E [75B] into the other holes to pin down the wire, as indicated in **FIG. 2**.

**FIG. 1**

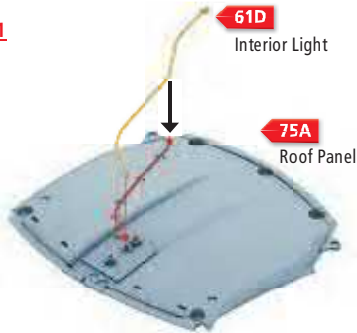

**FIG. 2**

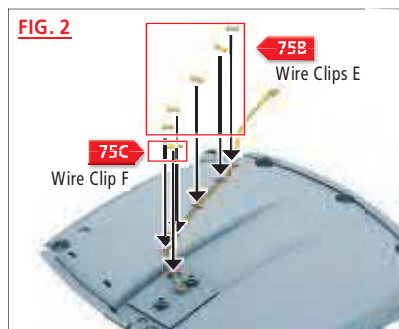

#### STEP 02 COMPLETE



## STEP 03

### Secure the Roof Panel to the Rear Body

Place the Roof Panel [75A] onto the inside of the Rear Body (Roof section) [64A], as shown in the illustration. Next, secure it in place with four **TYPE HM** screws in the holes indicated by the black arrows.

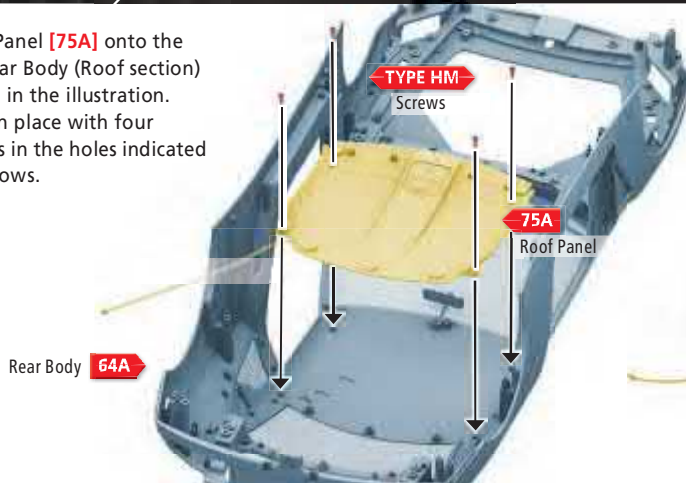

#### STEP 03 COMPLETE



## STEP 04 Secure the Interior Light wire



Secure the remainder of the Interior Light **[61D]** wire to the inside of the Rear Body **[64A]** with Wire Clips: use **TYPE DM** screws to attach one Wire Clip H **[75D]** and two Wire Clips J **[75E]** to hold the wire in place, as shown in the illustration.

## Complete!

### The Roof Panel

This is how the Roof Panel of your NISSAN GT-R (R35) should look when you have attached it to the car.



# THE SUN VISORS

Now you will assemble the Sun Visors and attach them to the Roof of your model.

## PARTS LOCATION

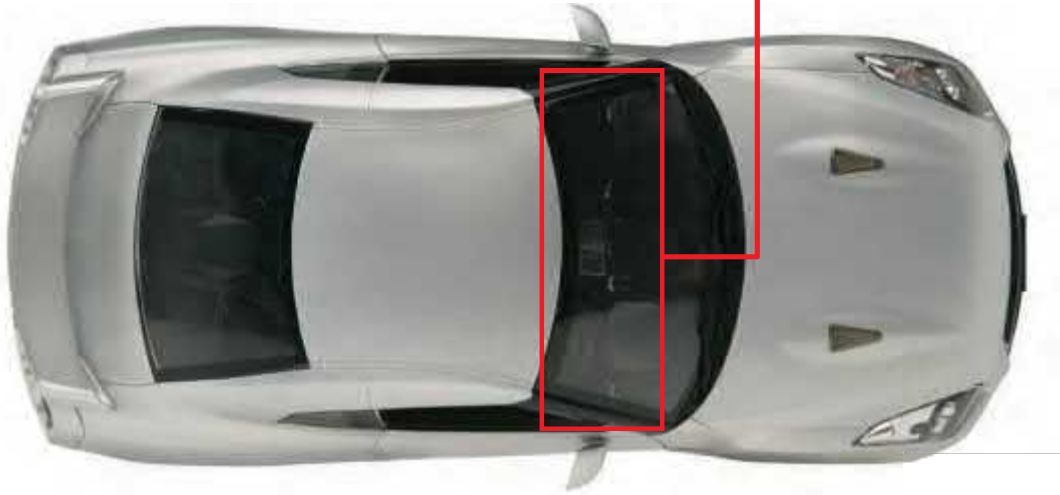

## PARTS LIST

### PART IDENTIFICATION LIST

PART No.	NAME	QUANTITY	MATERIAL
76A	Left Sun Visor	1	ABS
76B	Right Sun Visor	1	ABS
76C	Sun Visor Mirror	2	Label



76A



76C



76B

### TIP!

The Sun Visor Mirrors are identical, so it doesn't matter which Sun Visor you stick them on.

# HOW TO BUILD

## STEP 01 Attach a Mirror to the Right Sun Visor

Unpeel one of the Sun Visor Mirrors [76C] from its backing and position it – sticky side down – on the Right Sun Visor [76B], as indicated in the illustration.

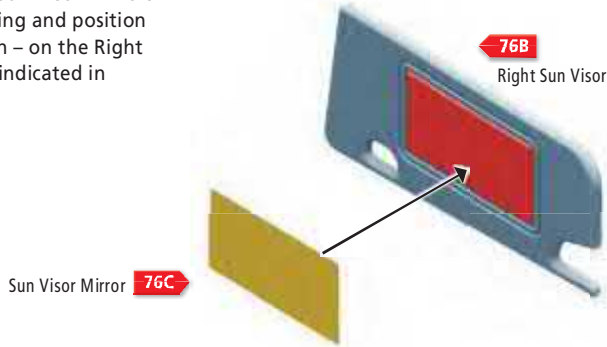

### COLOR KEY

- PART BEING FITTED
- PART BEING FITTED TO
- FIXINGS

### STEP 01 COMPLETE



## STEP 02 Attach a Mirror to the Left Sun Visor

Unpeel the second Sun Visor Mirror [76C] from its backing and position it – sticky side down – on the Left Sun Visor [76A], as indicated in the illustration.

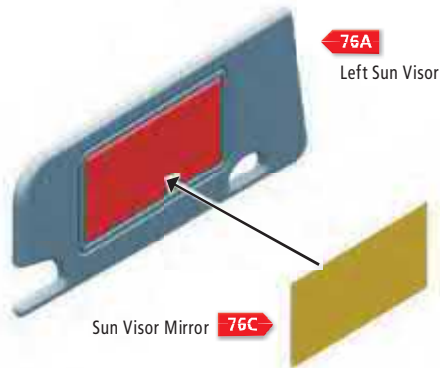

### STEP 02 COMPLETE



## STEP 03 Attach the Left Sun Visor to the Roof

Slide the peg on the end of the Left Sun Visor [76A] into the slot on the Roof of the Rear Body [64A], as shown in the illustration. Now, push the other side of the Visor into the second slot, as indicated by the black arrows.

### TIP!

It is very important that you **SLIDE** the peg of the Sun Visor into the slot, as it may break if you push it in.

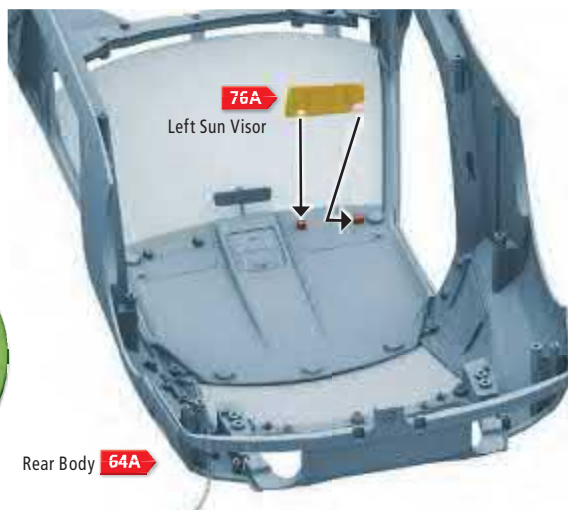

### STEP 03 COMPLETE



## STEP 04

### Attach the Right Sun Visor to the Roof

Slide the peg on the end of the Right Sun Visor [76B] into the slot on the Roof of the Rear Body [64A], as shown in the illustration. Now, push the other side of the Visor into the second slot, as indicated by the black arrows.

#### TIP!

Again, gently SLIDE the peg of the Sun Visor into the first slot, as it may break if you try to push it in.



## Complete!

### The Sun Visors

This is how the Sun Visors should look once you have attached them to the Roof of your NISSAN GT-R (R35) model.





## THE DOOR KICK PLATES

Next, you will attach the Left and Right Door Kick Plates to the Rear Body of your model.

### THE QUALITY IS IN THE DETAIL

The Door Kick Plates feature the GT-R logo, and are fitted to the bottom of the door sills as a stylish way of protecting them from scuffs and scratches.

### PARTS LOCATION



## PARTS LIST



Also with this magazine:  
**Door Opening Tool**

### PART IDENTIFICATION LIST

PART No.	NAME	QUANTITY	MATERIAL
77A	Left Door Kick Plate	1	ABS
77B	Right Door Kick Plate	1	ABS
Screws	Type MP 0.06 x 0.17" [1.7 x 4mm]	4 [+2 spare]	Metal

### TIP!

The Door Opening Tool features a magnet at one end and will be used to open the Fuel Filler Flap and the Doors.



77A



77B

## STEP 01

### Attach the Left Door Kick Plate

Position the Left Door Kick Plate [77A] at the bottom of the door opening on the left side of the Rear Body [64A], as indicated in the illustration.

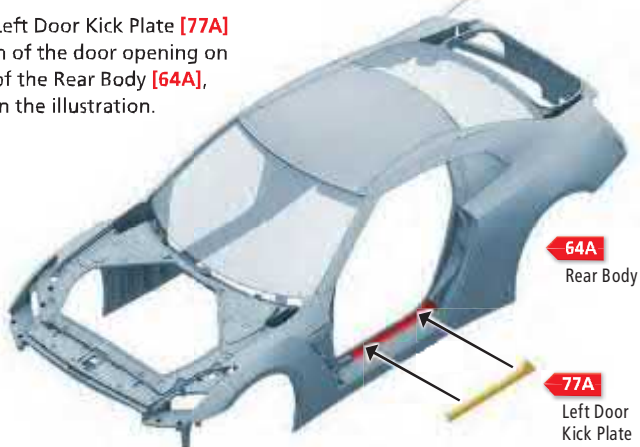

#### COLOR KEY

- PART BEING FITTED
- PART BEING FITTED TO
- FIXINGS



## STEP 02

### Secure the Left Door Kick Plate

Holding the Left Door Kick Plate [77A] firmly in place, secure it in position from the inside of the Rear Body [64A] with two TYPE MP screws in the holes indicated in the illustration.

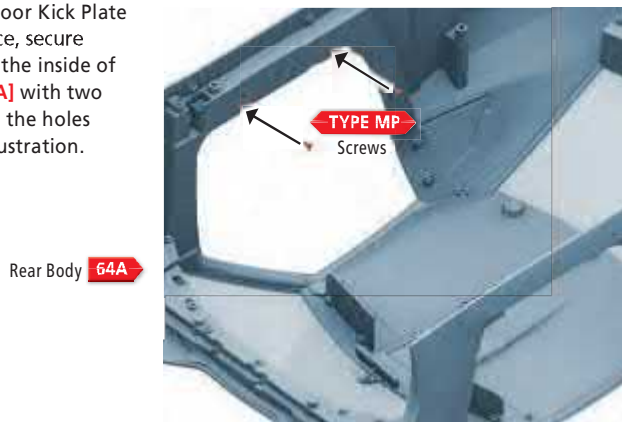

## STEP 03

### Attach the Right Door Kick Plate

Position the Right Door Kick Plate [77B] at the bottom of the door opening on the right side of the Rear Body [64A] as indicated in the illustration.

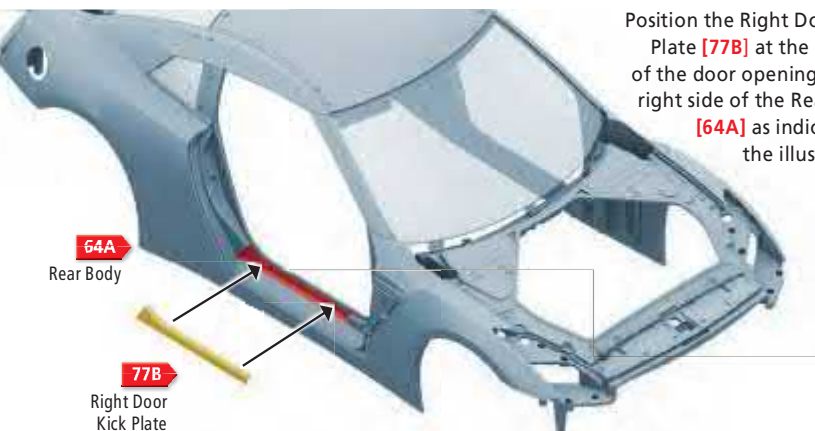

## STEP 04 Secure the Right Door Kick Plate

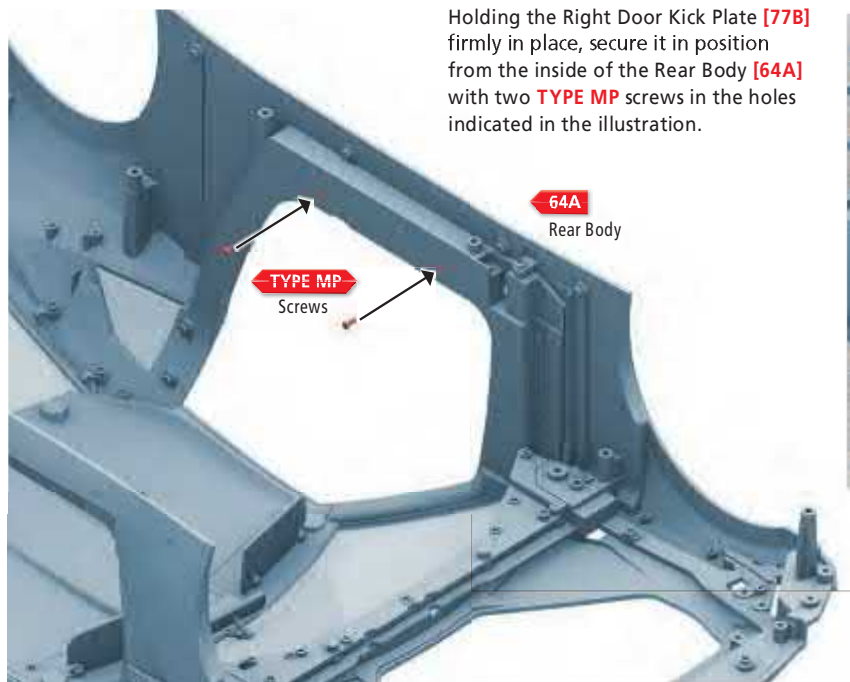

## Complete!

### The Door Kick Plates

This is how the Left Door Kick Plate should look once you have attached it to your NISSAN GT-R (R35) model. The Right Door Kick Plate should look the same on the other side of the car.



# THE FUEL FILLER ASSEMBLY

Now you will attach the Fuel Filler Assembly to the Rear Body of your model.

## PARTS LOCATION



## PARTS LIST

### PART IDENTIFICATION LIST

PART No.	NAME	QUANTITY	MATERIAL
78A	Fuel Filler Flap	1	Zinc
78B	Fuel Filler Neck	1	ABS
78C	Fuel Filler Holder	1	ABS
78D	Lubricating Oil	1	Oil
Screws	Type HM 0.09 x 0.16" [2.3 x 4mm]	2 [+1 spare]	Metal
Screws	Type AM 0.1 x 0.16" [2.6 x 4mm]	1 [+1 spare]	Metal

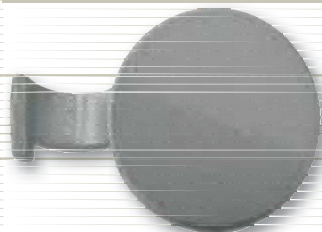

78A



78B

**TIP!**  
You will also have received a sachet of Lubricating Oil [78D] for the hinges of the Fuel Filler Flap and Neck.



78C



TYPE HM



TYPE AM

## STEP 01 Position the Fuel Filler Flap

First, smear a little of the Lubricating Oil onto the hinge of the Fuel Filler Flap [78A]. Next, position the Fuel Filler Flap in the opening of the Rear Body [64A], as shown in the illustration, and hold it there.

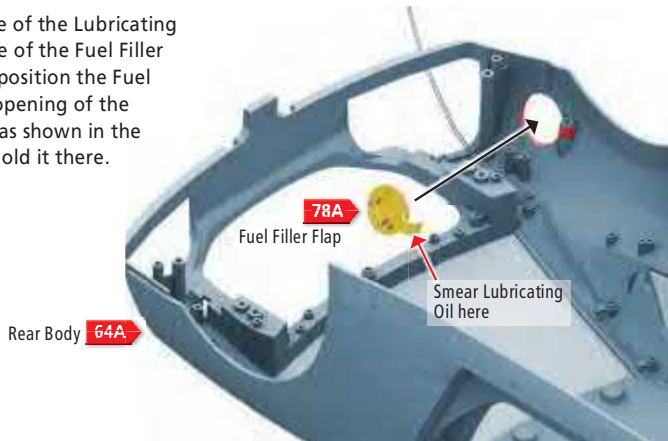

### COLOR KEY

- PART BEING FITTED
- PART BEING FITTED TO
- FIXINGS



## STEP 02 Attach the Fuel Filler Neck

FIG. 1

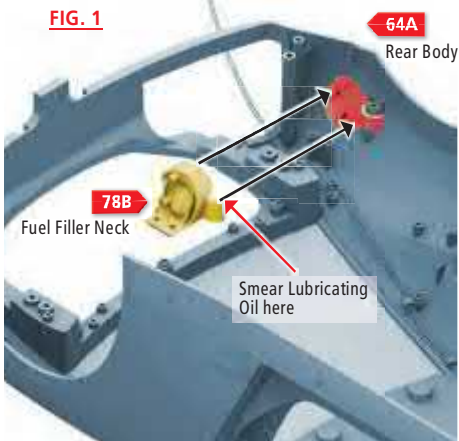

Add a little more of the Oil to the front side of the hinge on the Fuel Filler Neck [78B]. Next, place the Fuel Filler Neck on the inside of the Rear Body [64A], as shown in FIG. 1. Then secure it in place with two TYPE HM screws, as indicated in FIG. 2.

FIG. 2

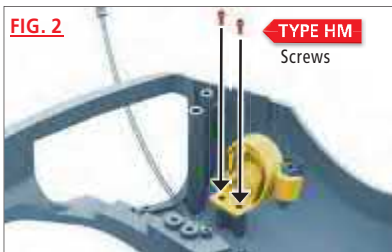

## STEP 03 Attach the Fuel Filler Holder

FIG. 1



Position the Fuel Filler Holder [78C] on the inside of the Rear Body [64A], as indicated in FIG. 1. Next, secure the Fuel Filler Holder in place with a TYPE AM screw, as shown in FIG. 2.

FIG. 2



## STEP 04

### Opening the Fuel Filler Flap with the Door Opening Tool

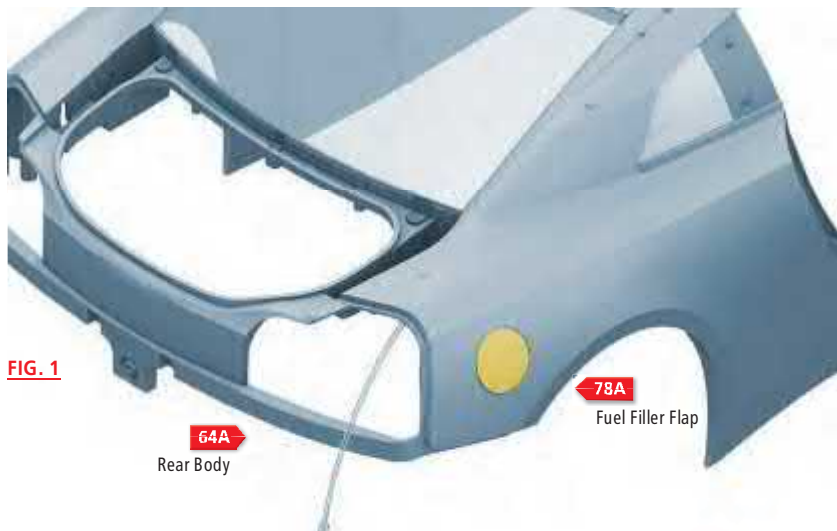

In order to avoid scratching your model's paintwork when opening the Fuel Filler Flap [78A], you should use the Door Opening Tool that came with magazine 20. Just place it on the Fuel Filler Flap as shown in FIG. 2 to open it slightly, then gently use your fingers to open it fully.

## Complete!

### The Fuel Filler Assembly

This is how the Fuel Filler Flap should look (in the closed position) once you have attached it to your NISSAN GT-R (R35) model.

#### TIP!

The Door Opening Tool that came with this magazine should always be used to open the Fuel Filler Flap.



# HOW TO BUILD

## THE HOOD

In this magazine, you will attach the Left and Right Hood Vents to the Hood of your NISSAN GT-R (R35) model.

### PARTS LOCATION

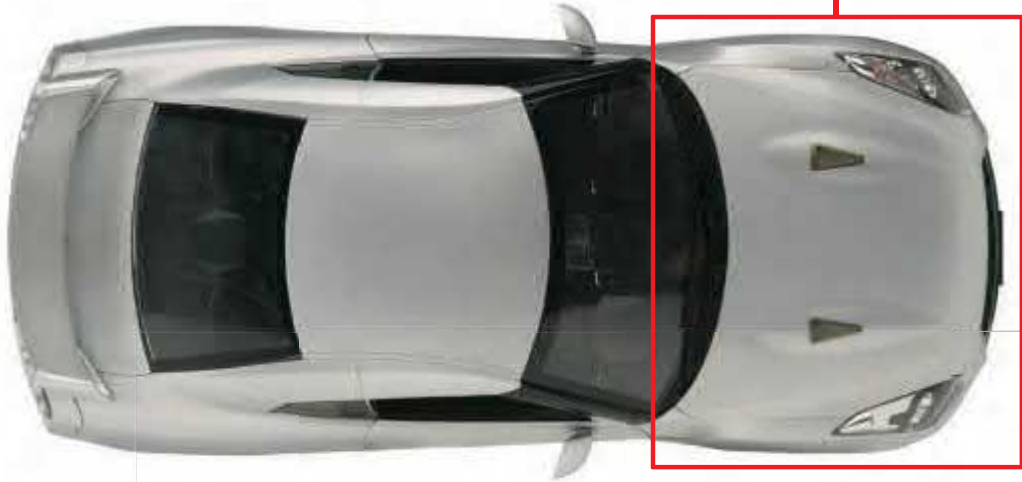

### PARTS LIST

#### PART IDENTIFICATION LIST

PART No.	NAME	QUANTITY	MATERIAL
79A	Hood	1	Zinc
79B	Left Hood Vent	1	ABS
79C	Right Hood Vent	1	ABS



#### TIP!

The Hood Vents have either 'L' for Left or 'R' for Right printed on the back to help you tell them apart.

## STEP 01

### Attach the Left Hood Vent to the Hood

Push the Left Hood Vent [79B] firmly into the space on the reverse side of the Hood [79A], as shown in the illustration. This part just pushes into place and no screws are required.



#### COLOR KEY

- PART BEING FITTED
- PART BEING FITTED TO
- FIXINGS



## STEP 02

### Attach the Right Hood Vent to the Hood

Push the Right Hood Vent [79C] firmly into the space on the reverse side of the Hood [79A], as shown in the illustration. This part just pushes into place and no screws are needed.



## Complete!

### The Hood

This is how the Hood should look once you have attached the Left and Right Hood Vents.





## THE HOOD INNER PANEL

Now you will attach the Hood Inner Panel and Catches to the Hood of your car.

### PARTS LOCATION

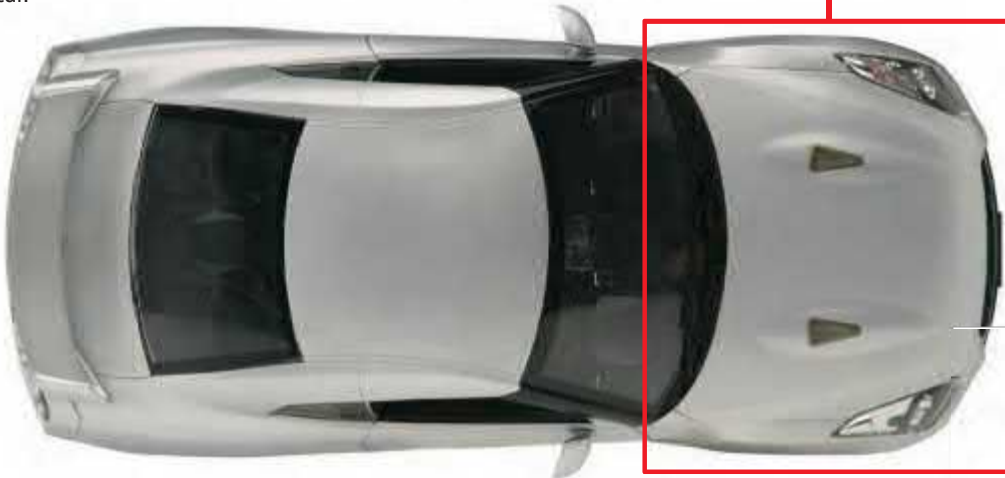

### PARTS LIST

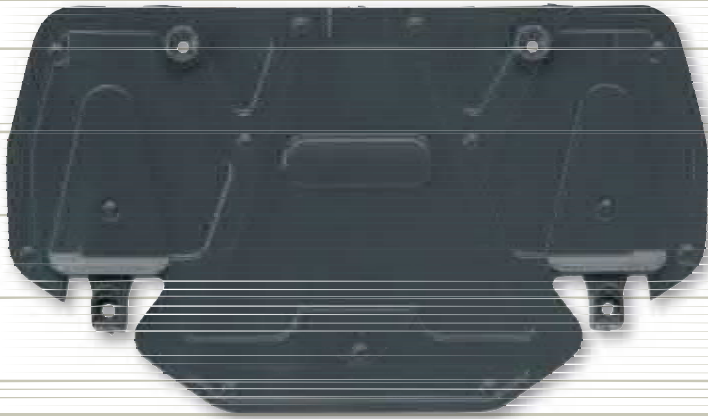

80A

### PART IDENTIFICATION LIST

PART No.	NAME	QUANTITY	MATERIAL
80A	Hood Inner Panel	1	ABS
80B	Left Hood Catch	1	ABS
80C	Center Hood Catch	1	ABS
80D	Magnet	1	Fe
80E	Right Hood Catch	1	ABS
Screws	Type IM 0.07 x 0.12" [1.7 x 3mm]	2 [+2 spare]	Metal
Screws	Type GM 0.08 x 0.16" [2 x 4mm]	5 [+2 spare]	Metal



TYPE IM



TYPE GM



80B



80C



80D



80E

### TIP!

The Left and Right Hood Catches have either 'R' or 'L' printed on the back to help you tell them apart.

## STEP 01

### Attach the Hood Inner Panel

Line up the four holes on the Hood Inner Panel [80A] with the four struts on the reverse side of the Hood [79A], as shown in FIG. 1.

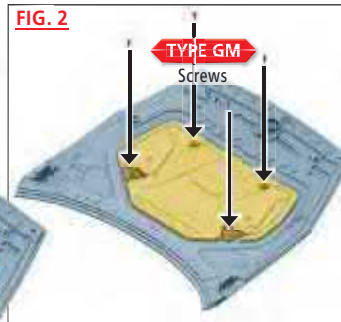
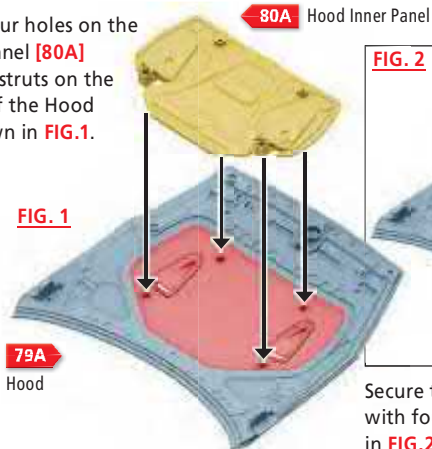

Secure the Hood Inner Panel [79A] with four TYPE GM screws, as shown in FIG. 2.

#### COLOR KEY

- PART BEING FITTED
- PART BEING FITTED TO
- FIXINGS



## STEP 02

### Attach the Left Hood Catch

FIG. 1



Position the Left Hood Catch [80B] in the area indicated in FIG. 1 and secure it in place with a TYPE IM screw from above, as shown in FIG. 2.

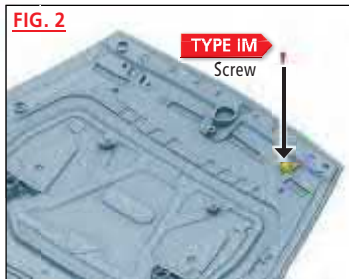

## STEP 03

### Attach the Right Hood Catch

FIG. 1



Position the Right Hood Catch [80E] in the area indicated in FIG. 1 and secure it in place with a TYPE IM screw from above, as shown in FIG. 2.

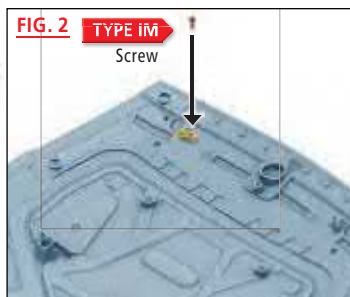

## STEP 04 Attach the Magnet and Center Hood Catch

FIG. 1

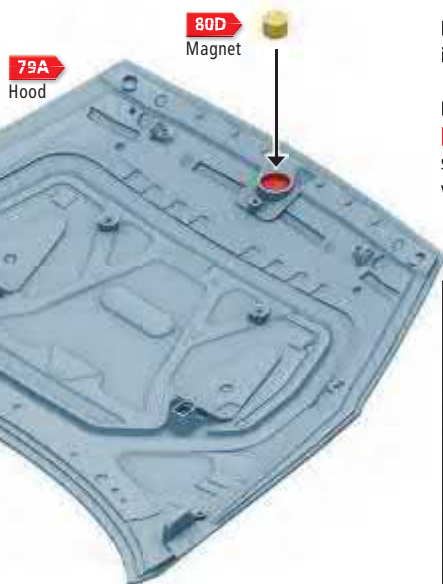

Place the Magnet [80D] in the hole indicated on the Hood [79A] in FIG.1,

Now, place the Center Hood Catch [80C] over the top of the Magnet, as shown in FIG.2, and secure it in place with a TYPE GM screw.

FIG. 2

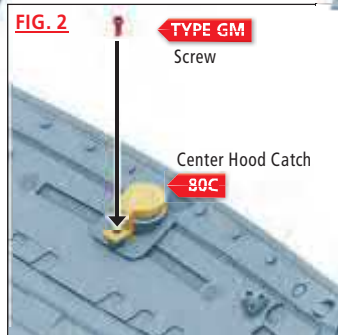

STEP 04 COMPLETE



### Complete!

#### The Inner Hood Panel

This is how the reverse side of the Hood should look once you have attached these parts.



# THE LEFT HOOD HINGE

Next, you will assemble the Left Hood Hinge and attach it to the Hood of your model.

## PARTS LOCATION

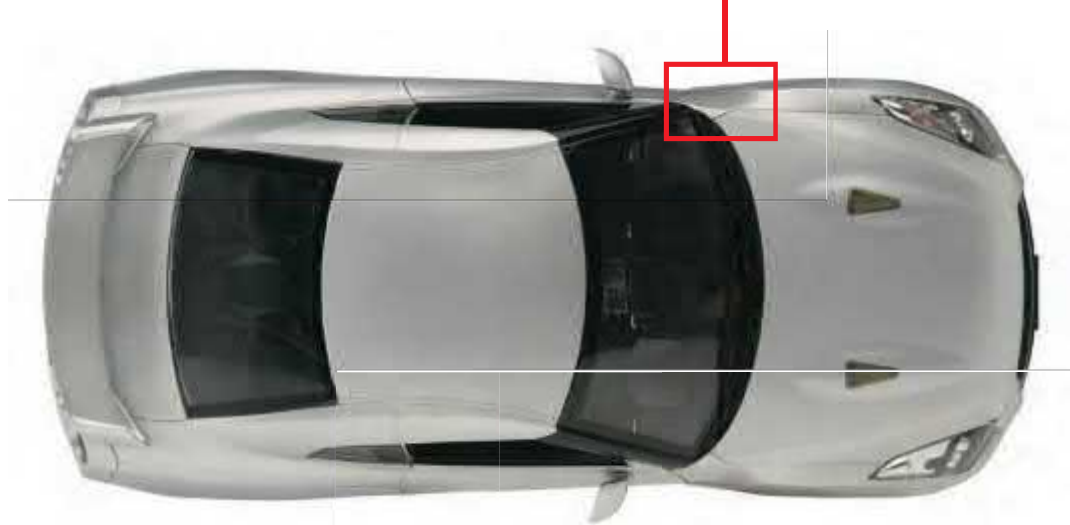

## PARTS LIST

### PART IDENTIFICATION LIST

PART No.	NAME	QUANTITY	MATERIAL
81A	Left Hood Hinge Base	1	Zinc
81B	Left Hood Hinge Cover	1	ABS
81C	Left Hood Hinge	1	ABS
Screws	Type IM 0.07 x 0.12" [1.7 x 3mm]	3 [+2 spare]	Metal
Screws	Type MM 0.07 x 0.16" [1.7 x 4mm]	2 [+1 spare]	Metal

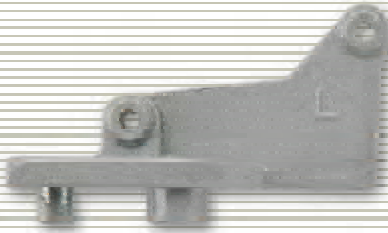

81A



81B



81C



TYPE IM



TYPE MM

## STEP 01

### Attach the Left Hood Hinge to the Left Hood Hinge Base

Line up the holes of the Left Hood Hinge [81C] with the holes of the Left Hood Hinge Base [81A], as shown in FIG.1.

Secure the parts together with two TYPE IM screws from above, as shown in FIG.2.

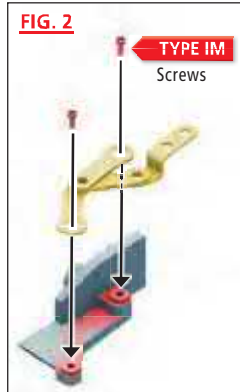
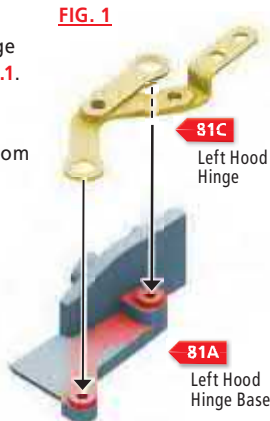

#### COLOR KEY

- PART BEING FITTED
- PART BEING FITTED TO
- FIXINGS



## STEP 02

### Attach the combined Left Hood Hinge to the Hood

Line up the holes of the Left Hood Hinge [81C] with the two holes on the raised area of the Hood [79A] shown in FIG.1. Secure the parts together with two TYPE MM screws from the side, as shown in FIG.2.

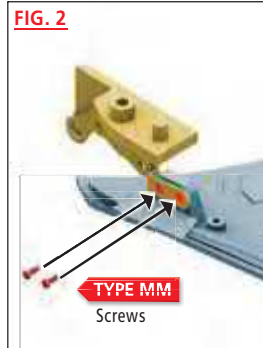

## STEP 03

### Attach the Left Hood Hinge Cover

Place the Left Hood Hinge Cover [81B] over the top of the Left Hood Hinge [81C], as shown in the illustration, making sure that the peg on the bottom of the Left Hood Hinge Cover goes into the hole in the Hood [79A].



## STEP 04

### Secure the Left Hood Hinge Cover to the Hood

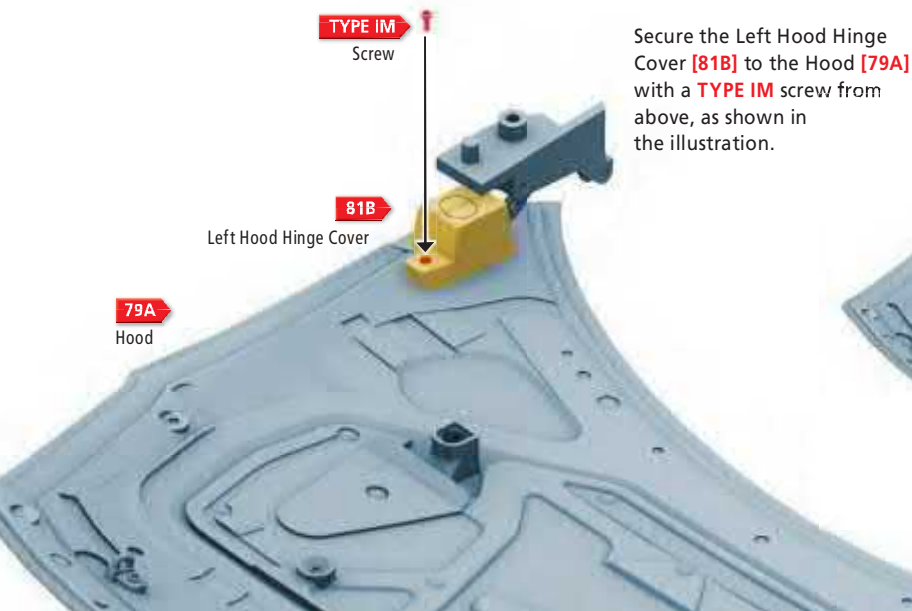

Secure the Left Hood Hinge Cover [81B] to the Hood [79A] with a TYPE IM screw from above, as shown in the illustration.



## Complete!

### The Left Hood Hinge

This is how the Left Hood Hinge should look once you have attached it to your NISSAN GT-R (R35) model.



## THE RIGHT HOOD HINGE

Now you will assemble the Right Hood Hinge and attach it to the Hood of your model.



PARTS LOCATION

### PARTS LIST



82A



82B



82C



TYPE IM



TYPE MM



TYPE AM

### PART IDENTIFICATION LIST

PART No.	NAME	QUANTITY	MATERIAL
82A	Right Hood Hinge Base	1	Zinc
82B	Right Hood Hinge Cover	1	ABS
82C	Right Hood Hinge	1	Fe
Screws	Type IM 0.07 x 0.12" [1.7 x 3mm]	3 [+2 spare]	Metal
Screws	Type MM 0.07 x 0.16" [1.7 x 4mm]	4 [+3 spare]	Metal
Screws	Type AM 0.1 x 0.16" [2.6 x 4mm]	2 [+2 spare]	Metal

## STEP 01

### Attach the Right Hood Hinge to the Right Hood Hinge Base

#### COLOR KEY

- PART BEING FITTED
- PART BEING FITTED TO
- FIXINGS

Line up the holes of the Right Hood Hinge [82C] with the holes of the Right Hood Hinge Base [82A], as shown in FIG.1.

FIG. 1

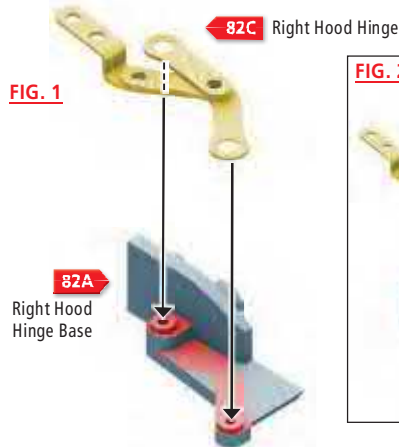
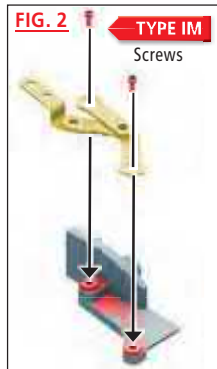

FIG. 2



Secure the parts together with two TYPE IM screws from above, as shown in FIG.2.

## STEP 02

### Attach the combined Right Hood Hinge to the Hood

Line up the holes of the Right Hood Hinge [82C] with the two holes on the raised area of the Hood [79A] shown in FIG.1. Secure the parts together with two TYPE MM screws from the side, as shown in FIG.2.

FIG. 1

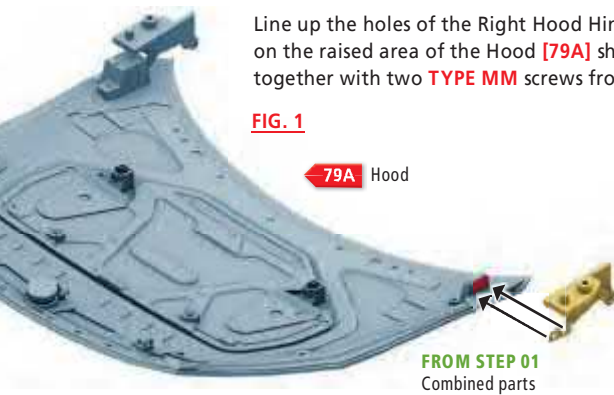
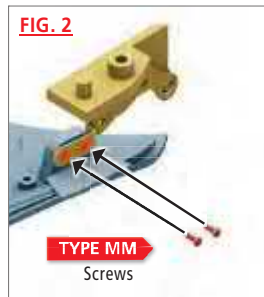

FIG. 2



## STEP 03

### Attach the Right Hood Hinge Cover

FIG. 1

Right Hood Hinge Cover [82B]

82C Right Hood Hinge

79A Hood

Place the Right Hood Hinge Cover [82B] over the top of the Right Hood Hinge [82C], as shown in FIG.1, before securing it in place with a TYPE IM screw from above, as shown in FIG.2.

FIG. 2

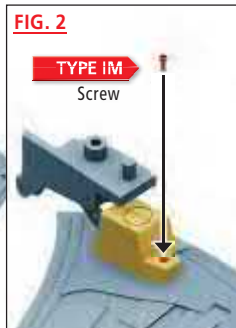



## STEP 04 Attach the Hood to the Front Body

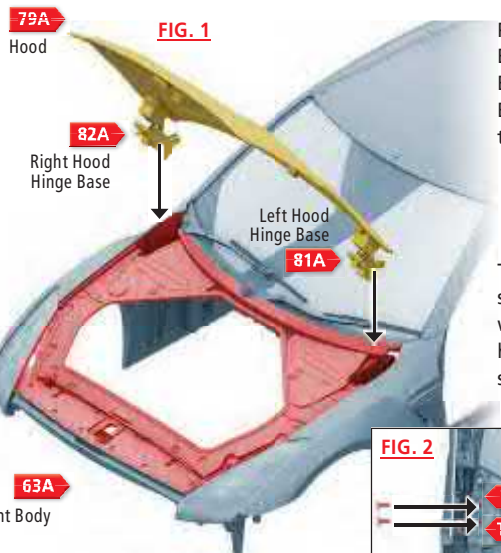

FIG. 1

Position the Hood [79A] onto the Front Body [63A], so that the Left Hood Hinge Base [81A] and the Right Hood Hinge Base [82A] fit into the areas shown by the black arrows in FIG.1 (left).

Then turn the entire Car Body over and secure both Hood Hinge Bases in place with two **TYPE AM** screws in the larger holes and two **TYPE MM** screws in the smaller holes, as shown in FIG.2 (below).



FIG. 2



## Complete!

### The Hood is complete

This is how the completed Hood should look once you have attached it to your model.





## THE LEFT DOOR

In this magazine, you will attach the Door Handle and Door Hinge to the Left Door of your NISSAN GT-R (R35) model.

### PARTS LOCATION

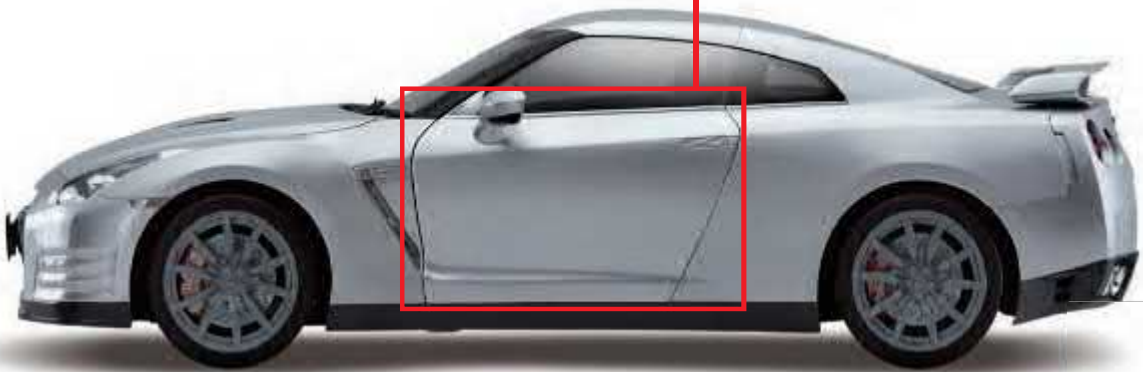

### PARTS LIST

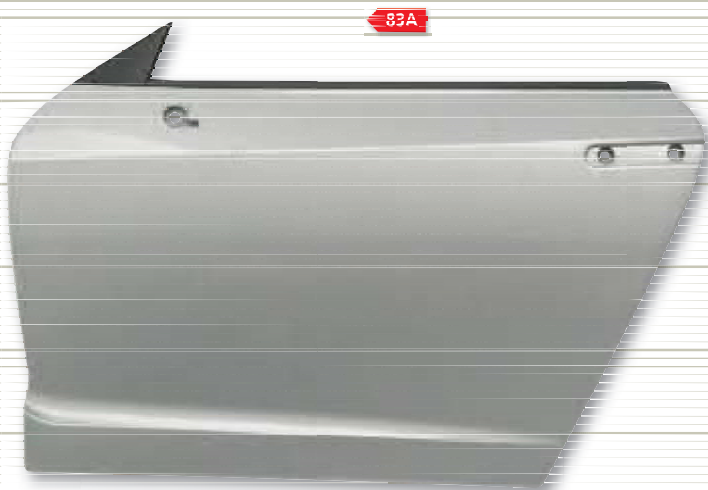

#### PART IDENTIFICATION LIST

PART No.	NAME	QUANTITY	MATERIAL
83A	Left Door	1	Zinc
83B	Left Door Handle	1	ABS
83C	Left Door Hinge	1	Zinc
83D	Left Door Hinge Holder	1	Fe
83E	Magnet Holder	1	ABS
83F	Magnet	1	Fe
Screws	Type BP 0.06 x 0.12" [1.5 x 3mm]	2 [+1 spare]	Metal
Screws	Type DM 0.08 x 0.12" [2 x 3mm]	1 [+1 spare]	Metal
Screws	Type NM 0.09 x 0.16" [2.3 x 4mm]	2 [+1 spare]	Metal



83B



83C

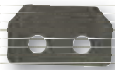

83D



83E



83F



TYPE BP



TYPE DM



TYPE NM

## STEP 01

### Attach the Magnet

Place the Magnet [83F] into the recess on the reverse side of the Left Door [83A], as shown in the illustration (right).



#### COLOR KEY

- PART BEING FITTED
- PART BEING FITTED TO
- FIXINGS

### STEP 01 COMPLETE



## STEP 02

### Secure the Magnet

FIG. 1

83A  
Left Door

Place the Door Opening Tool you received with magazine 20 on the area of the Left Door [83A] indicated by the red circle in FIG.1 to check that it is attracted to the Magnet. If it is not, you need to turn the Magnet around.

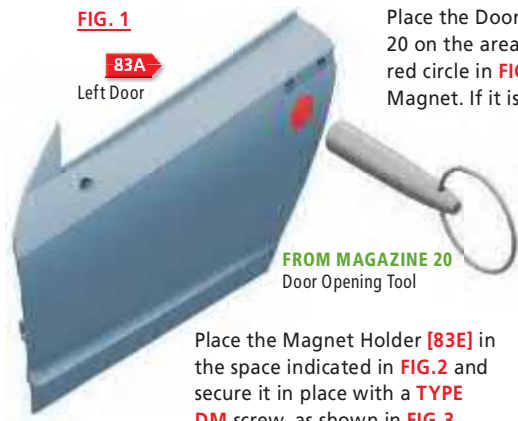

FROM MAGAZINE 20  
Door Opening Tool

Place the Magnet Holder [83E] in the space indicated in FIG.2 and secure it in place with a TYPE DM screw, as shown in FIG.3.

FIG. 2



83E  
Magnet Holder

FIG. 3



TYPE DM  
Screw

### STEP 02 COMPLETE



## STEP 03

### Attach the Left Door Handle

Fit the Left Door Handle [83B] onto the area of the Left Door's exterior [83A] shown in FIG.1.

FIG. 1



83A  
Left Door

83B  
Left Door  
Handle

FIG. 2



TYPE BP  
Screws

Secure the Left Door Handle [83B] from the inside of the Left Door with two TYPE BP screws, as shown in FIG.2.

### STEP 03 COMPLETE



## STEP 04 Attach the Left Door Hinge

Place the Left Door Hinge [83C] in the area shown on the illustration, which is on the inside of the Left Door [83A]. Make sure that the letter 'L', printed between the two pegs on the Left Door Hinge, is the correct way up and not upside down.



## STEP 05 Secure the Left Door Hinge Holder

FIG. 1

Place the Left Door Hinge Holder [83D] in the area indicated in FIG.1 and then secure it in place with two TYPE NM screws, as shown in FIG.2.

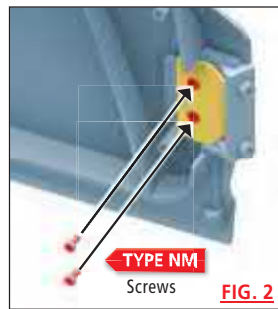
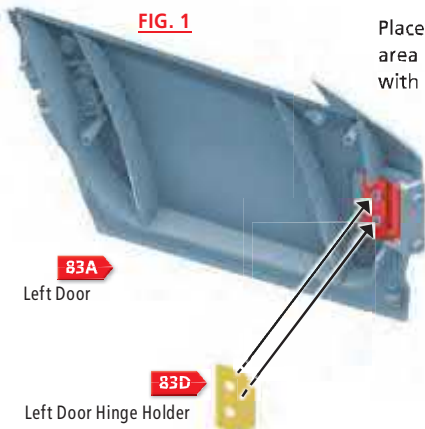

## Complete!

### The Left Door

This is how the Left Door should look from the outside and the inside once you have assembled these parts.



# THE LEFT WING MIRROR

Now you will assemble the Left Wing Mirror and attach it to your model's Left Door.



## PARTS LIST

### PART IDENTIFICATION LIST

PART No.	NAME	QUANTITY	MATERIAL
84A	Left Wing Mirror	1	Zinc
84B	Left Wing Mirror Surface	1	Photo Etch
Screws	Type GM 0.08 x 0.16" [2 x 4mm]	1 [+1 spare]	Metal



84A

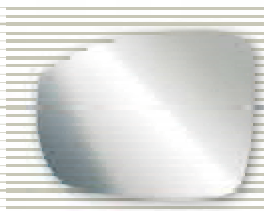

84B



TYPE GM

### TIP!

Ensure that you put the Left Wing Mirror Surface onto the Wing Mirror the correct way up.

## STEP 01 Attach the Left Wing Mirror Surface

Unpeel the label on the back of the Left Wing Mirror Surface [84B] to reveal its sticky side. Next, stick the Left Wing Mirror Surface to the Left Wing Mirror [84A], taking care to attach it the correct way round.

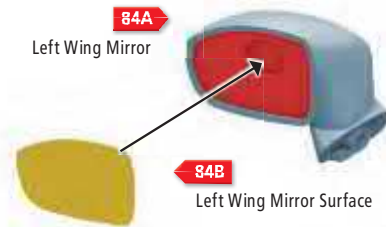

### COLOR KEY

- PART BEING FITTED
- PART BEING FITTED TO
- FIXINGS



## STEP 02 Attach the Left Wing Mirror to the Left Door

Position the Left Wing Mirror [84A] so that the screw hole on the side of it fits snugly inside the hole on the Left Door [83A], as indicated in the illustration.

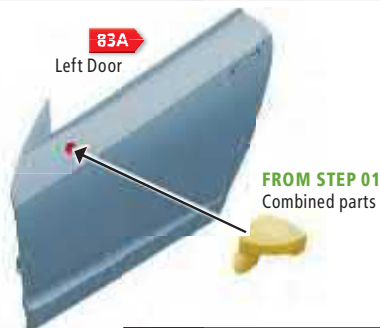

## STEP 03 Secure the Left Wing Mirror to the Left Door

Holding the Left Wing Mirror [84A] firmly in place, use a TYPE GM screw in the hole on the inside of the Left Door [83A], as shown in the illustration, to secure it in position.



## Complete!

### The Left Wing Mirror

This is how the Left Wing Mirror should look once you have attached it to your model's Left Door.

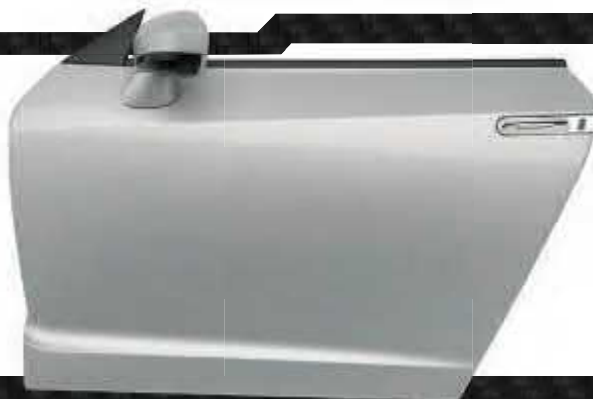

# THE LEFT DOOR PANEL

Next, you will assemble the Left Door Panel of your NISSAN GT-R (R35) model.

## PARTS LOCATION

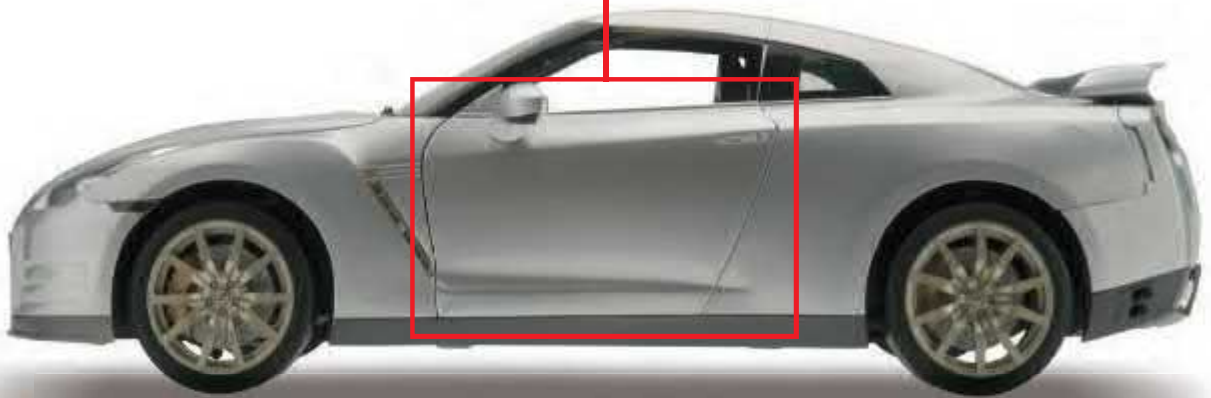

## PARTS LIST

### PART IDENTIFICATION LIST

PART No.	NAME	QUANTITY	MATERIAL
85A	Left Door Panel	1	ABS
85B	Left Door Panel Outlet	1	ABS
85C	Left Electric Window Switch	1	ABS
85D	Left Door Panel Handle	1	ABS
85E	Left Door Storage Panel	1	Photo Etch
Screws	Type GP 0.08 x 0.16" [2 x 4mm]	2 [+1 spare]	Metal

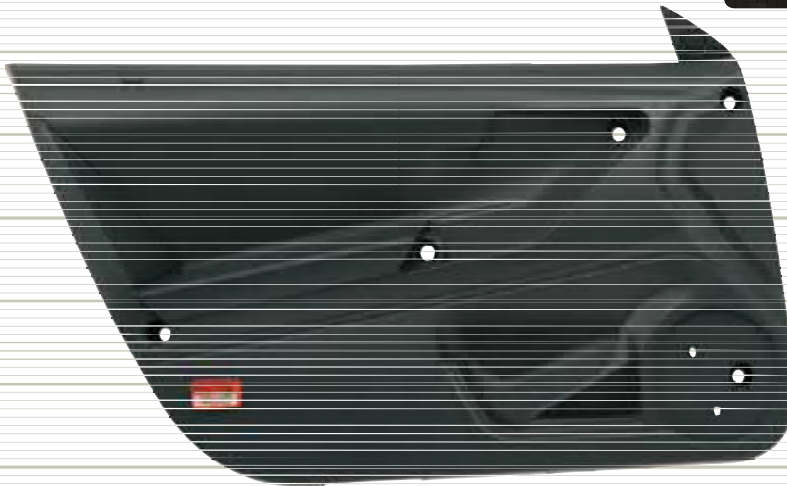



## STEP 01 Attach the Left Door Panel Outlet

Push the two pegs on the bottom of the Left Door Panel Outlet [85B] into the two holes on the top of the Left Door Panel [85A], shown in the illustration. This part just pushes securely into place and there is no need for screws.



### COLOR KEY

- PART BEING FITTED
- PART BEING FITTED TO
- FIXINGS



## STEP 02 Attach the Left Electric Window Switch

Push the two pegs on the bottom of the Left Electric Window Switch [85C] into the two holes on the Left Door Panel Handle [85D], as indicated in the illustration. This part just pushes securely into place and there is no need for screws.

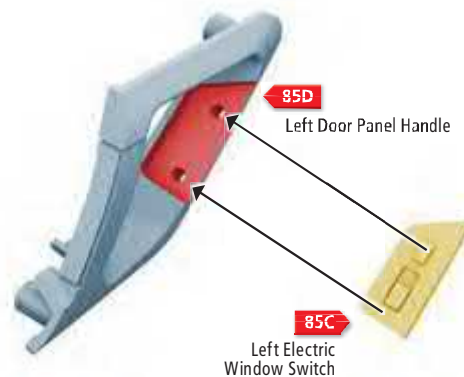

## STEP 03 Attach the Left Door Panel Handle

Push the two pegs on the reverse side of the Left Door Panel Handle [85D] into the two holes on the Left Door Panel [85A], as shown in the illustration.

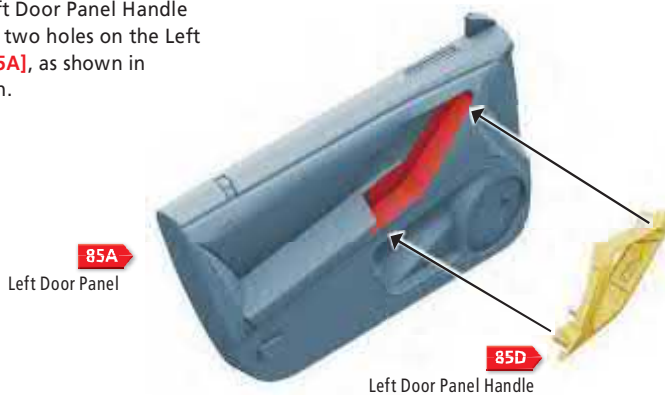

## STEP 04

### Secure the Left Door Panel Handle

From the inside of the Left Door Panel [85A] secure the Left Door Panel Handle [85D] in place with two **TYPE GP** screws in the holes shown in the illustration.

**85A**  
Left Door Panel

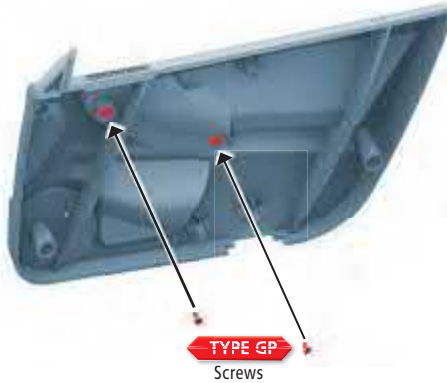

STEP 04 COMPLETE



## STEP 05

### Attach the Left Door Storage Panel

Remove the strips on the back of the Left Door Storage Panel [85E] and stick it firmly onto the Left Door Panel [85A] in the position indicated in red on the illustration.

**85A**  
Left Door Panel



STEP 05 COMPLETE



## Complete!

### The Left Door Panel

This is how the Left Door Panel should look once you have assembled these parts.



## THE LEFT DOOR WINDOW

Now you will assemble the mechanism for the Left Door Window and attach the Left Door to the Car Body of your NISSAN GT-R (R35) model. The mechanism can be a bit tricky, so take your time.

### PARTS LOCATION

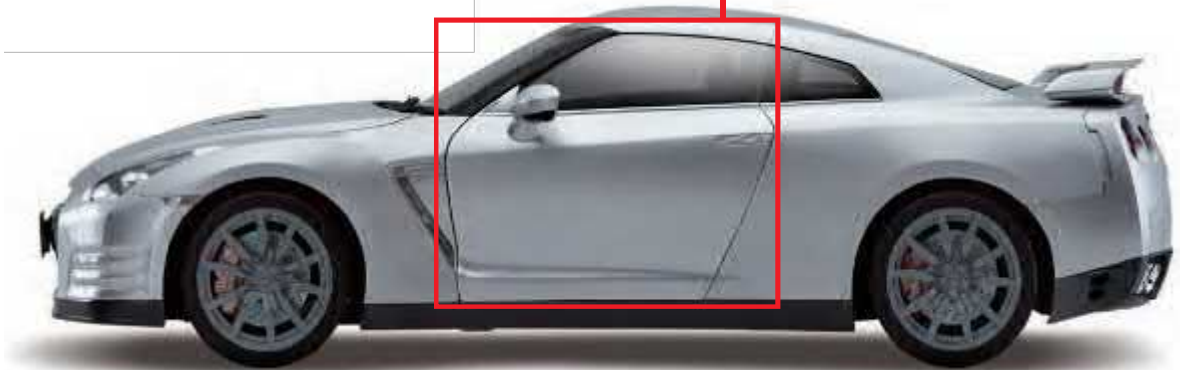

### PARTS LIST

#### PART IDENTIFICATION LIST

PART No.	NAME	QUANTITY	MATERIAL
86A	Left Window	1	GP
86B	Window String	1	Nylon
86C	Small Gear A	2	ABS
86D	Small Gear B	2	ABS
86E	Big Gear A	1	ABS
86F	Big Gear B	1	ABS
86G	Left Door Speaker	1	ABS
Screws	Type IP 0.07 x 0.12" [1.7 x 3mm]	3 [+3 spare]	Metal
Screws	Type GM 0.8 x 0.16" [2 x 4mm]	3 [+1 spare]	Metal
Screws	Type AM 0.1 x 0.16" [2.6 x 4mm]	2 [+1 spare]	Metal



86A



86B



86C



86D



86E



86F



86G



TYPE IP



TYPE GM



TYPE AM

## STEP 01

### Combine Small Gear A with Small Gear B

Combine Small Gear A [86C] with Small Gear B [86D] by pushing the parts together, as shown in the illustration. Now do the same with the second identical Small Gear A and Small Gear B. The parts just push together and do not require screws.

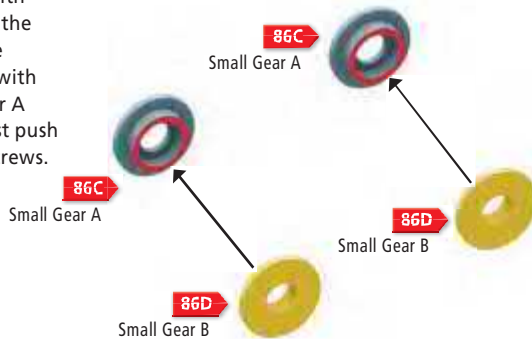

#### COLOR KEY

- PART BEING FITTED
- PART BEING FITTED TO
- FIXINGS



## STEP 02

### Combine Big Gear A with Big Gear B

Combine Big Gear A [86E] with Big Gear B [86F] by pushing the parts together, as shown in the illustration. Make sure the two struts on the back of Big Gear A fit inside the two holes on either side of the center hole on Big Gear B. The parts just push together and no screws are required.

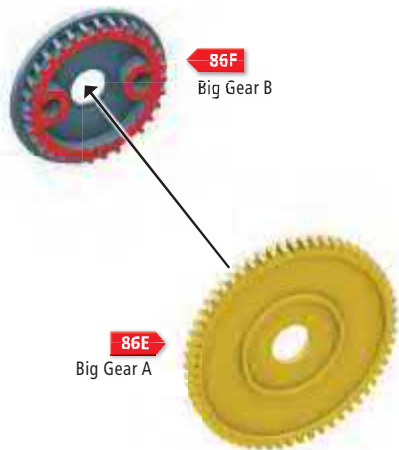

## STEP 03

### Attach the Big and Small Gears to the Left Door Panel

Attach both combined Small Gears [86C/D] and the combined Big Gear [86E/F] to the areas on the inside of the Left Door Panel [85A] indicated in the illustration. All three of the combined Gears are attached using TYPE IP screws.

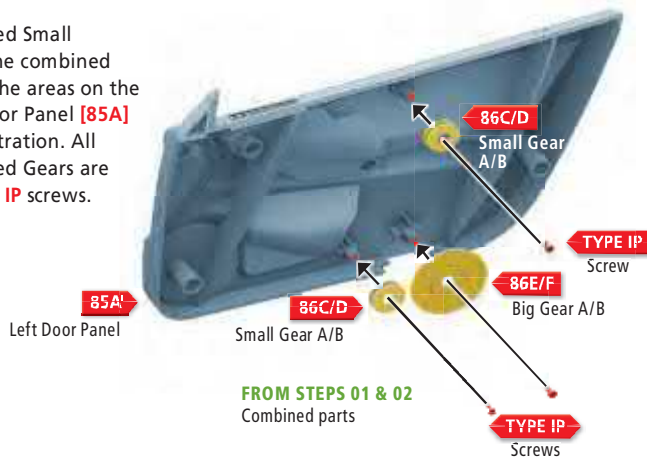

## STEP 04 Attach the Window String

Tie a knot near one end of the Window String [86B] and then thread the other end of the Window String through the hole nearest the bottom of the Left Window [86A], as shown in FIG.1 (right).

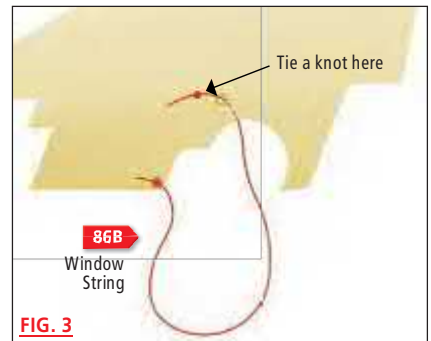
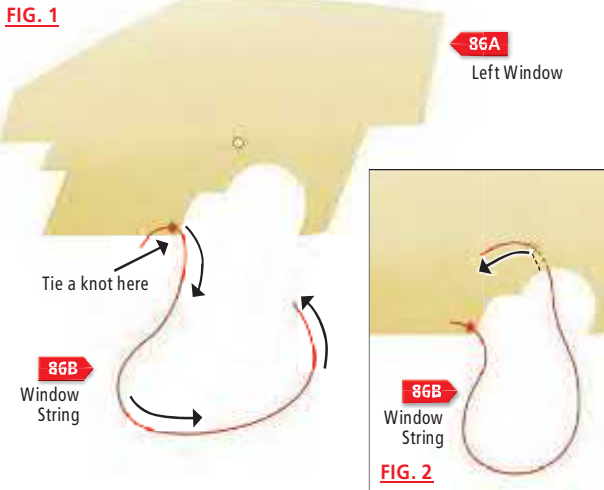

Thread the other end of the Window String under the Left Window and up through the second hole, as shown in FIG.2 (left), before tying another knot near the end of the Window String, as shown in FIG.3 (above).

## STEP 05 Wind the Window String around the Small and Big Gears

1. Wind the Window String [86B] over the Small Gear A/B [86C/D] that is positioned near the top of the Left Door Panel [85A], as shown by the white arrow in FIG.1.

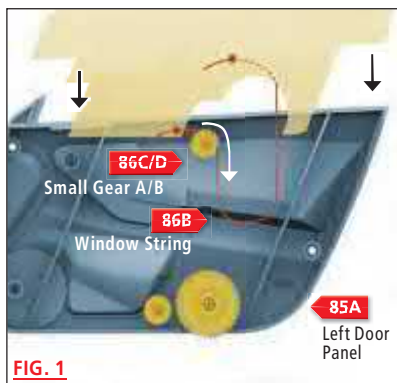

2. Now take the Window String [86B] down and under the lower Small Gear A/B [86C/D] and then wind it twice around the Big Gear E/F, as shown in FIG.2 (right).

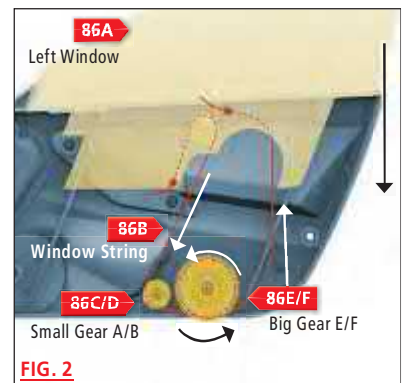

3. Make sure the thin plastic strips on the Left Door Panel [85A] – next to the white arrows shown in FIG.3 – slot between the runners on the Left Window [86A].

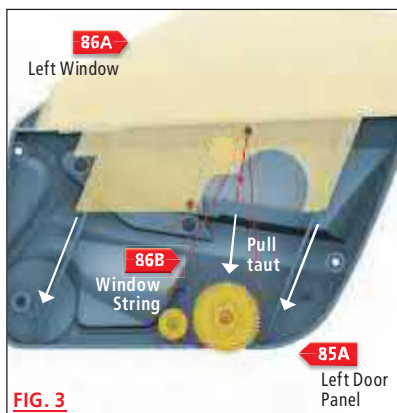

Next, gently pull the end of the Window String [86B] until it is taut, close to the upper hole.

4. Still gently pulling the Window String [86B] taut, tie another knot next to the upper hole on the Left Window [86A], as shown in FIG.4 (right).

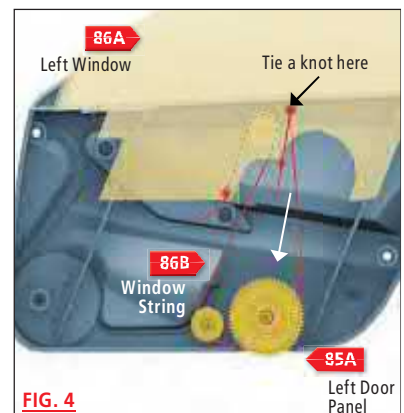

5. Still pulling the Window String [86B] taut, tie a second knot over the first knot – next to the upper hole in the Left Window [86A] – as shown in FIG. 5.

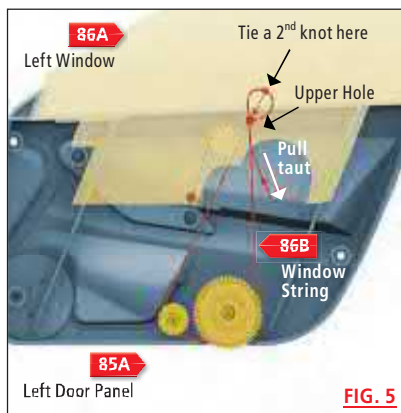

6. Now test that the window winding mechanism works by using your thumb to gently turn the Big Gear at the bottom back and forth to make the window go up and down, as shown in FIG. 6.

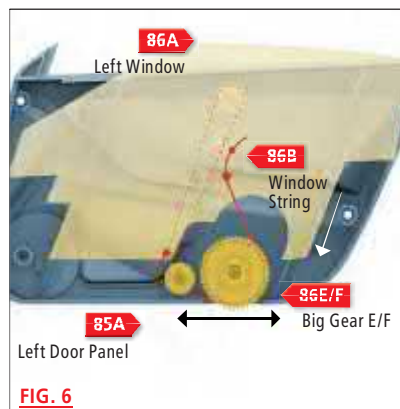

## STEP 06 Attach the Left Door Panel to the Left Door

Push the Left Door Panel [85A] onto the Left Door [83A], so that the three screw holes line up with the three struts indicated by the arrows in FIG. 1. Secure the parts together with three TYPE GM screws, as shown in FIG. 2.

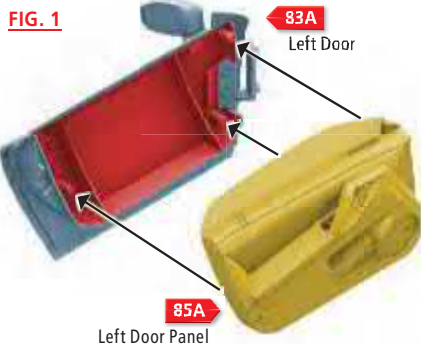

## STEP 07 Attach the Left Door Speaker

Push the two struts on the back of the Left Door Speaker [86G] into the two holes on the Left Door Panel [85A], as indicated by the highlighted area of the illustration.

FROM STEP 06  
Combined parts



### TIP!

Make sure the window winding mechanism works before adding the Left Door Speaker, as this part is difficult to remove.

# HOW TO BUILD

## STEP 08 Attach the Left Door and Window to the Car Body

Push the two struts of the Left Door Hinge [83C] into the two holes on the Car Body, indicated by the black arrows on the illustration.



STEP 08 COMPLETE



## STEP 09 Secure the Left Door and Window to the Car Body

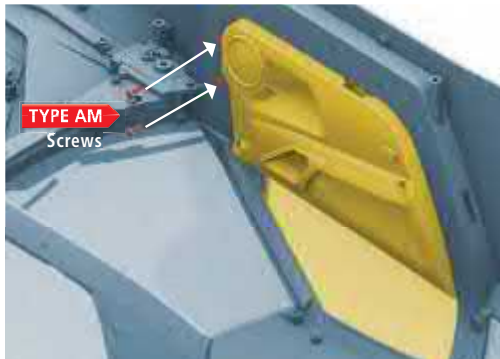

Holding the Left Door Hinge [83C] firmly in place, secure the combined Left Door and Window to the Car Body with two TYPE AM screws in the holes shown in the illustration.

STEP 09 COMPLETE



## Complete! The Left Door and Window

This is how the Left Door and Window should look once you have attached the parts to the Car Body.







## THE RIGHT DOOR

In this magazine, you will attach the Door Handle and Hinge to the Right Door of your NISSAN GT-R (R35) model.

### PARTS LOCATION

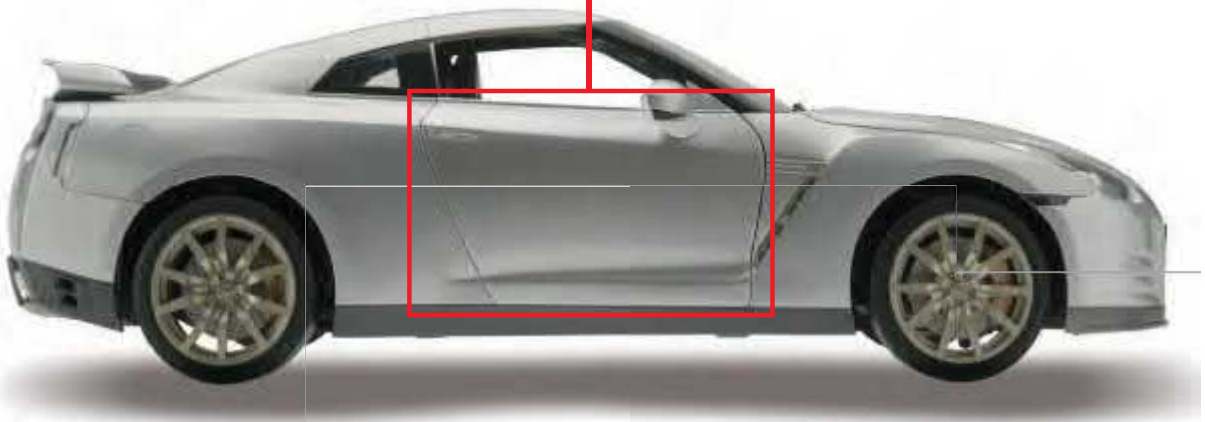

### PARTS LIST

#### PART IDENTIFICATION LIST

PART No.	NAME	QUANTITY	MATERIAL
87A	Right Door	1	Zinc
87B	Right Door Handle	1	ABS
87C	Right Door Hinge	1	Zinc
87D	Right Door Hinge Holder	1	Fe
87E	Magnet Holder	1	ABS
87F	Magnet	1	Fe
Screws	Type BP 0.06 x 0.12" [1.5 x 3mm]	2 [+1 spare]	Metal
Screws	Type DM 0.08 x 0.12" [2 x 3mm]	1 [+1 spare]	Metal
Screws	Type NM 0.09 x 0.16" [2.3 x 4mm]	2 [+1 spare]	Metal



87A



87B



87C

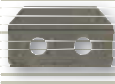

87D



87E



87F



TYPE BP



TYPE DM



TYPE NM

## STEP 01

### Attach the Magnet

Place the Magnet [87F] into the recess on the reverse side of the Right Door [87A], as shown in the illustration (right).



#### COLOR KEY

- PART BEING FITTED
- PART BEING FITTED TO
- FIXINGS



## STEP 02

### Secure the Magnet

FIG. 1



Place the Door Opening Tool you received with magazine 20 on the area of the Right Door [87A] indicated by the red circle in FIG.1 to check that it is attracted to the Magnet. If it is not, you need to turn the Magnet around.

FIG. 2



FIG. 3



Place the Magnet Holder [87E] in the space indicated in FIG.2 and secure it in place with a TYPE DM screw, as shown in FIG.3.



## STEP 03

### Attach the Right Door Handle

Fit the Right Door Handle [87B] onto the area of the Right Door's exterior [87A] shown in FIG.1.

FIG. 1

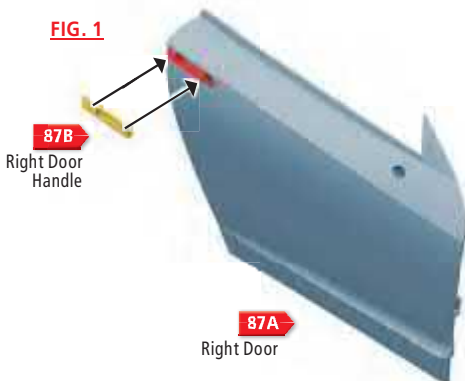
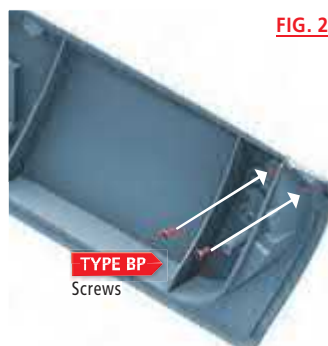

FIG. 2



Secure the Right Door Handle [87B] from the inside of the Right Door with two TYPE BP screws, as shown in FIG.2.



## STEP 04 Attach the Right Door Hinge

Place the Right Door Hinge [87C] in the area shown on the illustration, which is on the inside of the Right Door [87A]. Make sure that the letter 'R', printed between the two pegs on the Right Door Hinge, is the correct way up and not upside down.



## STEP 05 Secure the Right Door Hinge Holder

FIG. 1

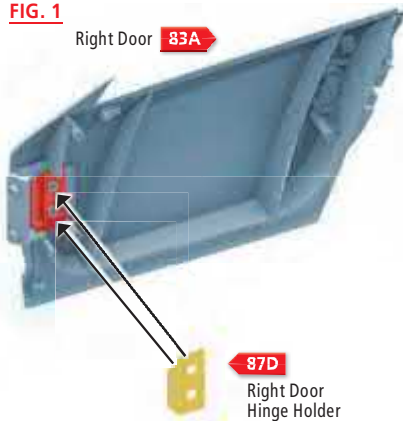

Place the Right Door Hinge Holder [87D] in the area indicated in FIG.1 and then secure it in place with two TYPE NM screws, as shown in FIG.2.

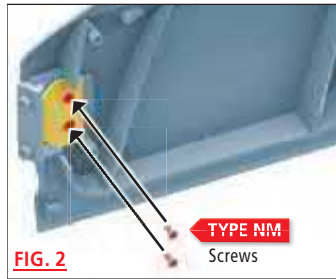

## Complete!

### The Right Door

This is how the Right Door should look from the outside and the inside once you have assembled these parts.



# THE RIGHT WING MIRROR

Now you will assemble the Right Wing Mirror and attach it to your model's Right Door.

## PARTS LOCATION



## PARTS LIST

### PART IDENTIFICATION LIST

PART No.	NAME	QUANTITY	MATERIAL
88A	Right Wing Mirror	1	Zinc
88B	Right Wing Mirror Surface	1	Photo Etch
Screws	Type GM 0.08 x 0.16" [2 x 4mm]	1 [+1 spare]	Metal



88A



88B



TYPE GM

### TIP!

Ensure that you put the Right Wing Mirror Surface onto the Wing Mirror the correct way up.

# HOW TO BUILD

## STEP 01 Attach the Right Wing Mirror Surface

Unpeel the label on the back of the Right Wing Mirror Surface [88B] to reveal its sticky side. Next, stick the Right Wing Mirror Surface to the Right Wing Mirror [88A], taking care to attach it the correct way round.

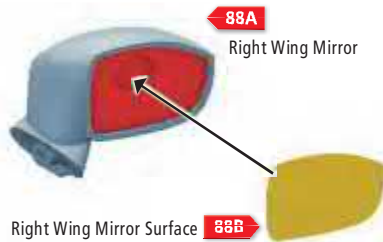

**COLOR KEY**  
■ PART BEING FITTED  
■ PART BEING FITTED TO  
■ FIXINGS



## STEP 02 Attach the Right Wing Mirror to the Right Door

Position the Right Wing Mirror [88A] so that the screw hole on the side of it fits snugly inside the hole on the Right Door [87A], as indicated in the illustration.

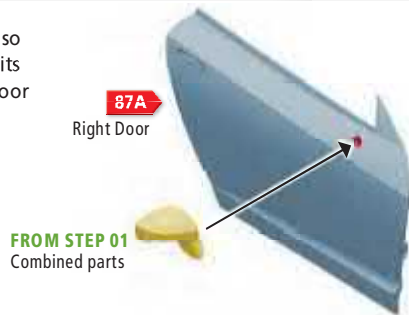

## STEP 03 Secure the Right Wing Mirror to the Right Door

Holding the Right Wing Mirror [88A] firmly in place, use a TYPE GM screw in the hole on the inside of the Right Door [87A], as shown in the illustration, to secure it in position.

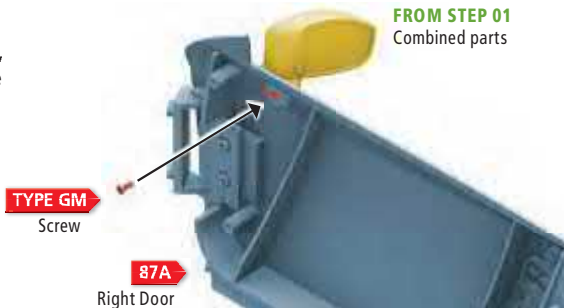

## Complete!

### The Right Wing Mirror

This is how the Right Wing Mirror should look once you have attached it to your model's Right Door.



# THE RIGHT DOOR PANEL

Next, you will assemble the Right Door Panel of your NISSAN GT-R (R35) model.

## PARTS LOCATION



## PARTS LIST

### PART IDENTIFICATION LIST

PART No.	NAME	QUANTITY	MATERIAL
89A	Right Door Panel	1	ABS
89B	Right Door Panel Outlet	1	ABS
89C	Right Electric Window Switch	1	ABS
89D	Right Panel Door Handle	1	ABS
89E	Right Door Storage Panel	1	Photo Etch
Screws	Type GP 0.08 x 0.16"	2 [+1 spare]	Metal [2 x 4mm]



## STEP 01 Attach the Right Door Panel Outlet

Push the two pegs on the bottom of the Right Door Panel Outlet [89B] into the two holes on the top of the Right Door Panel [89A], shown in the illustration. This part just pushes securely into place and there is no need for screws.



### COLOR KEY

- PART BEING FITTED
- PART BEING FITTED TO
- FIXINGS

### STEP 01 COMPLETE



## STEP 02 Attach the Right Electric Window Switch

Push the two pegs on the bottom of the Right Electric Window Switch [89C] into the two holes on the Right Door Panel Handle [89D], as indicated in the illustration. This part just pushes securely into place and there is no need for screws.

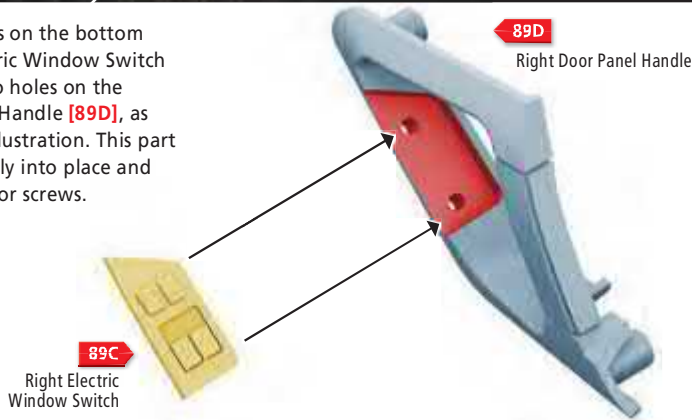

### STEP 02 COMPLETE



## STEP 03 Attach the Right Door Panel Handle

Push the two pegs on the reverse side of the Right Door Panel Handle [89D] into the two holes on the Right Door Panel [89A], as shown in the illustration.

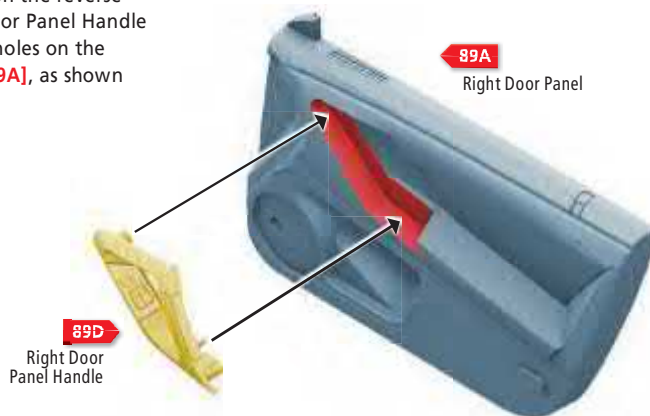

### STEP 03 COMPLETE



## STEP 04

### Secure the Right Door Panel Handle

From the inside of the Right Door Panel [89A] secure the Right Door Panel Handle [89D] in place with two **TYPE GP** screws in the holes shown in the illustration.

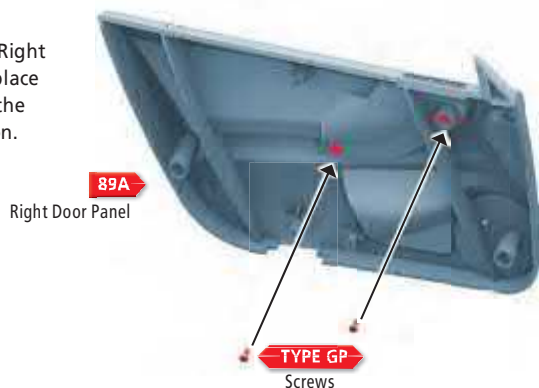

### STEP 04 COMPLETE



## STEP 05

### Attach the Right Door Storage Panel

Remove the strips on the back of the Right Door Storage Panel [89E] and stick it firmly onto the Right Door Panel [89A] in the position indicated in red on the illustration.

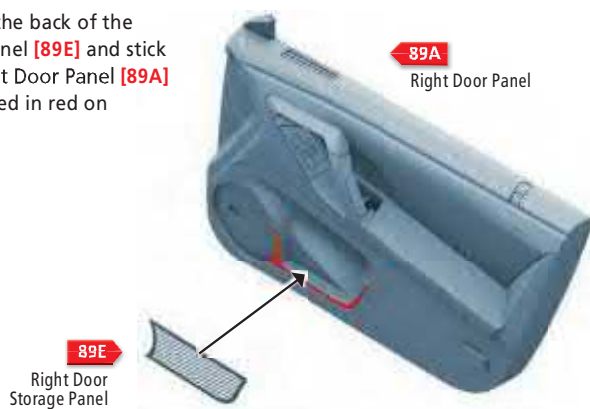

### STEP 05 COMPLETE



## Complete!

### The Right Door Panel

This is how the Right Door Panel should look once you have assembled these parts.





## THE RIGHT DOOR WINDOW

Now you will assemble the mechanism for the Right Door Window and attach the Right Door to the Car Body of your NISSAN GT-R (R35) model. The mechanism can be a bit tricky, so take your time.

### PARTS LOCATION



### PARTS LIST

#### PART IDENTIFICATION LIST

PART No.	NAME	QUANTITY	MATERIAL
90A	Right Window	1	GP
90B	Window String	1	Nylon
90C	Small Gear A	2	ABS
90D	Small Gear B	2	ABS
90E	Big Gear A	1	ABS
90F	Big Gear B	1	ABS
90G	Right Door Speaker	1	ABS
Screws	Type IP 0.07 x 0.12" [1.7 x 3mm]	3 [+3 spare]	Metal
Screws	Type GM 0.8 x 0.16" [2 x 4mm]	3 [+1 spare]	Metal
Screws	Type AM 0.1 x 0.16" [2.6 x 4mm]	2 [+1 spare]	Metal



90A



90B



90C



90D



90E



90F



90G



TYPE IP



TYPE GM



TYPE AM

## STEP 01

### Combine Small Gear A with Small Gear B

Combine Small Gear A [90C] with Small Gear B [90D] by pushing the parts together, as shown in the illustration. Now do the same with the second identical Small Gear A and Small Gear B. The parts just push together and do not require screws.

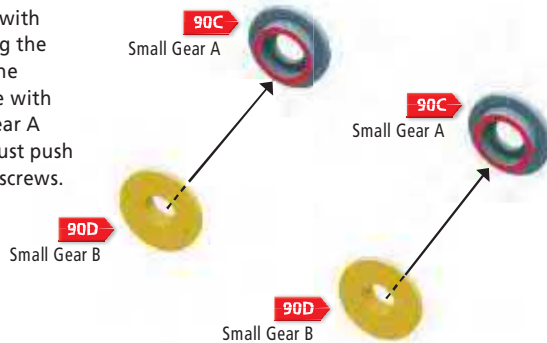

#### COLOR KEY

- PART BEING FITTED
- PART BEING FITTED TO
- FIXINGS



## STEP 02

### Combine Big Gear A with Big Gear B

Combine Big Gear A [90E] with Big Gear B [90F] by pushing the parts together, as shown in the illustration. Make sure the two struts on the back of Big Gear A fit inside the two holes on either side of the center hole on Big Gear B. The parts just push together and no screws are required.

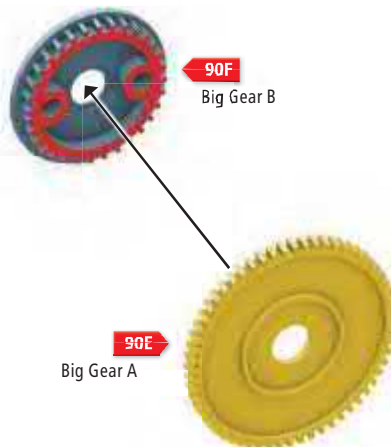

## STEP 03

### Attach the Big and Small Gears to the Right Door Panel

Attach both combined Small Gears [90C/D] and the combined Big Gear [90E/F] to the areas on the inside of the Right Door Panel [89A] indicated in the illustration. All three of the combined Gears are attached using TYPE IP screws.

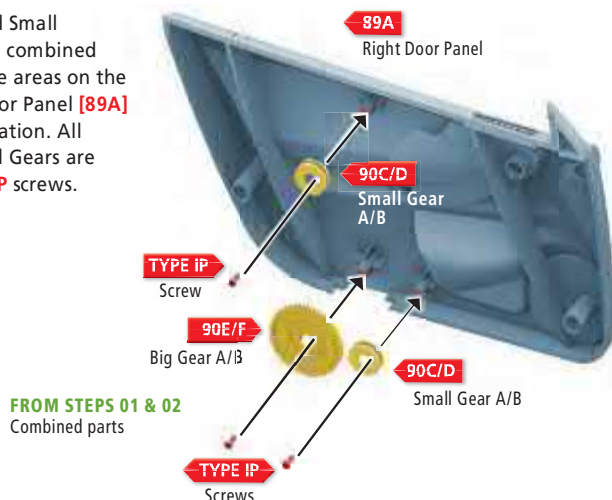

## STEP 04 Attach the Window String

Tie a knot near one end of the Window String [90B] and then thread the other end of the Window String through the hole nearest the bottom of the Right Window [90A], as shown in FIG.1 (right).

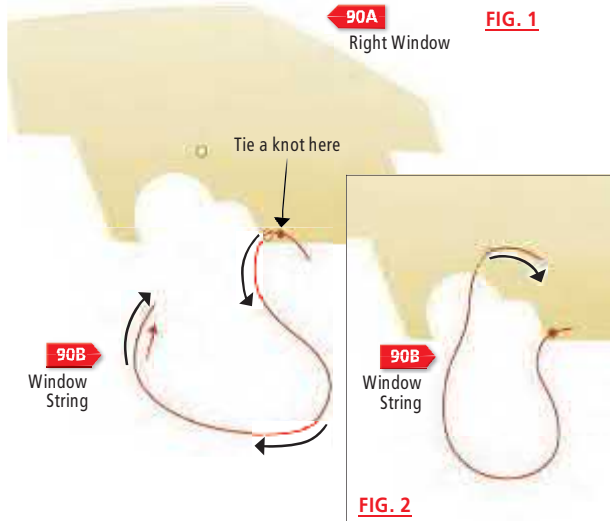

Thread the other end of the Window String under the Right Window and up through the second hole, as shown in FIG.2 (left), before tying another knot near the end of the Window String, as shown in FIG.3 (above).

## STEP 05 Wind the Window String around the Small and Big Gears

1. Wind the Window String [90B] over the Small Gear A/B [90C/D] that is positioned near the top of the Right Door Panel [89A], as shown by the white arrow in FIG.1.

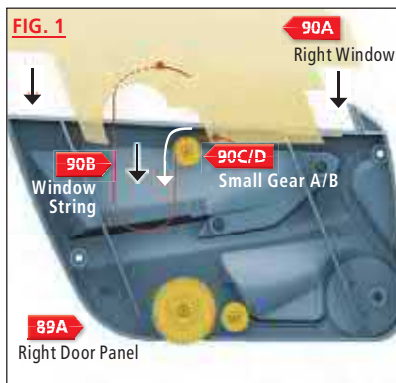

2. Now take the Window String [90B] down and under the lower Small Gear A/B [90C/D] and then wind it twice around the Big Gear E/F, as shown in FIG.2 (right).



3. Make sure the thin plastic strips on the Right Door Panel [89A] – next to the white arrows shown in FIG.3 – slot between the runners on the Right Window [90A].

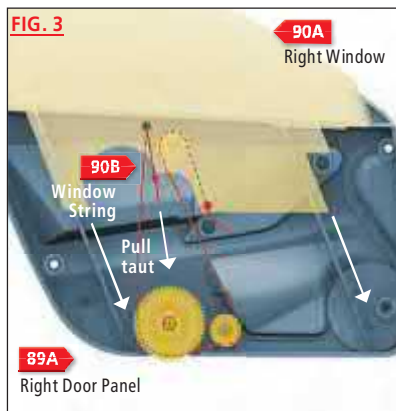

Next, gently pull the end of the Window String [90B] until it is taut, close to the upper hole.

4. Still gently pulling the Window String [90B] taut, tie another knot next to the upper hole on the Right Window [90A], as shown in FIG.4 (right).

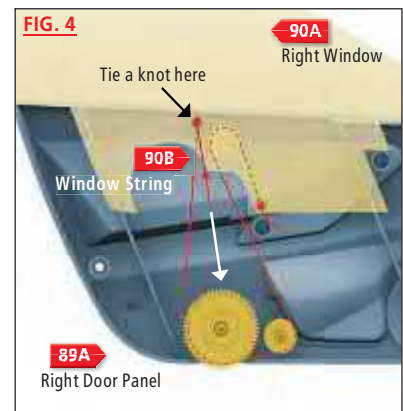

5. Still pulling the Window String [90B] taut, tie a second knot over the first knot – next to the upper hole in the Right Window [90A] – as shown in FIG. 5.

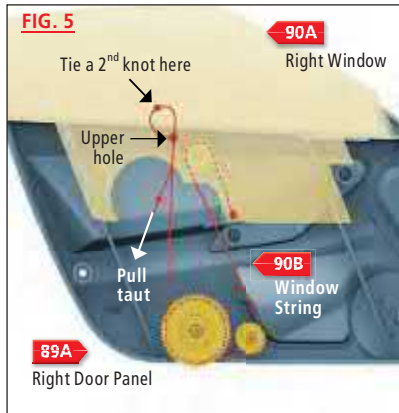

6. Now test that the window winding mechanism works by using your thumb to gently turn the Big Gear at the bottom back and forth to make the window go up and down, as shown in FIG. 6.

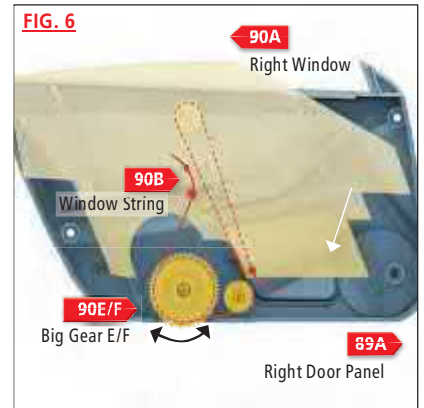

## STEP 06 Attach the Right Door Panel to the Right Door

Push the Right Door Panel [89A] onto the Right Door [87A], so that the three screw holes line up with the three struts indicated by the arrows in FIG. 1. Secure the parts together with three TYPE GM screws, as shown in FIG. 2.

FIG. 1

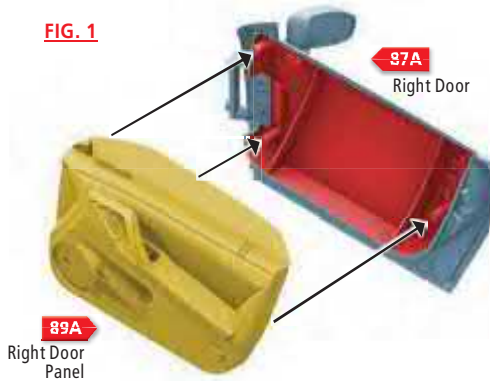
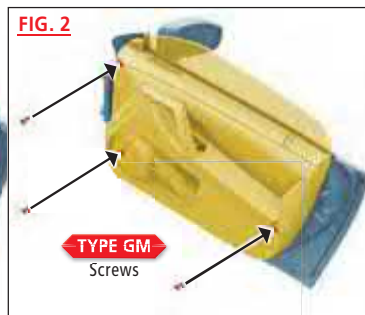

FIG. 2



### STEP 06 COMPLETE



## STEP 07 Attach the Right Door Speaker

Push the two struts on the back of the Right Door Speaker [90G] into the two holes on the Right Door Panel [89A], as indicated by the highlighted area of the illustration.

FROM STEP 06  
Combined parts

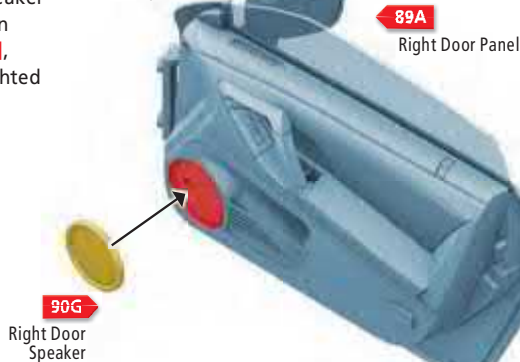

### TIP!

Make sure the window winding mechanism works before adding the Right Door Speaker, as this part is difficult to remove.

### STEP 07 COMPLETE



## STEP 08 Attach the Right Door and Window to the Car Body

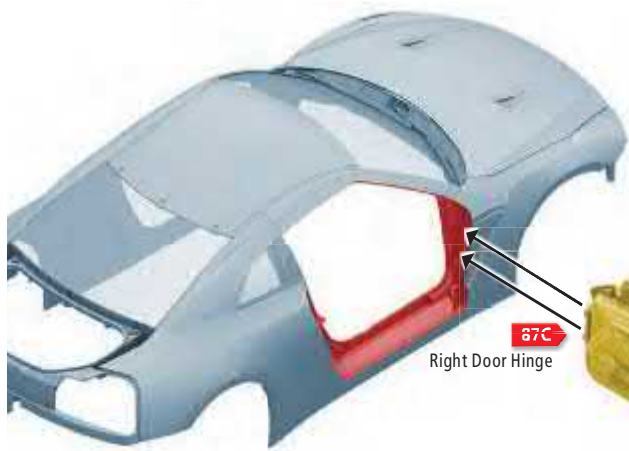

Push the two struts of the Right Door Hinge [87C] into the two holes on the Car Body, indicated by the black arrows on the illustration.



## STEP 09 Secure the Right Door and Window to the Car Body

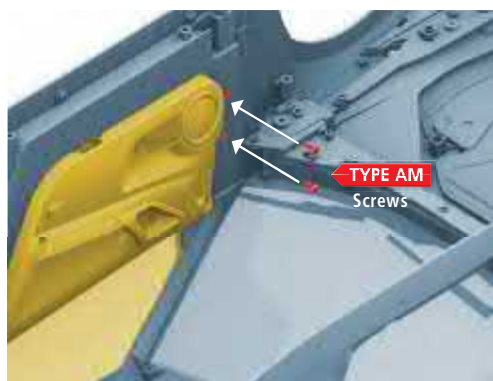

Holding the Right Door Hinge [87C] firmly in place, secure the combined Right Door and Window to the Car Body with two TYPE AM screws in the holes shown in the illustration.



## Complete! The Right Door Window

This is how the Right Door and Window should look once you have attached the parts to the Car Body.





# HOW TO BUILD

## THE TRUNK LID

In this magazine, you will attach the Nissan Badge to the Trunk Lid of your NISSAN GT-R (R35) model.

### PARTS LOCATION



### PARTS LIST

#### PART IDENTIFICATION LIST

PART No.	NAME	QUANTITY	MATERIAL
91A	Trunk Lid	1	Zinc
91B	Nissan Badge	1	ABS

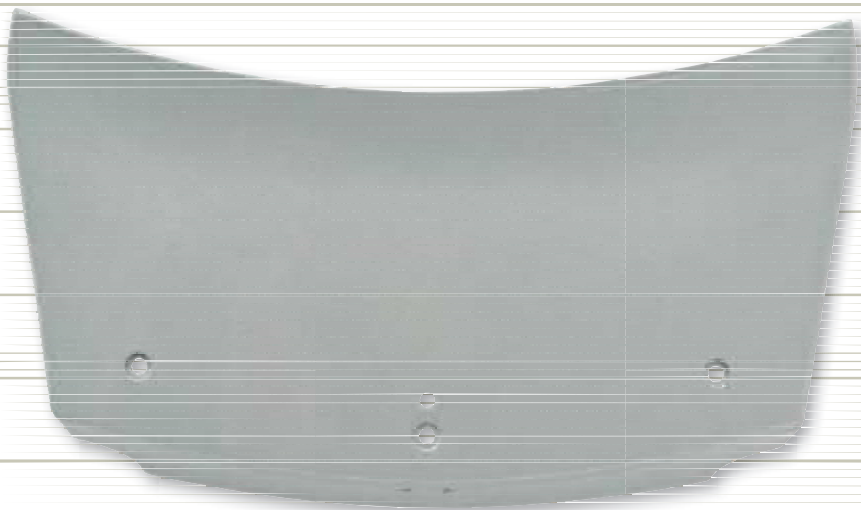

## STEP 01

### Attach the Nissan Badge to the Trunk Lid

#### COLOR KEY

- PART BEING FITTED
- PART BEING FITTED TO
- FIXINGS

Push the two struts on the back of the Nissan Badge [91B] into the two holes on the Trunk Lid [91A], as indicated in the illustration. This part just pushes into place and no screws are required.

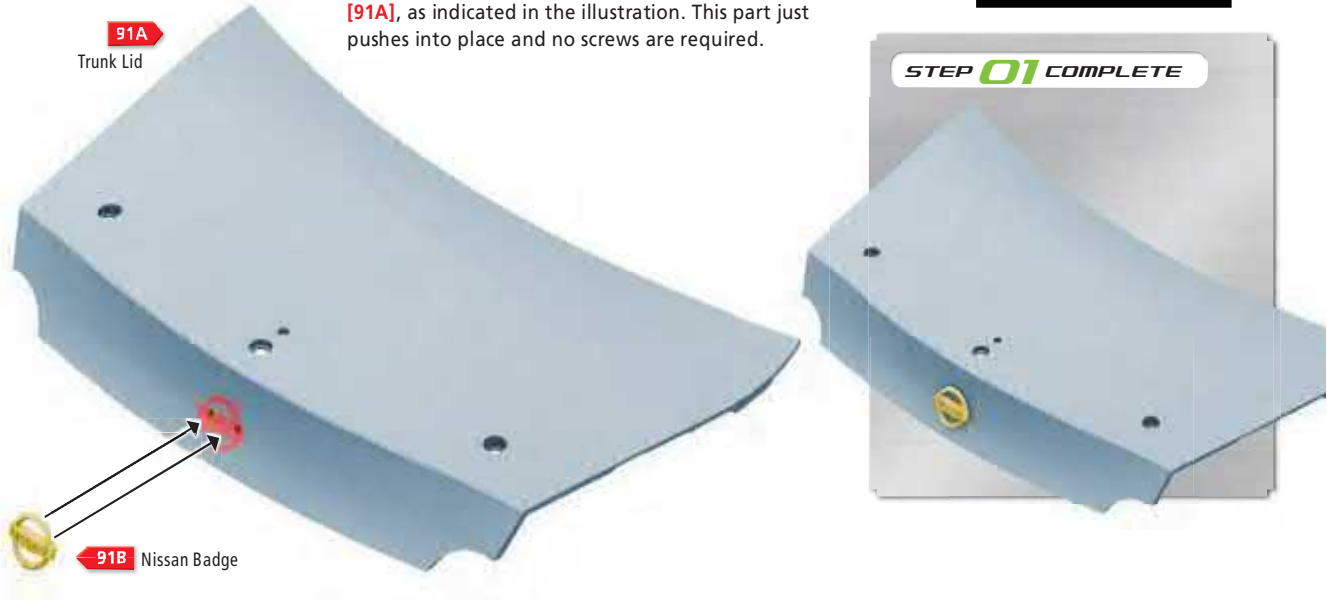

## Complete!

### The Trunk Lid

This is how the Trunk Lid should look once you have attached the Nissan Badge to it.





## THE REAR SPOILER

Now you will assemble the Rear Spoiler and attach it to your model's Trunk Lid.

**PARTS LOCATION**



### PARTS LIST



TYPE HM

#### PART IDENTIFICATION LIST

PART No.	NAME	QUANTITY	MATERIAL
92A	Rear Spoiler	1	Zinc
92B	Rear Spoiler Strut	1	Zinc
92C	Rear Spoiler Brake Light	1	GP
Screws	Type HM 0.09 x 0.16" [2.3 x 4mm]	3 [+2 spare]	Metal



92B



92C

## STEP 01

### Attach the Rear Spoiler Brake Light

Push the two pegs on the bottom of the Rear Spoiler Brake Light [92C] into the two holes on the underside of the Rear Spoiler [92A], as indicated in the illustration. This part just pushes securely into place and there is no need for screws.

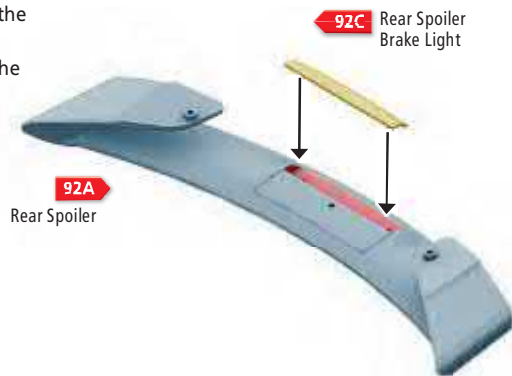

#### COLOR KEY

- PART BEING FITTED
- PART BEING FITTED TO
- FIXINGS

#### STEP 01 COMPLETE



## STEP 02

### Attach the Rear Spoiler Strut

Push the peg and screw hole on the base of the Rear Spoiler Strut [92B] into the two holes on the top of the Trunk Lid [91A], as shown in the illustration.

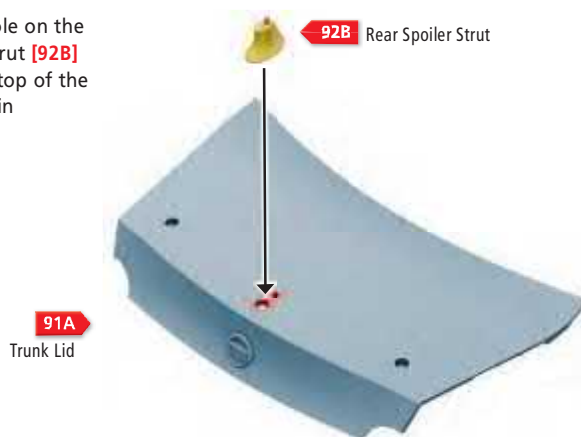

#### STEP 02 COMPLETE



## STEP 03

### Secure the Rear Spoiler Strut

Holding the Rear Spoiler Strut [92B] firmly in position, turn the Trunk Lid [91A] over and secure the Rear Spoiler Strut to the Trunk Lid with a TYPE HM screw, as shown in the illustration.

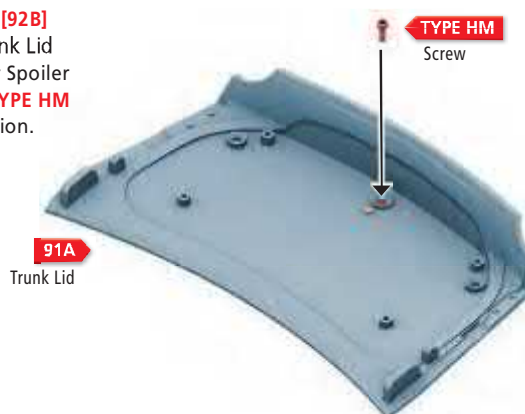

#### STEP 03 COMPLETE



## STEP 04 Attach the Rear Spoiler to the Trunk Lid

Position the Rear Spoiler [92A] on top of the Trunk Lid [91A], as shown in the illustration, ensuring that the peg on top of the Rear Spoiler Strut [92B] fits into the center hole on the underside of the Rear Spoiler.

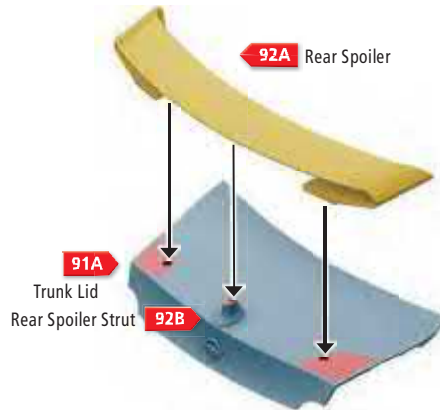

## STEP 05 Secure the Rear Spoiler to the Trunk Lid

Holding the Rear Spoiler [92A] firmly in place, turn the Trunk Lid [91A] over and secure the Rear Spoiler to the Trunk Lid with two TYPE HM screws in the holes indicated in the illustration.



## Complete!

### The Rear Spoiler

This is how the Rear Spoiler should look once you have attached it to the Trunk Lid.



# THE TRUNK LID INNER TRIM

Next, you will attach the Trunk Lid Inner Trim to your NISSAN GT-R (R35) model.

## PARTS LOCATION



## PARTS LIST



TYPE GM

93A

### PART IDENTIFICATION LIST

PART No.	NAME	QUANTITY	MATERIAL
93A	Trunk Lid Inner Trim	1	ABS
Screws	TYPE GM 0.08 x 0.16" [2 x 4mm]	4 [+1 spare]	Metal



## STEP 01

### Attach the Trunk Lid Inner Trim

#### COLOR KEY

- PART BEING FITTED
- PART BEING FITTED TO
- FIXINGS

FIG. 1

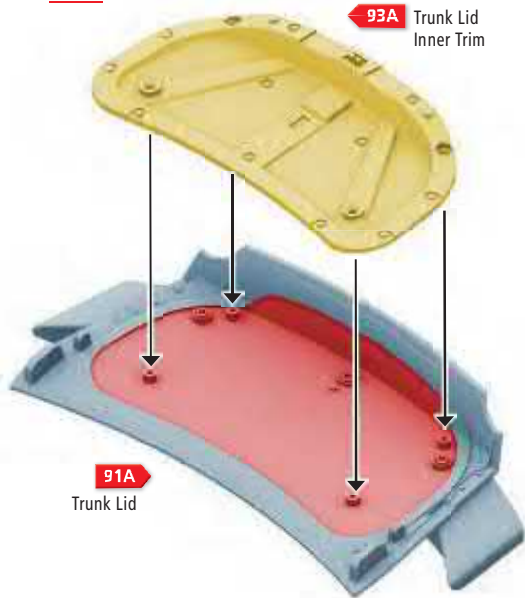

Place the Trunk Lid Inner Trim [93A] onto the reverse side of the Trunk Lid [91A], as shown in FIG.1 (left). Next, secure it in place with four TYPE GM screws, as shown in FIG.2 (below).

FIG. 2

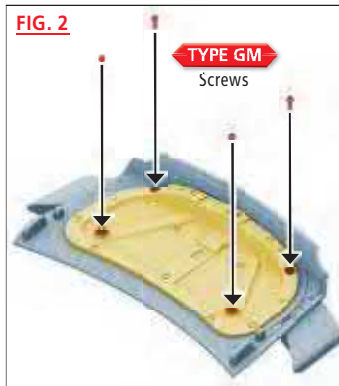

#### STEP 01 COMPLETE



## Complete!

### The Trunk Lid Inner Trim

This is how the Trunk Lid Inner Trim should look once it has been attached to the Trunk Lid.



# THE RIGHT TRUNK HINGE

Now you will attach the Right Trunk Hinge parts to your model's Trunk Lid.



**PARTS LOCATION**

## PARTS LIST



94A



94B



94C



94D



94E



94F

## PART IDENTIFICATION LIST

PART No.	NAME	QUANTITY	MATERIAL
94A	Right Lower Absorber	1	Copper Tube
94B	Right Upper Absorber	1	Copper Tube
94C	Right Lower Absorber Base	1	Zinc
94D	Right Assembly Base	1	Zinc
94E	Right Hinge A	1	Fe
94F	Right Hinge B	1	Fe
Screws	Type AM 0.10 x 0.16" [2.6 x 4mm]	2 [+1 spare]	Metal
Screws	Type BM 0.06 x 0.12" [1.5 x 3mm]	1 [+1 spare]	Metal
Screws	Type GM 0.08 x 0.16" [2 x 4mm]	1 [+1 spare]	Metal
Screws	Type IM 0.07 x 0.12" [1.7 x 3mm]	5 [+2 spare]	Metal



TYPE AM



TYPE BM



TYPE GM



TYPE IM

## STEP 01 Attach Right Hinges A and B

Place Right Hinge A [94E] and Right Hinge B [94F] on the Right Assembly Base [94D], as shown in FIG. 1.

Next, secure the Hinges in place with TYPE IM screws, as shown in FIG. 2 (far right).

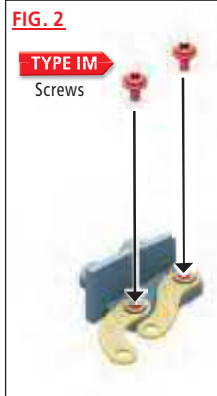
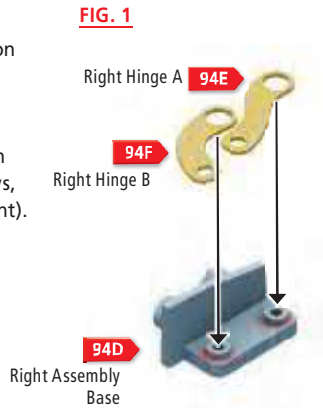

**COLOR KEY**  
■ PART BEING FITTED  
■ PART BEING FITTED TO  
■ FIXINGS



## STEP 02 Attach the Right Upper Absorber to the Trunk Lid

FIG. 1



Place the Right Upper Absorber [94B] against the hole (highlighted in red) on the reverse side of the Trunk Lid [91A], as shown in FIG. 1 (above).

Secure the Right Upper Absorber [94B] in place with a TYPE IM screw, as shown in FIG. 2 (below).

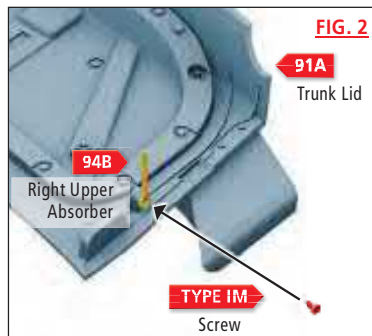

## STEP 03 Attach the Right Assembly Base and Hinges to the Trunk Lid

FIG. 1



Take the Right Assembly Base [94D] that you completed in Step 01 and position it so that the attached Hinges line up with the holes on the Trunk Lid [91A], as shown in FIG. 1 (left).

Secure the hinges to the Trunk Lid [91A] with two TYPE IM screws, as shown in FIG. 2 (right).

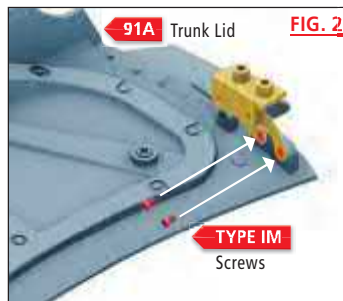

## STEP 04

### Attach the Right Lower Absorber to the Right Lower Absorber Base

Place the Right Lower Absorber [94A] against the Right Lower Absorber Base [94C] in the position highlighted in red in FIG.1 (right).

FIG. 1

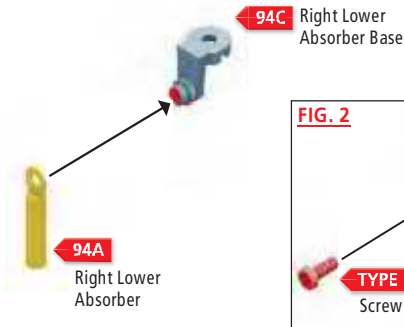

Next, secure it in place with a TYPE BM screw, as shown in FIG.2 (far right).

FIG. 2

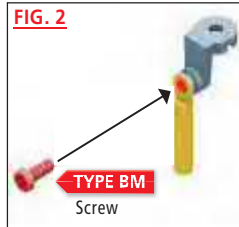

## STEP 05

### Attach the Right Lower Absorber Base to the Rear Body



Place the combined parts from Step 04 onto the area of the Rear Body [64A] highlighted in red in FIG.1 (left). Next, secure the parts in place with a TYPE GM screw, as shown in FIG.2 (below).



## Complete!

### The Right Trunk Hinge

This is how the completed Right Trunk Hinge should look once you have assembled these parts.





## THE LEFT TRUNK HINGE

In this magazine, you will attach the Left Trunk Hinge parts to your NISSAN GT-R (R35) model's Trunk Lid.

PARTS LOCATION



### PARTS LIST



95A



95B



95C



95D



95E



95F

### PART IDENTIFICATION LIST

PART No.	NAME	QUANTITY	MATERIAL
95A	Left Lower Absorber	1	Copper Tube
95B	Left Upper Absorber	1	Copper Tube
95C	Left Lower Absorber Base	1	Zinc
95D	Left Assembly Base	1	Zinc
95E	Left Hinge A	1	Fe
95F	Left Hinge B	1	Fe
Screws	Type AM 0.1 x 0.16" [2.6 x 4mm]	2 [+1 spare]	Metal
Screws	Type BM 0.06 x 0.12" [1.5 x 3mm]	1 [+1 spare]	Metal
Screws	Type GM 0.08 x 0.16" [2 x 4mm]	1 [+1 spare]	Metal
Screws	Type IM 0.07 x 0.12" [1.7 x 3mm]	5 [+2 spare]	Metal



TYPE AM



TYPE BM



TYPE GM



TYPE IM

## STEP 01

### Attach Left Hinges A and B

Place Left Hinge A [95E] and Left Hinge B [95F] on the Left Assembly Base [95D], as shown in FIG.1.

Next, secure them in place with two TYPE IM screws, as shown in FIG.2 (far right).

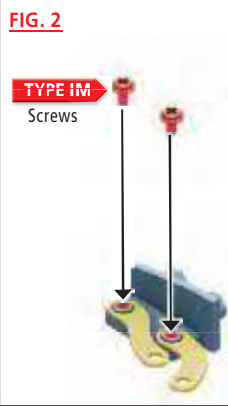
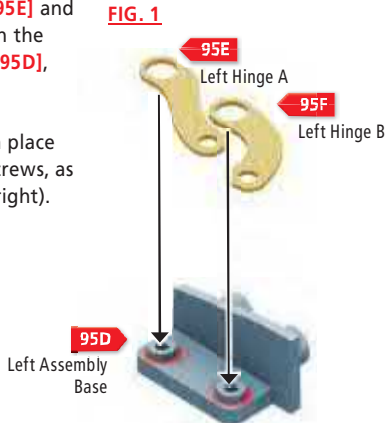

#### COLOR KEY

- PART BEING FITTED
- PART BEING FITTED TO
- FIXINGS



## STEP 02

### Attach the Left Upper Absorber to the Trunk Lid

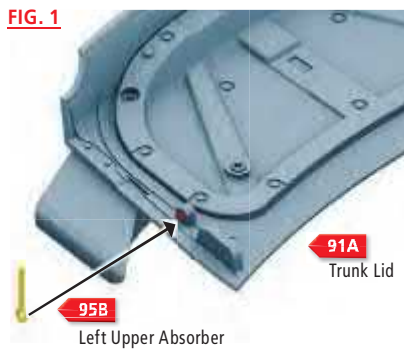

Place the Left Upper Absorber [95B] against the hole (highlighted in red) on the reverse side of the Trunk Lid [91A], as shown in FIG.1 (above).

Secure the Left Upper Absorber [95B] in place with a TYPE IM screw, as shown in FIG.2 (below).

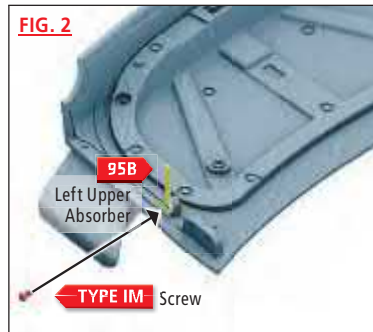

## STEP 03

### Attach the Left Assembly Base and Hinges to the Trunk Lid

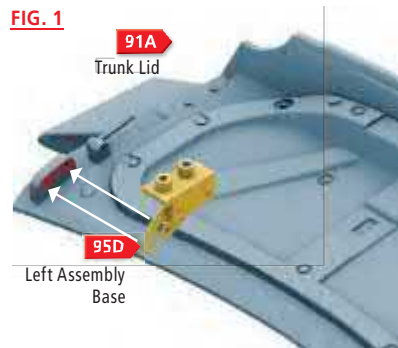

Take the Left Assembly Base [95D] that you completed in Step 01 and position it so that the attached hinges line up with the holes on the Trunk Lid [91A], as shown in FIG.1 (left).

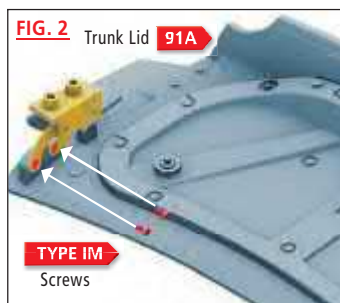

Secure the hinges to the Trunk Lid [91A] with two TYPE IM screws, as shown in FIG.2 (right).



## STEP 04 Attach the Left Lower Absorber to the Left Lower Absorber Base

Place the Left Lower Absorber [95A] against the Left Lower Absorber Base [95C] in the position highlighted in red in FIG.1 (right).

Next, secure it in place with a TYPE BM screw, as shown in FIG.2 (far right).

FIG. 1

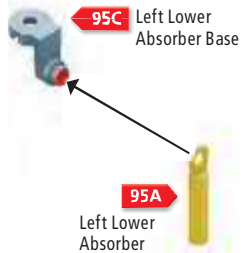
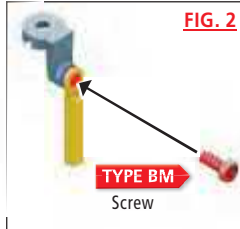

FIG. 2



## STEP 05 Attach the Left Lower Absorber Base to the Rear Body

FIG.1

FROM STEP 04  
Combined Parts



Place the parts you have just combined in Step 04 onto the area of the Rear Body [64A] highlighted in red in FIG.1 (left). Next, secure the parts in place with a TYPE GM screw, as shown in FIG.2 (below).

FIG. 2



STEP 05 COMPLETE



## STEP 06 Attach the combined Trunk parts to the Rear Body

Maneuver the combined Trunk parts – which you assembled in Magazine 24 – into the area of the Rear Body [64A] highlighted in red in FIG.1 (right).

Ensure that the Upper Absorbers slide inside the Lower Absorbers – see FIG.2 (far right).

FIG.1

FROM MAGAZINE 24  
Combined Trunk parts

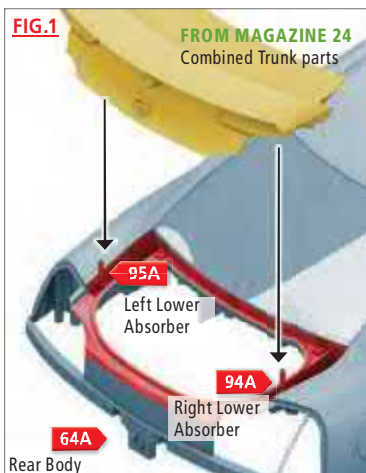

When attaching the Trunk parts, both the Left and Right Upper Absorbers have to slide into the two Lower Absorbers. FIG.2 (right) illustrates how the Right Upper Absorber [94B] should slide inside the Right Lower Absorber [94A].

FIG. 2

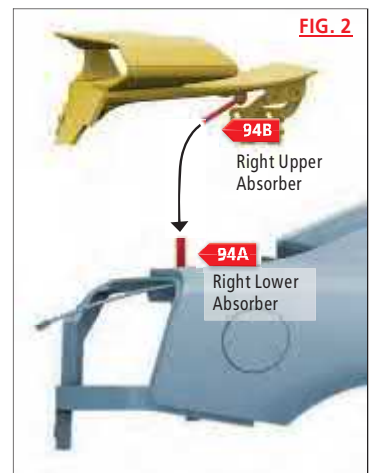

Once the Upper Absorbers are inside the Lower Absorbers, maneuver the Right Assembly Base [94D] and the Left Assembly Base [95D] into the spaces on either side of the Trunk opening. The struts on the bottom of the Assembly Bases should fit inside the corresponding holes on the Rear Body.



## STEP 07

Secure the combined Trunk parts to the Rear Body

Secure the Right Assembly Base [94D] and the Left Assembly Base [95D] from the underside of the Rear Body [64A] with four TYPE AM screws, as shown in the illustration.

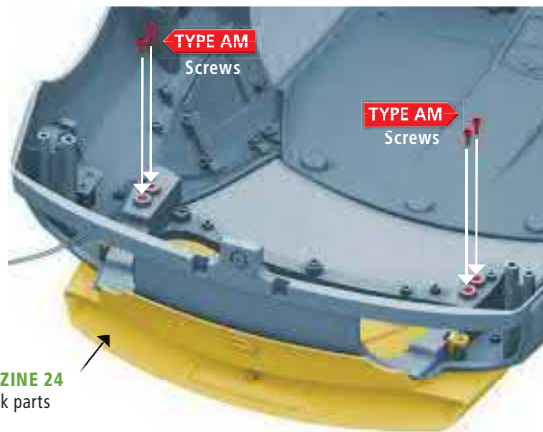

## Complete!

The Trunk Lid is attached

This is how your NISSAN GT-R (R35) model should look once you have attached the Trunk Lid parts to the Car Body.



## THE REAR BUMPER

Now you will attach several of the parts you received with Magazine 05 to the Rear Bumper of your model.

**PARTS LOCATION**



### PARTS LIST



TYPE HM



TYPE MP

### PART IDENTIFICATION LIST

PART No.	NAME	QUANTITY	MATERIAL
96A	Rear Bumper	1	Zinc
Screws	Type HM 0.09 x 0.16" [2.3 x 4mm]	7 [+3 spare]	Metal
Screws	Type MP 0.07 x 0.16" [1.7 x 4mm]	2 [+1 spare]	Metal



## STEP 01

### Attach the Rear Diffuser Middle Vent

FIG. 1

96A  
Rear Bumper

Push the Rear Diffuser Middle Vent [18C], which you received with Magazine 05, onto the reverse side of the Rear Bumper [96A], as shown in FIG.1 (left).

Next, use three TYPE HM screws in the top three holes and two TYPE MP screws in the bottom two holes to secure it in position, as shown in FIG.2 (below).

#### COLOR KEY

- PART BEING FITTED
- PART BEING FITTED TO
- FIXINGS

18C  
Rear Diffuser Middle Vent

TYPE HM  
Screws

TYPE HM  
Screws

TYPE HM  
Screws

FIG. 2

#### STEP 01 COMPLETE



## STEP 02

### Attach the Left Rear Exhaust Trim

FIG. 1

96A  
Rear Bumper

Push the Left Rear Exhaust Trim [18E] (which also came with Magazine 05) into the area highlighted in red on the Rear Bumper [96A], as illustrated in FIG.1 (left). Next, secure it in place with two TYPE HM screws, as shown in FIG.2 (below).

18E  
Left Rear Exhaust Trim

FIG. 2

TYPE HM  
Screws

#### STEP 02 COMPLETE



## STEP 03 Attach the Right Rear Exhaust Trim

FIG. 1

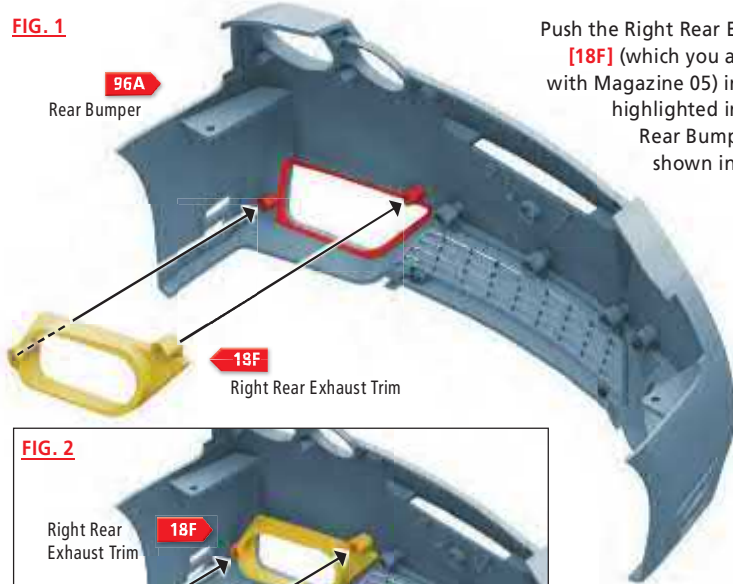

Push the Right Rear Exhaust Trim [18F] (which you also received with Magazine 05) into the area highlighted in red on the Rear Bumper [96A], as shown in FIG.1 (left).

### STEP 03 COMPLETE



FIG. 2

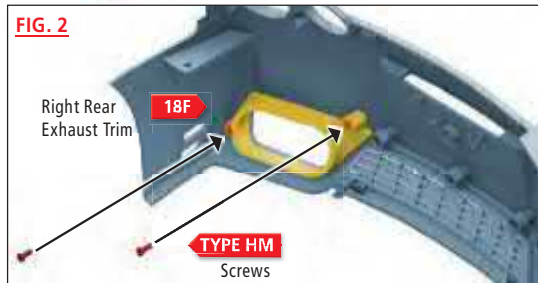

Now secure the Right Rear Exhaust Trim [18F] in place with two TYPE HM screws, as shown in FIG.2 (left).

## Complete!

### The Rear Bumper parts

This is how the Rear Bumper should look at this stage, once you have completed these instructions.



# THE REAR BUMPER

Let's add the parts you received with this magazine to the Rear Bumper of your NISSAN GT-R (R35).

**PARTS LOCATION**



## PARTS LIST



97A



97B



97C



97D



TYPE BP



TYPE GM

## PART IDENTIFICATION LIST

PART No.	NAME	QUANTITY	MATERIAL
97A	Rear GT-R Badge	1	ABS
97B	License Plate Light	1	GP
97C	Left Turn Signal	1	GP
97D	Right Turn Signal	1	GP
Screws	Type BP 0.06 x 0.12" [1.5 x 3mm]	1 [+1 spare]	Metal
Screws	Type GM 0.08 x 0.16" [2 x 4mm]	4 [+3 spare]	Metal



## STEP 01 Attach the Left Turn Signal

Place the Left Turn Signal [97C] into the area highlighted in red on the Rear Bumper [96A], as shown in FIG.1 (right).

Now secure it in place with a TYPE GM screw, as shown in FIG.2 (far right).

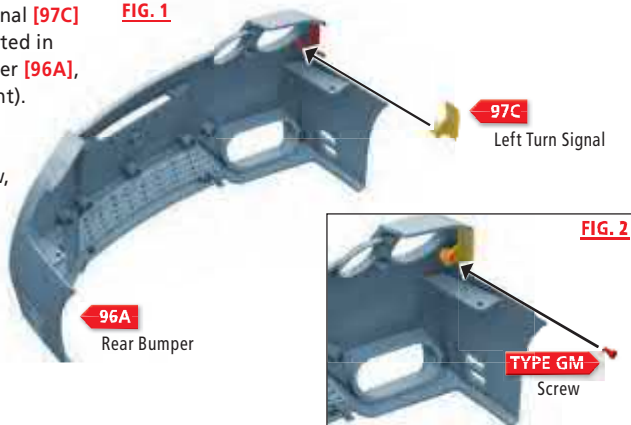

### COLOR KEY

- PART BEING FITTED
- PART BEING FITTED TO
- FIXINGS



## STEP 02 Attach the Right Turn Signal

Place the Right Turn Signal [97D] into the area highlighted in red on the Rear Bumper [96A], as shown in FIG.1 (right). Secure it in place with a TYPE GM screw, as shown in FIG.2 (below right).

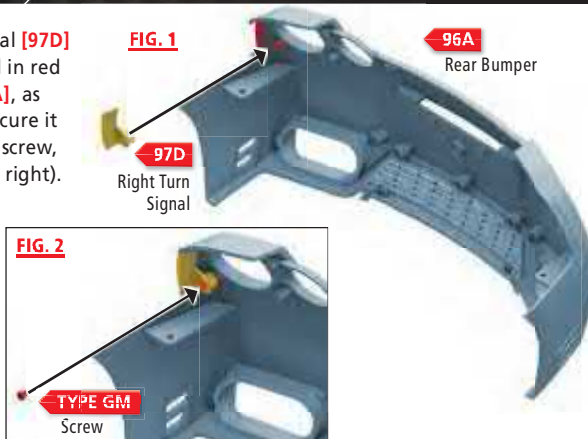

## STEP 03 Attach the License Plate Light

FIG.1

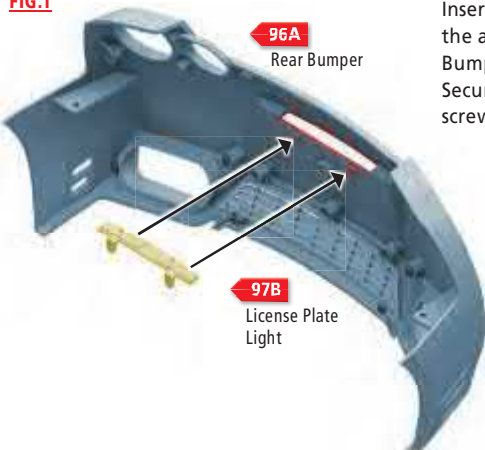

Insert the License Plate Light [97B] into the area highlighted in red on the Rear Bumper [96A], as indicated in FIG.1 (left). Secure it in place with two TYPE GM screws, as shown in FIG.2 (below).

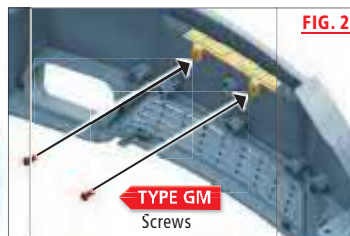

## STEP 04

### Attach the Rear GT-R Badge

Push the strut on the reverse of the Rear GT-R Badge [97A] into the hole highlighted in red on the Rear Bumper [96A] in the illustration (right).

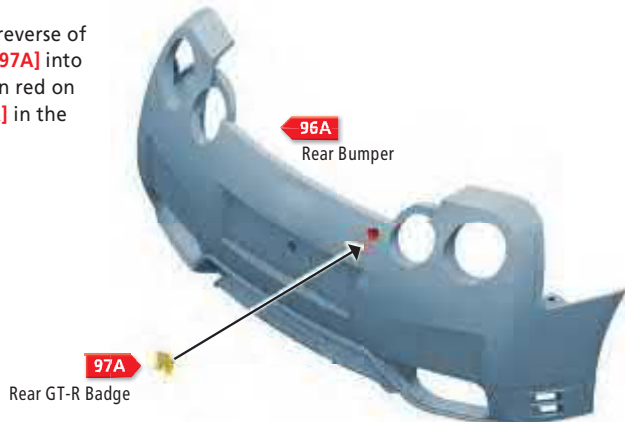

## STEP 05

### Secure the Rear GT-R Badge

Holding the Rear GT-R Badge [97A] firmly in place, secure it from the inside of the Rear Bumper [96A] using a TYPE BP screw, as shown in the illustration.

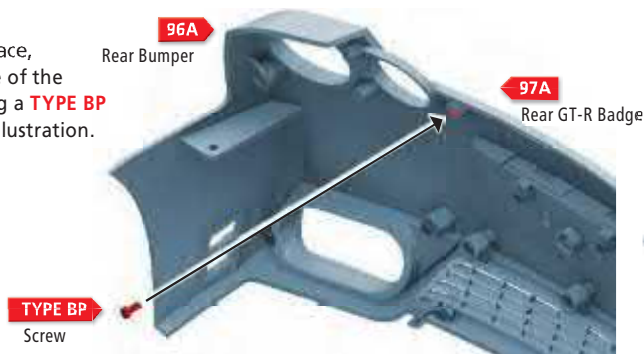

## Complete!

### The Rear Bumper parts

This is how your model's Rear Bumper should look once you have completed these steps.



## THE REAR LIGHTS

Now you will assemble the Rear Lights and combine your model's upper Car Body with its lower Chassis.

### PARTS LOCATION



### PARTS LIST

#### PART IDENTIFICATION LIST

PART No.	NAME	QUANTITY	MATERIAL
98A	Left Light Base	1	ABS
98B	Right Light Base	1	ABS
98C	Left Light Lens	1	GP
98D	Right Light Lens	1	GP
98E	Front Support Blocks	2	ABS
Screws	Type AM 0.1 x 0.16" [2.6 x 4mm]	7 [+4 spare]	Metal
Screws	Type HM 0.09 x 0.16" [2.3 x 4mm]	4 [+2 spare]	Metal
Screws	Type RM 0.1 x 0.2" [2.6 x 6mm]	12 [+8 spare]	Metal

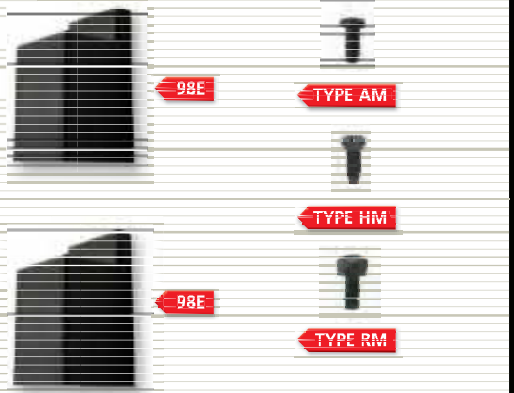

## STEP 01

### Assemble the Rear Lights

Place the Right Light Lens [98D] onto the Right Light Base [98B], as shown in FIG.1 (right).

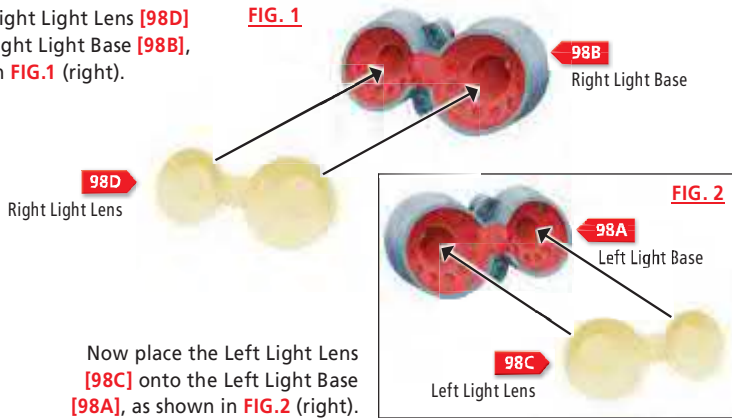

Now place the Left Light Lens [98C] onto the Left Light Base [98A], as shown in FIG.2 (right).

#### COLOR KEY

- PART BEING FITTED
- PART BEING FITTED TO
- FIXINGS

#### STEP 01 COMPLETE



## STEP 02

### Attach the combined Right Rear Lights

**FIG. 1**



Insert the combined Right Rear Lights into the space on the Rear Bumper [96A] shown in FIG.1 (left).

Secure them in place with two TYPE HM screws, as shown in FIG.2 (below).

**FIG. 2**

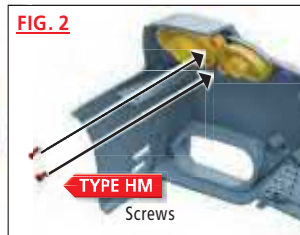

#### STEP 02 COMPLETE



## STEP 03

### Attach the combined Left Rear Lights

**FIG. 1**

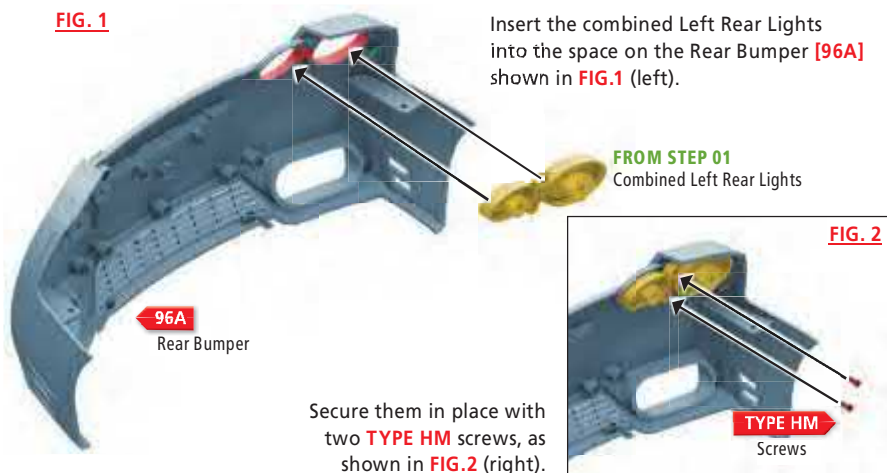

Insert the combined Left Rear Lights into the space on the Rear Bumper [96A] shown in FIG.1 (left).

Secure them in place with two TYPE HM screws, as shown in FIG.2 (right).

**FIG. 2**

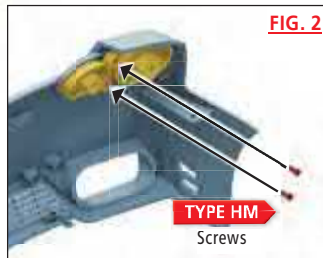

#### STEP 03 COMPLETE



## STEP 04 Attach the Front Fascia

FIG. 1

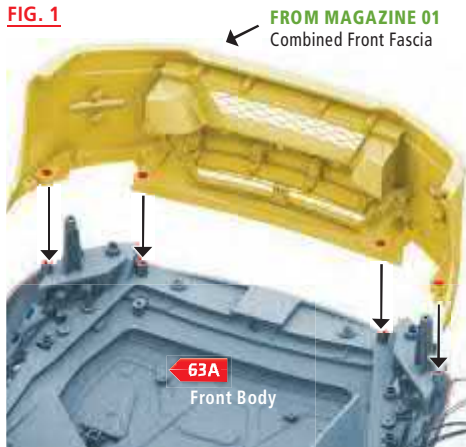

Take the Front Fascia that you assembled in Magazine 01 and place it on the Front Body [63A], as shown in FIG.1 (left).

Now secure the parts together with four TYPE AM screws, as shown in FIG.2 (below).

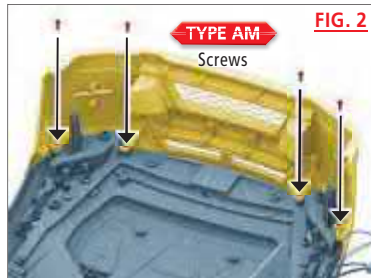

## STEP 05 Connect the Interior Light Switch and Headlight wires

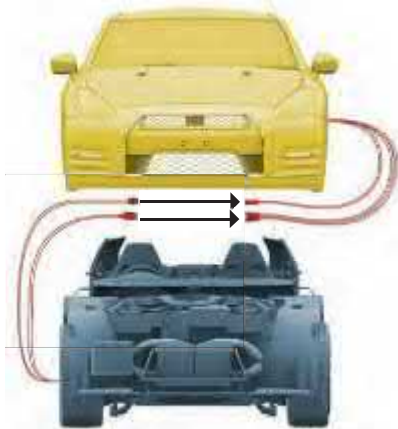

Insert the two-hole connector belonging to the Interior Light Switch [61B] (that came with Magazine 16) – which is attached to the upper Car Body – into the two-prong connector that is protruding from the lower Chassis.

Next, Insert the four-prong connector belonging to the Headlights [61C] (also from Magazine 16) – which is attached to the upper Car Body – into the four-hole connector that is protruding from the lower Chassis.



## STEP 06 Connect the Interior Light wires



Insert the two-hole connector belonging to the Interior Light [61D] (that came with Magazine 16) – which protrudes from the back of the upper Rear Body – into the two-prong connector that protrudes from the rear of the lower Chassis.



## STEP 07 Attach the upper Car Body to the lower Chassis

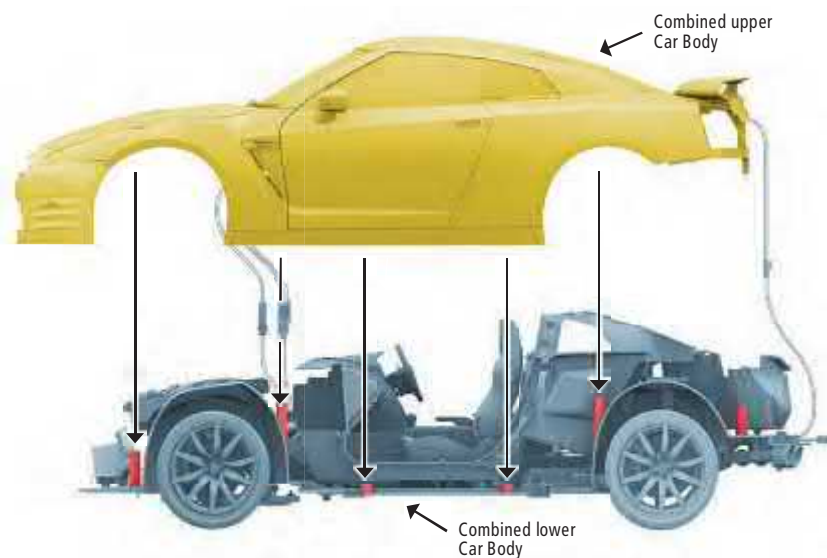

Take the entire combined upper Car Body and carefully place it onto the combined lower Chassis. Maneuver the upper Car Body so that it is tightly pressed against the lower Chassis. Ensure that all the wires are concealed, **apart from** the wire that will connect to the Brake Lights.

STEP 07 COMPLETE



## STEP 08 Secure the upper Car Body to the lower Chassis

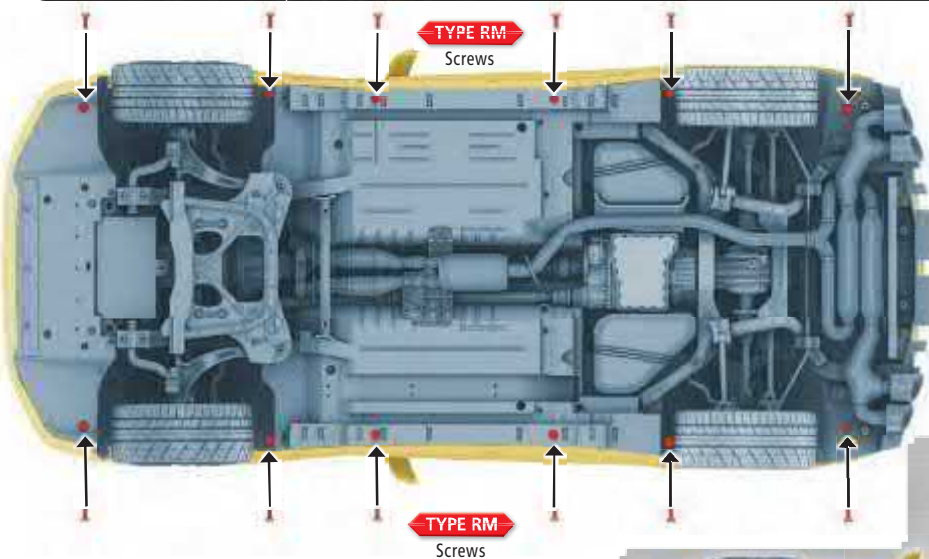

STEP 08 COMPLETE

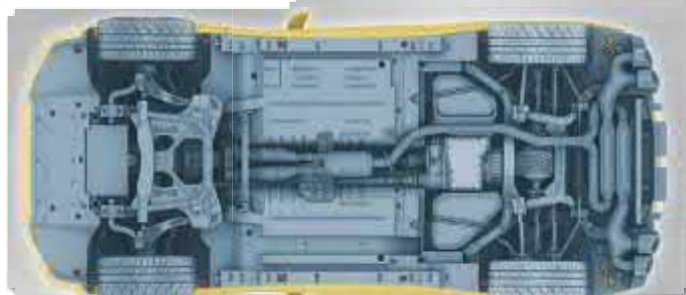

When you are satisfied that the upper Car Body is tightly pressed against the lower Chassis – and that all the screw holes line up – use 12 **TYPE RM** screws in the holes indicated in the illustration (above) to secure the two halves of your model together.

## Front Support Blocks

Place the Front Support Blocks [98E] under the Front Bumper, so that the Front Wheels are lifted off the floor. It does not matter where you place the Front Support Blocks, so long as they raise the Front Wheels.

The purpose of the blocks is to allow the Front Wheels to be turned by the Steering Wheel without damaging the Steering Mechanism.

**98E**  
Front Support Blocks



## Complete!

### The Car Body & Chassis

The inset photo shows how the Rear Lights should look once they have been attached.



The main picture shows how the model should look once you have completed these instructions.





# HOW TO BUILD

## THE REAR OF THE CAR

In this magazine, you will attach the Brake Lights, Rear License Plate, Rear Bumper and the Diffuser Panels to your model.

### PARTS LOCATION



### PARTS LIST



99A

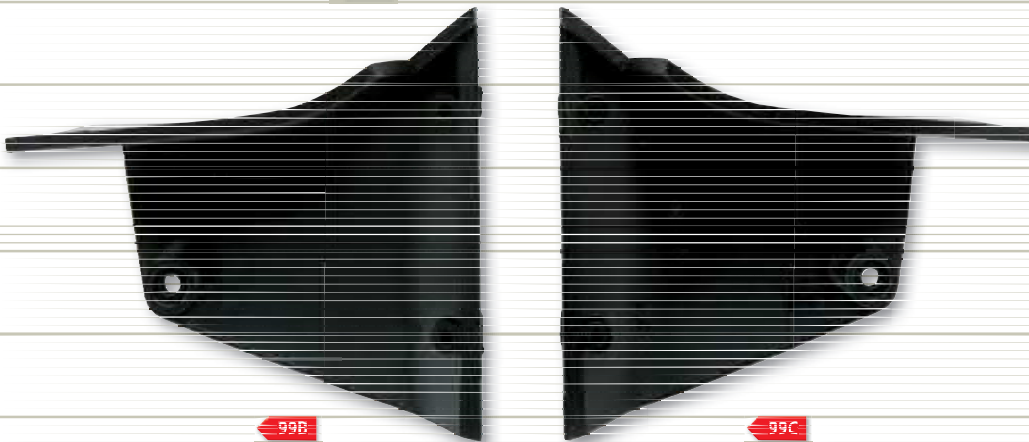

99B

99C



TYPE AM



TYPE HP

### PART IDENTIFICATION LIST

PART No.	NAME	QUANTITY	MATERIAL
99A	Rear License Plate	1	Zinc
99B	Left Side Diffuser	1	ABS
99C	Right Side Diffuser	1	ABS
Screws	Type AM 0.1 x 0.16" [2.6 x 4mm]	8 [+2 spare]	Metal
Screws	Type HP 0.09 x 0.16" [2.3 x 4mm]	4 [+2 spare]	Metal

## STEP 01 Attach the Brake Lights

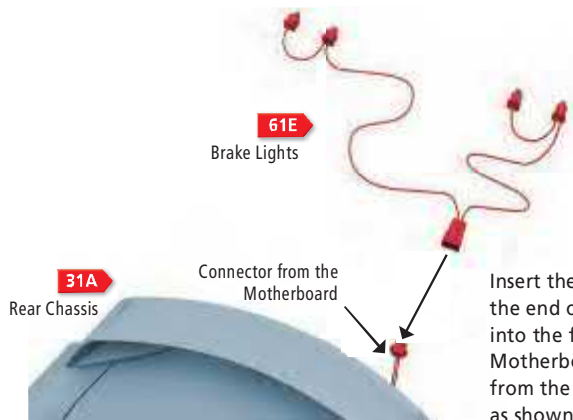

Insert the four-prong connector on the end of the Brake Lights [61E] wire into the four-hole connector from the Motherboard. This should be protruding from the back of the Rear Chassis [31E], as shown in the illustration (left).

### COLOR KEY

- PART BEING FITTED
- PART BEING FITTED TO
- FIXINGS

### STEP 01 COMPLETE



## STEP 02 Attach the Brake Light Bulbs

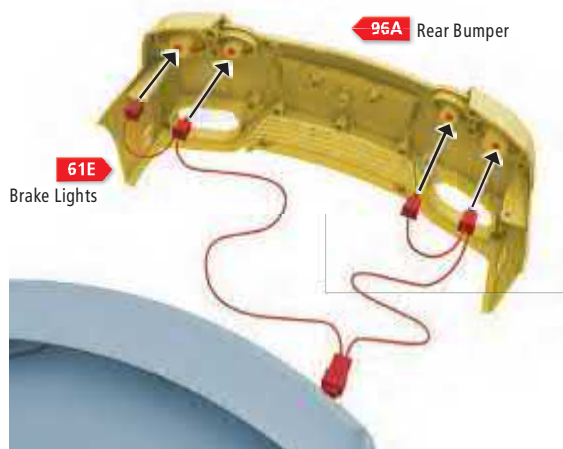

Push the bulbs on the end of the Brake Lights [61E] wire into the four holes on the inside of the Rear Bumper [96A], as indicated in the illustration (left). The bulbs may appear too large for the holes, but they will go in if pushed firmly.

### STEP 02 COMPLETE



## STEP 03 Attach the Rear Bumper

FIG. 1



Push the Rear Bumper [96A] onto the Rear Body [64A], ensuring that you tuck the Brake Lights [61E] wire out of the way. Secure it with a TYPE AM screw in the hole indicated in FIG.2 (below).

FIG. 2

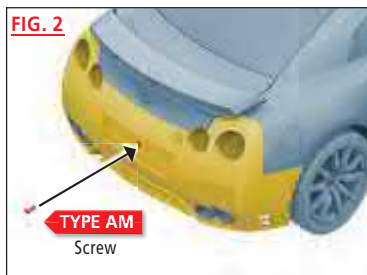

### STEP 03 COMPLETE



## STEP 04 Secure the Rear Bumper

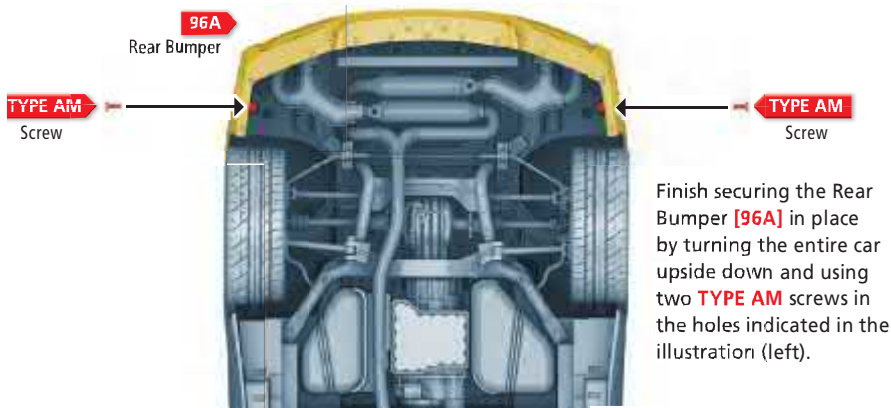

## STEP 05 Attach the Rear License Plate

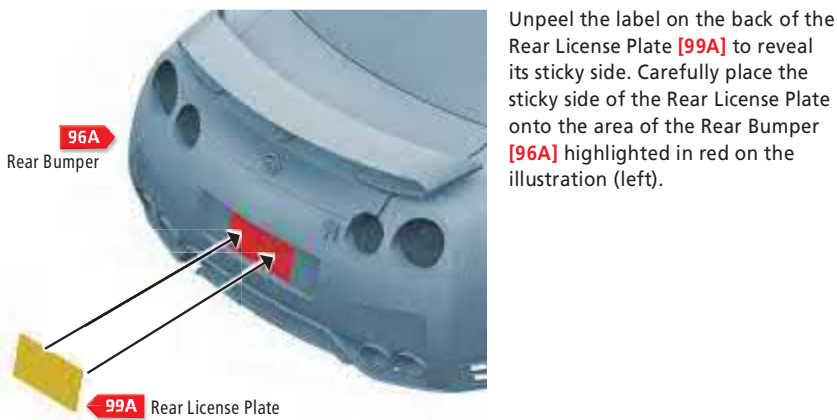

## STEP 06 Attach the Left and Right Side Diffusers to the Rear Diffuser Panel

Place the Left Side Diffuser [99B] and Right Side Diffuser [99C] onto the Rear Diffuser Panel [18A] so that the screw holes line up, as shown in FIG. 1 (below).

From the opposite side of the Rear Diffuser Panel [18A], use four TYPE HP screws in the holes to secure the parts in place, as indicated in FIG. 2 (below).

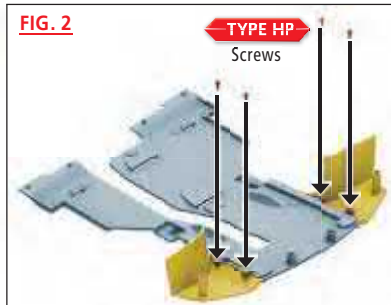
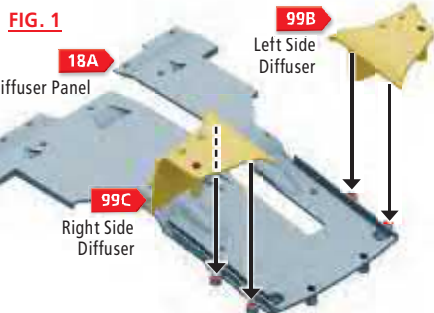

## STEP 07 Attach the Rear Diffuser Panel

Turn the entire car upside down and position the Rear Diffuser Panel [18A] onto the underside of the Rear Chassis [31A], as shown in FIG.1 (right), so that all the screw holes line up.

FIG. 1

18A  
Rear Diffuser Panel

31A  
Rear Chassis

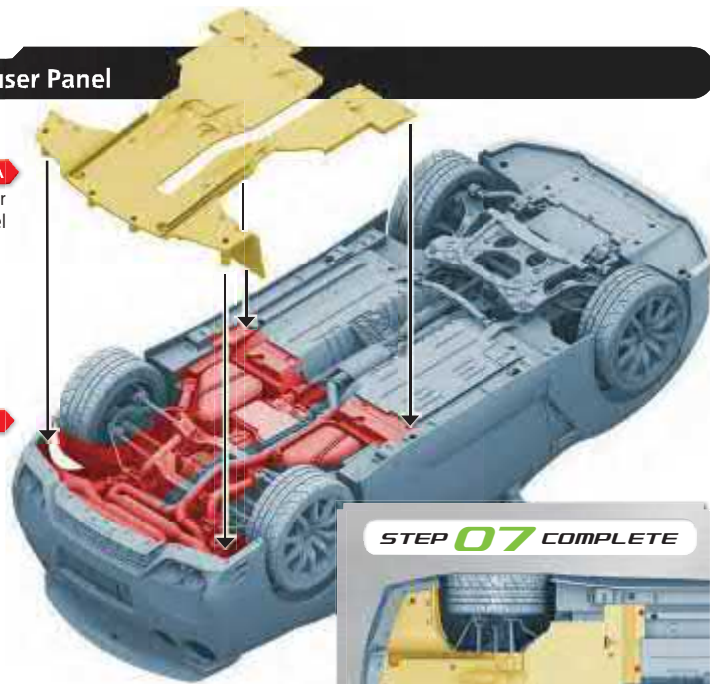
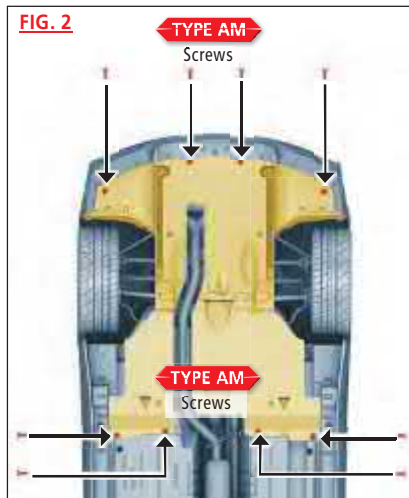

FIG. 2



Next, use eight **TYPE AM** screws in the holes indicated in FIG.2 (above) to secure the Rear Diffuser Panel in place.

## Complete!

### The License Plate and Diffuser Panel

These two photographs show how your model should look once you have completed the steps in this section.



Rear View

### Underside View



## THE CARPETS

Finally, you will complete your NISSAN GT-R (R35) model build by fitting the Carpets.

### PARTS LOCATION

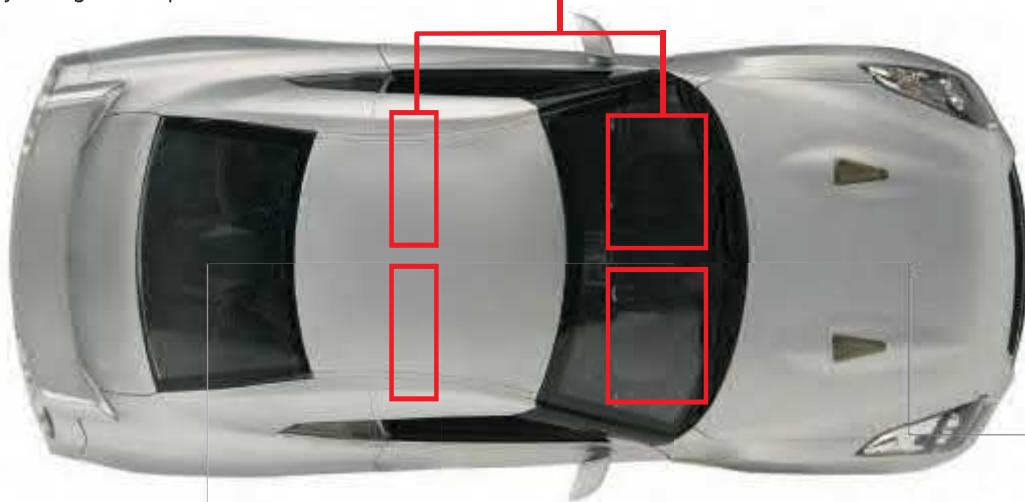

### PARTS LIST

#### PART IDENTIFICATION LIST

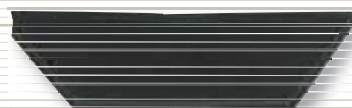
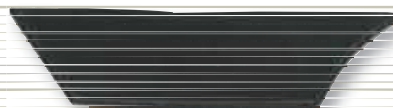

PART No.	NAME	QUANTITY	MATERIAL
100A	Front Left Carpet	1	TPR
100B	Front Right Carpet	1	TPR
100C	Rear Left Carpet	1	TPR
100D	Rear Right Carpet	1	TPR



## STEP 01

### Fit the Front Right Carpet

#### COLOR KEY

-  PART BEING FITTED
-  PART BEING FITTED TO
-  FIXINGS

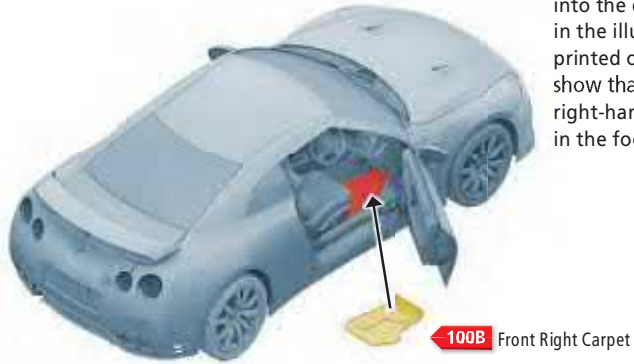

Place the Front Right Carpet **[100B]** into the driver's footwell, as shown in the illustration. The letter 'R' is printed on the back of the carpet to show that it should be fitted on the right-hand side. You simply place it in the footwell.



## STEP 02

### Attach the Front Left Carpet



Place the Front Left Carpet **[100A]** into the driver's footwell, as shown in the illustration. The letter 'L' is printed on the back of the carpet to show that it should be fitted on the left-hand side. You simply place it in the footwell.



## STEP 03

### Fit the Rear Left and Right Carpets

**FIG. 1**

Place the Rear Right Carpet **[100D]** behind the driver's seat, as shown in **FIG. 1**. It has 'R' printed on the back of it. Finally, place the Rear Left Carpet **[100C]** behind the passenger seat, as shown in **FIG. 2**.



**FIG. 2**



## Complete!

### Your NISSAN GT-R (R35) model

After 26 magazines and more than 500 individual parts, your high-quality scale model of the legendary NISSAN GT-R (R35) is now ready to be displayed. We hope that you have enjoyed building your model and found it a satisfying, informative and rewarding experience.



Your model is made from high-quality materials and weighs over 22 lbs (10 kg).



The steering wheel in the highly-detailed car interior can turn the front wheels.



The model has many movable parts, including opening trunk, doors and hood.



**TIP!**

Remember to place the car on the two blocks that came with magazine 25 before you turn the steering wheel.



The opening doors feature windows that you can manually wind up and down.



The hood can be propped open to display the accurate VR38DETT engine.



The model features working brake lights, as well as headlights and interior lights.



# Kit details

**Your Nissan GT-R full kit is broken down as follows:**

<b>PACK 1</b>	<b>#11, #15, #21, #38, #49, #57, #75, #68-69, #80, #83, #93</b>
<b>PACK 2</b>	<b>#5, #16, #19, #35, #37, #39, #66, #70, #72-74, #77, #82, #89, #91</b>
<b>PACK 3</b>	<b>#2, #4, #13, #26, #78, #84</b>
<b>PACK 4</b>	<b>#6-8, #12, #43, #48, #87, #94</b>
<b>PACK 5</b>	<b>#9-10, #17-18, #27, #44, #56, #75, #81, #92</b>
<b>PACK 6</b>	<b>#20, #24-25, #40, #51, #79</b>
<b>PACK 7</b>	<b>#22-23, #29, #34, #36, #41, #45, #50, #62, #85, #90, #97-99</b>
<b>PACK 8</b>	<b>#1, #3, #71, #86</b>
<b>PACK 9</b>	<b>#64</b>
<b>PACK 10</b>	<b>#14, #28, #30, #58-61, #67, #76, #96, #100</b>
<b>PACK 11</b>	<b>#31-33, #53-54</b>
<b>PACK 12</b>	<b>#41, #46-47, #52, #55, #63, #88, #95</b>



# BUILD THE

# NISSAN GT-R

## Guide to the instructions

This set of step-by-step instructions will enable you to complete the build of your **1:8-scale Nissan GT-R**. The only tool you will need is a screwdriver. Most of the steps involve simply screwing or fitting parts together, and the correct screws needed for each step are clearly labelled on the instructional images.

### Please note the following:

- Where left and right elements of the same part are supplied, these are listed as (left) and (right).
- You will not be using every part you receive in your shipment in that build section. Keep any parts that are not used aside for use in a later sequence.
- You will receive extra screws with each shipment in case any screws are lost or broken.
- Screws with codes ending in the letter M drive into metal; those ending in the letter P drive into plastic.
- With M screws, first drive the screw in half-way. Then unscrew it to release the shavings created as the screw cuts its thread. Finally, drive the screw fully into the socket. M screws should be tightened so the head makes firm contact with the fixing surface.
- With P screws, do not over-tighten them as they can damage the socket.
- When working with the pre-finished exterior surfaces of the model, work on a soft cloth. This will protect against scratching the paintwork.
- When plugging wires in, ensure the power is switched off.
- Tweezers can be used to fit the PVC cables. In this case, grip carefully around 5mm from the end of the cable. If the end of the cable is too narrow to fit on to the pin, cautiously insert a cocktail stick, being wary not to split the cable.
- Some smaller plastic parts are attached to sprues. You can remove these by hand, or by careful use of a cutting implement such as a scalpel.



**NISSAN**  
MOTOR CORPORATION

OFFICIAL LICENSED PRODUCT

81-9810-61348

Nissan Motor Co., Ltd. trademarks, designs, copyrights and/or other intellectual property rights are used under license.

© IXOCOLLECTIONS SAS  
© IXOMODELS

**Customer service:** [contact@ixo-collections.fr](mailto:contact@ixo-collections.fr)  
**Packaged by:** Milanoedit srl, [www.milanoedit.com](http://www.milanoedit.com)