

3D-Funktionsmodell Scherenhublift

(EN) 3D functional model scissor lift (FR) Modèle fonctionnel 3D de l'élevateur à ciseaux (NL) 3D functioneel model schaarlift

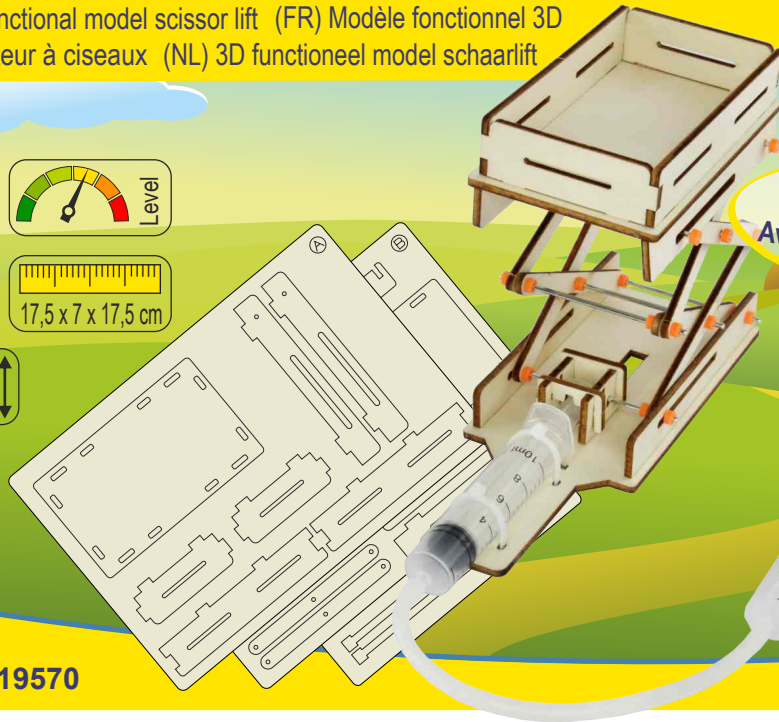
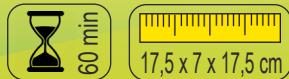

Mit pneumatischer Hebe- und Senkfunktion!
With pneumatic lifting and lowering function
Avec fonction de levage et d'abaissement pneumatique
Met pneumatische hef- en daalfunctie

WEEB 001059030555
MADE IN PRC

Art.no.: 19570



SOL-EXPERT group, C.Reply
Mehlisstrasse 19, D-88255 Baindt
Tel.: +49 (0)7502 - 94115-0
Fax: +49 (0)7502 - 94115-99
info@sol-expert-group.de
www.sol-expert-group.de

(DT) **ACHTUNG:** Nicht geeignet für Kinder unter 3 Jahren. Verschluckbare Kleinteile! (EN) **ATTENTION:** Not suitable for children under 3 years. Contains small parts!
(FR) **ATTENTION:** Ne convient pas pour les enfants de moins de trois ans contient de petites pièces pouvant être ingérées!
(NL) **ATTENTIE:** Niet geschikt voor kinderen beneden 3 jaar - kleine onderdelen kunnen worden ingeslikt!



© 2024 C. Reply

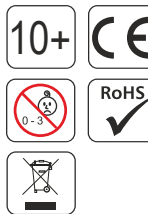

(DT) BAUANLEITUNG

Wenn du folgende Tipps beachtest, gelingt der Aufbau garantiert:

Hinweise:

- Brich das in der Montageanleitung erforderliche Bauteil erst dann aus der Holzplatte, wenn dieses Teil aktuell für den Aufbau benötigt wird. Das erleichtert später das Auffinden der einzelnen Teile erheblich.
- Entferne die benötigten Holzteile vorsichtig, mit leichtem Druck aus der Trägerplatte. Pass auf, dass du kein Teil aus Versehen zerbrichst.
- Um deinem Modell mehr Stabilität zu geben, kannst du ein klein wenig Holzkleber bei der Montage benutzen.
- Die Zahlen, die du auf den einzelnen Teilen in der Anleitung siehst, zeigen dir, welche Bauteile aktuell für die Montage benötigt werden.

Ablauf:

- Löse das Teil „1“ aus der Platte gemäß der Anleitung und lege es bereit.
- Nun Teil „2“ ausbrechen und mit Teil „1“ zusammenstecken.
- Jetzt kommt Teil „3“ usw. Haben zwei Teile die gleiche Nummer, werden beide montiert. Die farbliche Kennzeichnung hilft dir dabei, dass alle Teile am richtigen Ort montiert werden.

(EN) ASSEMBLY INSTRUCTIONS

If you follow the tips below, successful construction is guaranteed:

Notes:

- Only break the component required in the assembly instructions out of the wooden panel when this part is currently needed for the assembly. This makes it much easier to find the individual parts later.
- Carefully remove the required wooden parts from the support plate by applying light pressure. Be careful not to break any part by mistake.
- To give your model more stability, you can use a little wood glue during assembly.
- The numbers you see on each part in the instructions show you which parts are currently needed for assembly.

Procedure:

- Detach part "1" from the board according to the instructions and lay it out ready.
- Now break out part "2" and put it together with part "1".
- Now comes part "3" and so on. If two parts have the same number, both are assembled. The colour coding helps you to make sure that all parts are assembled in the right place.

(FR) INSTRUCTIONS DE CONSTRUCTION

En suivant ces conseils, tu réussiras ta construction à tous les coups :

Remarques :

- Attends qu'une pièce soit indiquée dans les instructions de montage pour la séparer du reste. Cela facilite considérablement la recherche des différentes pièces par la suite.
- Retire avec précaution les pièces en bois nécessaires de la plaque de support en exerçant une légère pression. Fais attention à ne pas casser de pièce par accident.
- Pour donner plus de stabilité à ton modèle, tu peux utiliser un peu de colle à bois lors du montage.
- Les chiffres que tu vois sur les différentes pièces dans les instructions t'indiquent quels composants sont actuellement nécessaires pour le montage.

Déroulement de la procédure :

- Détache la pièce "1" de la plaque selon les instructions et prépare-la.
- Détache maintenant la pièce "2" et assemble-la à la pièce "1".
- Puis vient la pièce "3", etc. Si deux pièces ont le même numéro, elles doivent être montées toutes les deux. Le code couleur t'aidera à monter toutes les pièces au bon endroit.

Als je de onderstaande tips opvolgt, is het resultaat gegarandeerd:

Aanwijzingen:

- Breek het in de handleiding genoemde onderdeel pas uit de houten plaat wanneer het op dat moment nodig is voor de montage. Dit maakt het veel gemakkelijker om de afzonderlijke onderdelen later terug te vinden.
- Haal de benodigde houten onderdelen voorzichtig met lichte druk uit de plaat. Pas op dat je niet per ongeluk een onderdeel breekt.
- Om je model meer stevigheid te geven, kun je tijdens de montage een beetje houtlijm gebruiken.
- De nummers die je in de handleiding op elk onderdeel ziet staan, geven aan welke onderdelen je op dat moment nodig hebt voor de montage.

Procedure:

- Maak deel '1' volgens de instructies los van de plaat en leg het klaar.
- Breek nu deel '2' af en bevestig het aan deel '1'.
- Nu komt deel "3" en zo verder. Als twee delen hetzelfde nummer hebben, worden ze allebei gemonteerd. De kleurcodering helpt je ervoor te zorgen dat alle onderdelen op de juiste plaats worden gemonteerd.

A

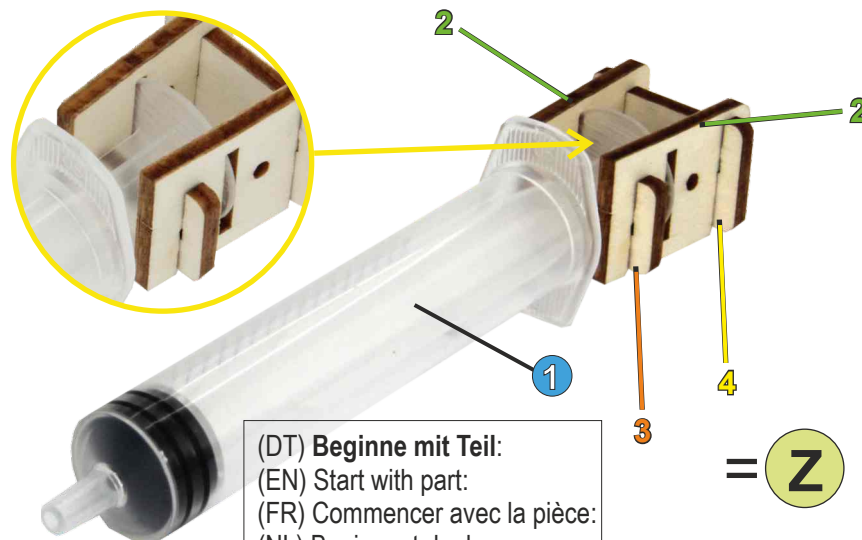
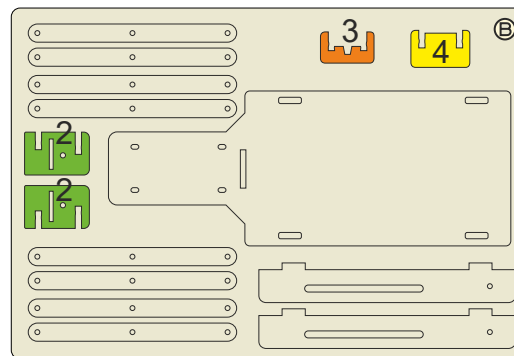

(DT) Beginne mit Teil:
(EN) Start with part:
(FR) Commencer avec la pièce:
(NL) Begin met deel :

1 → 2 → 3 → 4

= Z

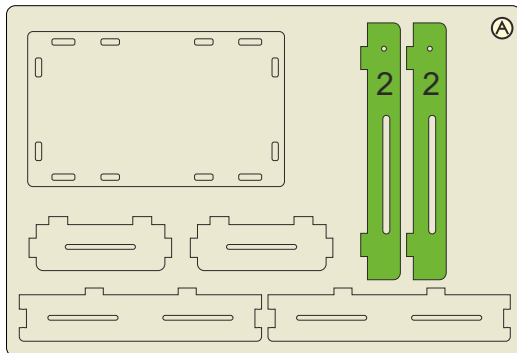
B

Ⓐ

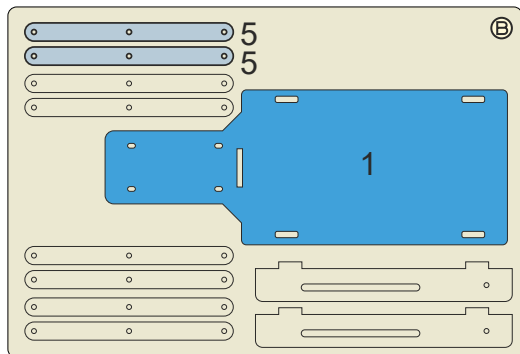
6 x  41 x  3

Ⓑ

(DT) Beginne mit Teil:**(EN) Start with part:****(FR) Commencer avec la pièce:****(NL) Begin met deel :**

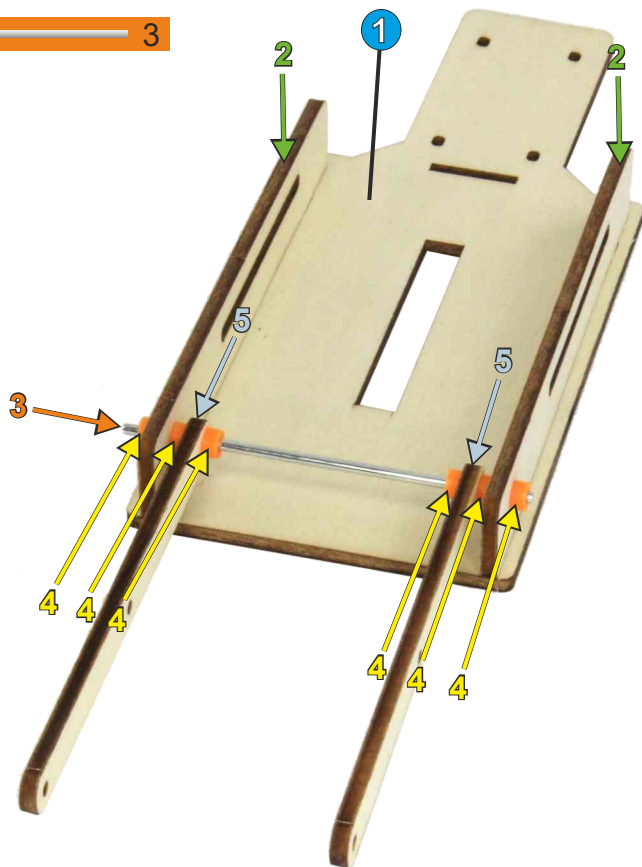

C

Ⓢ

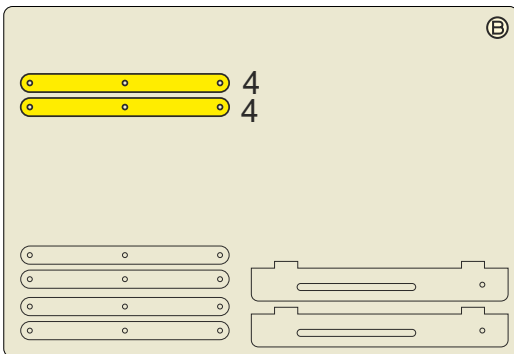
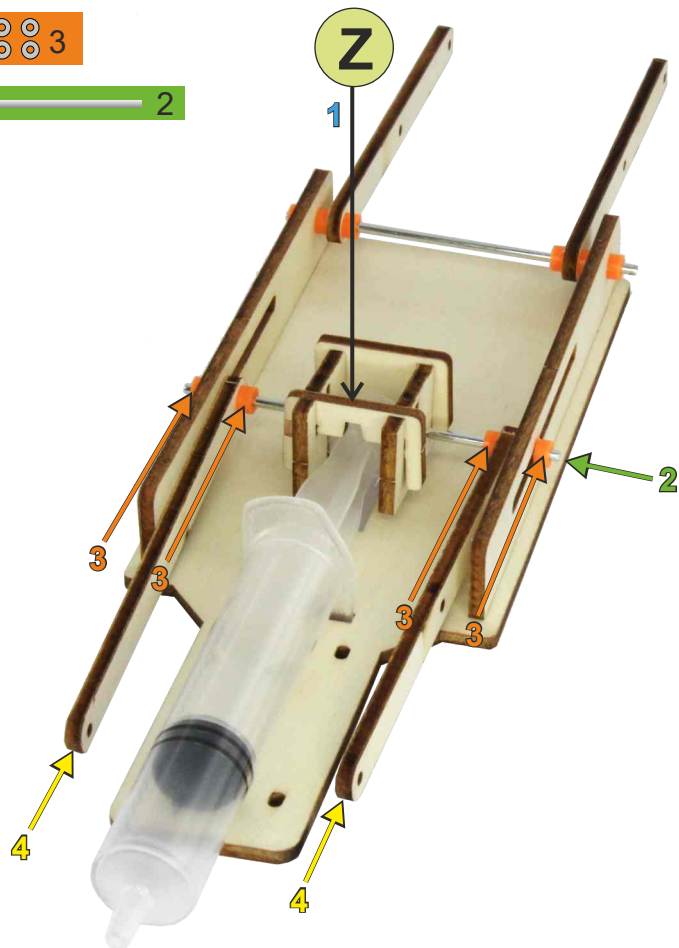
4 x  31 x  2**(DT) Beginne mit Teil:****(EN) Start with part:****(FR) Commencer avec la pièce:****(NL) Begin met deel :****Z** → **2** → **3** → **4**

D

4 x 

1 x 

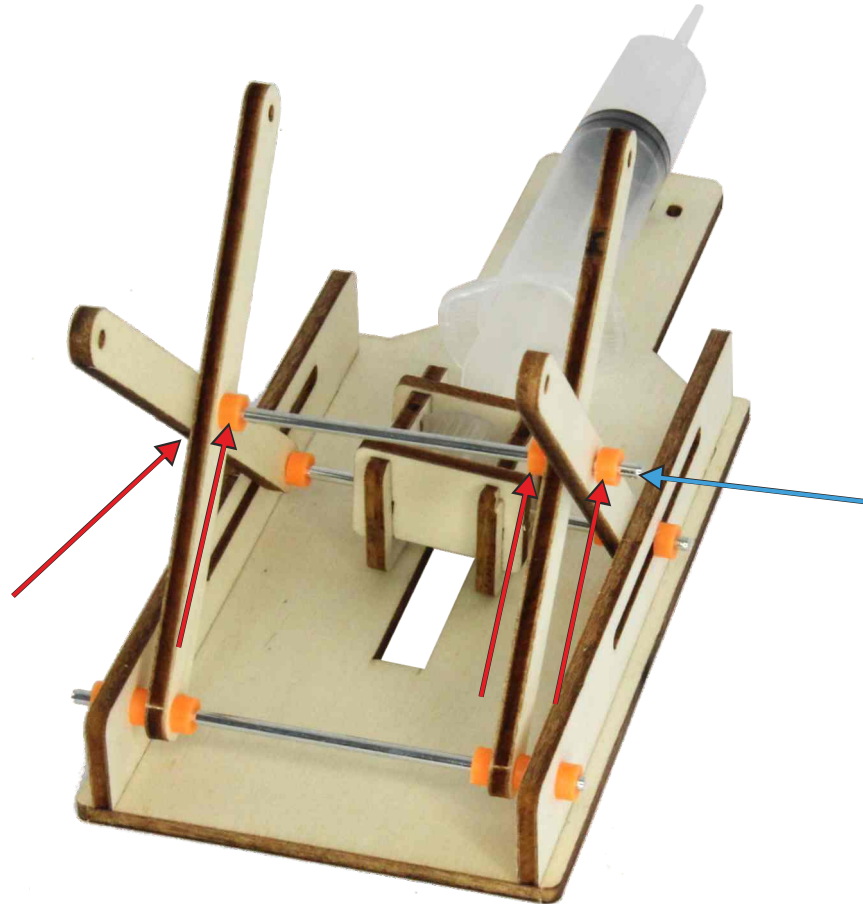

E

Ⓔ

4 x

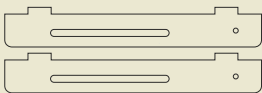
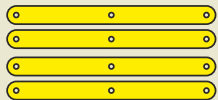

8 x



2 x

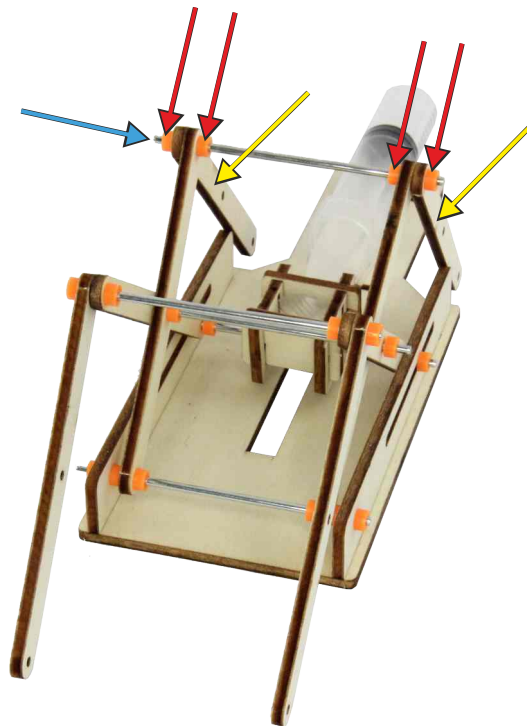
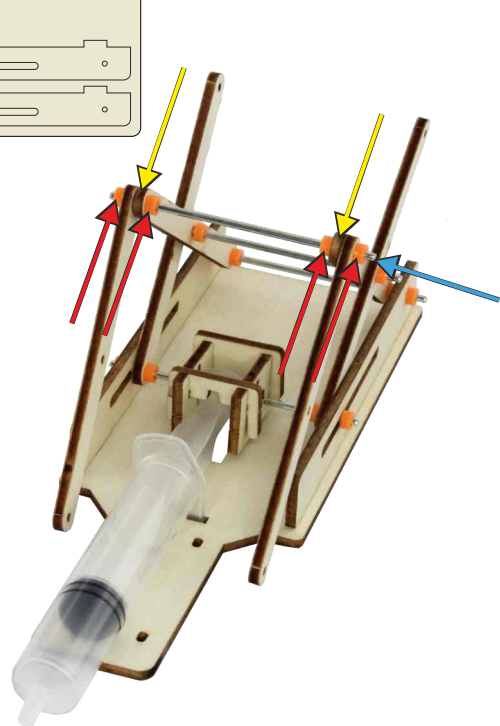

F

4 x 

1 x 

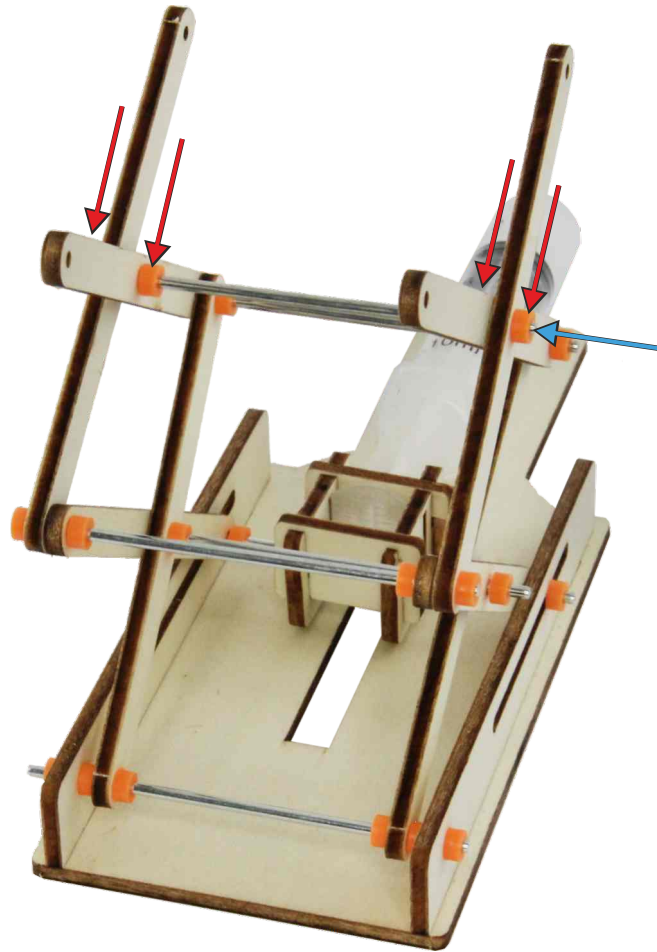

G

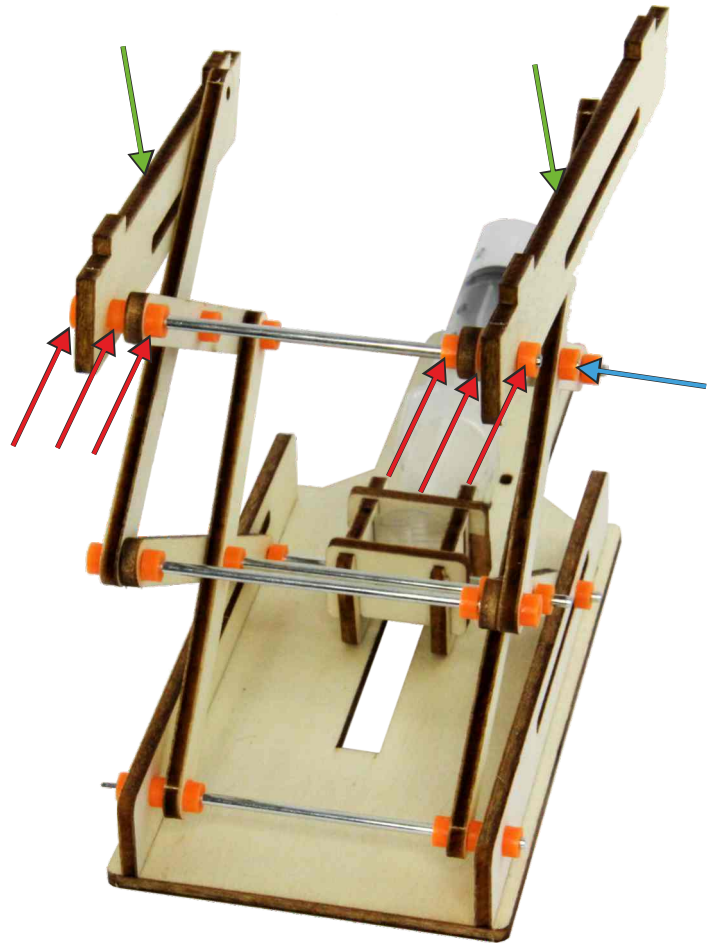
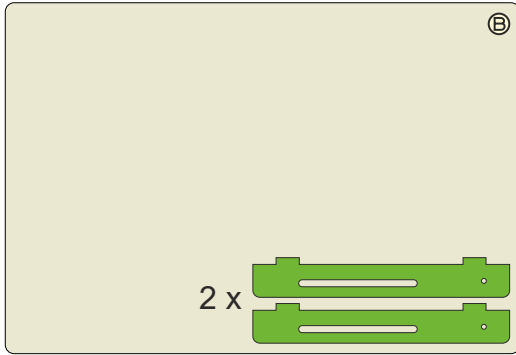

H

4 x

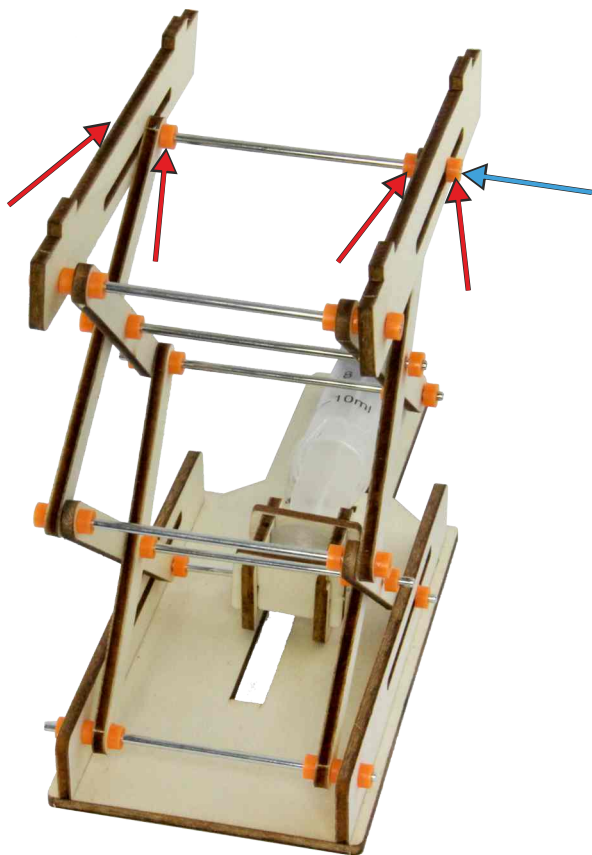
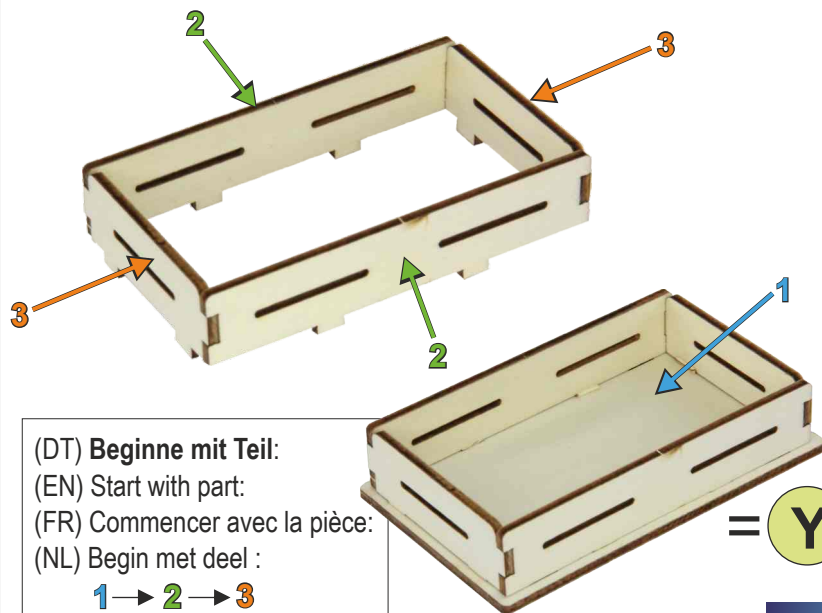
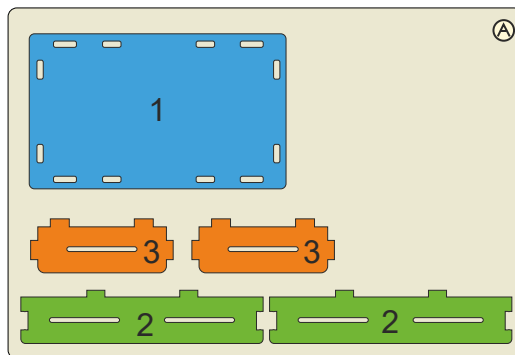

1 x

**I**

(DT) **Beginne mit Teil:**
 (EN) Start with part:
 (FR) Commencer avec la pièce:
 (NL) Begin met deel :

1 → 2 → 3

= **Y**



J

2 x 

1 x 

1 x 

1 x 