

OMNIMATE Data - RJ45 jacks transformer RJ45M R12D 3.2N4G/Y RL

Weidmüller Interface GmbH & Co. KG
Klingenbergstraße 16
D-32758 Detmold
Germany
Fon: +49 5231 14-0
Fax: +49 5231 14-292083
www.weidmueller.com



RJ45 transmitter sockets (magnetics) for gigabit applications (1000 base-T) with integrated compensation actively counteracts inductive and capacitive couplings and saves space on the PCB.

The product range encompasses the following designs:

- 90°, lying (horizontal) and 180°, standing (vertical)
- latch up / latch down
- THT, THR or SMD soldering processes
- Wide range of different design types, also with integrated LEDs and shield contact tabs
- Transmission rates of up to 1 Gbps
- Packed either in a tray (TY) or on a roll (tape-on-reel, RL)
- Compatible with modular RJ45 connector according to ANSI / TIA-1096-A and IEC 60603
- Dielectric strength ≥ 1500 V AC RMS (2250 V AC peak value) according to IEEE 802.3
- Dielectric strength ≥ 1500 V AC (peak value) or ≥ 1500 V DC according to IEC 60603
- Compliance with IEEE 802.3 requirements (1000Base-T, 1 Gbps, IEEE 802.3ab or 100Base-Tx, 100 Mbps, IEEE 802.3u)

Properties and advantages:

- Extended temperature range of -40 °C to $+85$ °C for maximum performance
- Reinforced gold layer (30μ) for improved corrosion protection

- At least 3 mm stand-off ensures a perfect soldering result

Általános rendelési adatok

Típus	RJ45M R12D 3.2N4G/Y RL
Rendelési szám	2551900000
Verzió	NYÁK dugaszoló csatlakozó, RJ45 jacks transformer, 10/100 MBit/s, THT/THR-forrasztott csatlakozással, 90°, Retesz opció: bottom, Shield tabs: none, 30-80 μ Ni / 30- μ Au, LED: Igen, zöld, sárga, Pólusszám: 8, Tape
GTIN (EAN)	4050118562187
Menny.	200 Stück
Csomagolás	Tape

**OMNIMATE Data - RJ45 jacks transformer
RJ45M R12D 3.2N4G/Y RL**

Weidmüller Interface GmbH & Co. KG
Klingenbergstraße 16
D-32758 Detmold
Germany
Fon: +49 5231 14-0
Fax: +49 5231 14-292083
www.weidmueller.com

Műszaki adatok**Méreték és tömegek**

Szélesség	31,2 mm	Szélesség (coll)	1,228 inch
Magasság	16,7 mm	Magasság (coll)	0,657 inch
Legalacsonyabb változat magassága	13,5 mm	Mélység	21,35 mm
Mélység (coll)	0,841 inch	Nettó tömeg	7,07 g

Hőmérsékletek

Tárolási hőmérséklet, max.	85 °C	Tárolási hőmérséklet, min.	-40 °C
Üzemi hőmérséklet, max.	85 °C	Üzemi hőmérséklet, min.	-40 °C

Termék környezetvédelmi megfelelése

REACH SVHC	Lead 7439-92-1
------------	----------------

System specifications

Colour of left LED	zöld	Colour of right LED	sárga
Csatlakozás típusa	Aljzatos csatlakozó	Dugaszolási ciklusok	750
Felszerelés NYÁK-ra	THT/THR-forrasztott csatlakozással	Forrasztószem furatátmérője (D)	0,9 mm
Forrasztószem furatátmérőjének tűrése (D)	± 0,1 mm	Forrasztótűskék száma pólusonként	1
Kimenő könyök	90°	LED	Igen
Osztás, inch (P)	0,05 inch	Osztás, mm (P)	1,27 mm
Pólusszám	8	Retesz opció	bottom
Shield tabs	none	Termékcsalád	OMNIMATE Data - RJ45 jacks transformer
Védelmi osztály	IP20	Árnyékolás	Igen
Árnyékolás felülete	nikkelezett	Árnyékoló anyag	Sárgaréz
Átviteli sebesség	10/100 MBit/s		

Electrical properties

Névleges feszültség	125 V AC	Névleges áram	1,5 A
Szigetelés erőssége	> 500 MΩ	Átütési szilárdság, érintkező / árnyékolás	1500 V DC
Átütési szilárdság, érintkező / érintkező	≥ 1000 V DC		

Anyagjellemzők

Szigetelőanyag	PA 9T	Szín	fekete
Színkáló (hasonló)	RAL 9011	Szigetelőanyag csoport	II
CTI	≥ 500	Szigetelés erőssége	> 500 MΩ
Moisture Level (MSL)	1	UL 94 éghetőségi osztály	V-0
Érintkező alapanyaga	Foszfor-bronz	Érintkező felület	Arany a nikkel felett
Dugó érintkező rétegének felépítése	30-80 μ" Ni / 30- μ" Au	Tárolási hőmérséklet, min.	-40 °C
Tárolási hőmérséklet, max.	85 °C	Üzemi hőmérséklet, min.	-40 °C
Üzemi hőmérséklet, max.	85 °C		

Csomagolás

Csomagolás	Tape	VPE hosszúság	0 m
VPE szélesség	0 m	VPE magasság	0 m
Dobos tekercs átmérője Ø (A)	330 mm	Felületi ellenállás	Rs = 10 ⁹ - 10 ¹² Ω

**OMNIMATE Data - RJ45 jacks transformer
RJ45M R12D 3.2N4G/Y RL**

Weidmüller Interface GmbH & Co. KG
Klingenbergstraße 16
D-32758 Detmold
Germany
Fon: +49 5231 14-0
Fax: +49 5231 14-292083
www.weidmueller.com

Műszaki adatok**Besorolások**

ETIM 6.0	EC002637	eClass 6.2	27-25-05-04
eClass 9.0	27-44-04-02	eClass 9.1	27-44-04-02

Jóváhagyások

Jóváhagyások



ROHS Megfelel

Letöltések

Engineering Data	STEP
Product Change Notification	PCN PCN

**OMNIMATE Data - RJ45 jacks transformer
RJ45M R12D 3.2N4G/Y RL**

Weidmüller Interface GmbH & Co. KG
Klingenbergstraße 16
D-32758 Detmold
Germany
Fon: +49 5231 14-0
Fax: +49 5231 14-292083
www.weidmueller.com

Méretrajz

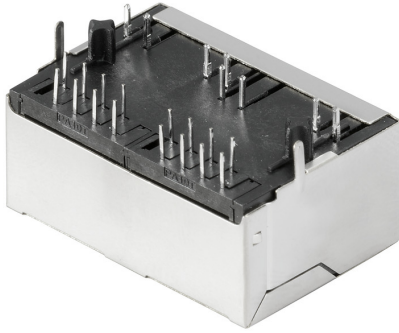

Méretrajz

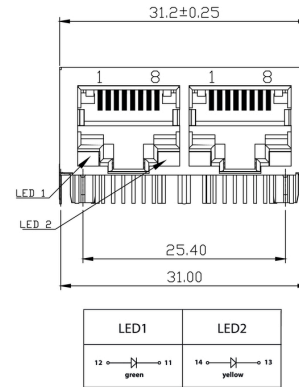

Méretrajz

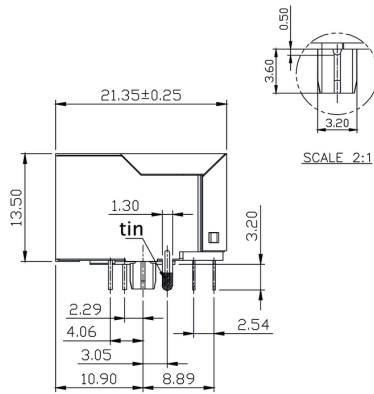

Méretrajz

Kapcsolási rajz

NYÁK kivitel

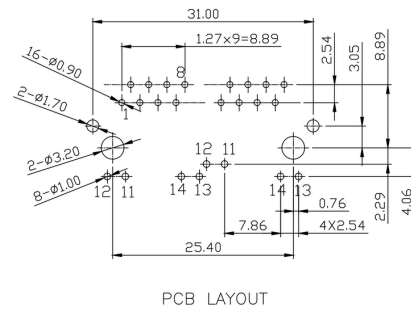

**OMNIMATE Data - RJ45 jacks transformer
RJ45M R12D 3.2N4G/Y RL**

Weidmüller Interface GmbH & Co. KG
 Klingenbergstraße 16
 D-32758 Detmold
 Germany
 Fon: +49 5231 14-0
 Fax: +49 5231 14-292083
 www.weidmueller.com

Kapcsolási rajz

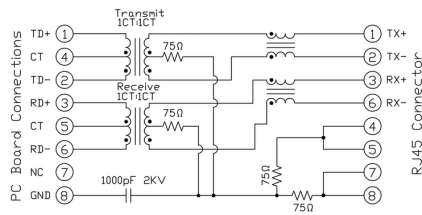

OMNIMATE Data - RJ45 jacks transformer RJ45M R12D 3.2N4G/Y RL

Weidmüller Interface GmbH & Co. KG
 Klingenbergstraße 16
 D-32758 Detmold
 Germany
 Fon: +49 5231 14-0
 Fax: +49 5231 14-292083
 www.weidmueller.com

Rajzok

Schematic

Characteristics

Inductance	350 µH min. @ 100 kHz, 100 mV, 8 mA DC Bias
Leakage Inductance	0.3 µH max. @ 100 kHz, 100 mV
Insertion Loss	1.1 dB max. @ (1 - 100) MHz
Return Loss	18 dB min. @ (1 - 30) MHz 16 dB min. @ (30 - 60) MHz 12 dB min. @ (60 - 80) MHz
Cross Talk	30 dB min. @ (1 - 100) MHz
Common Mode Rejection	30 dB min. @ (1 - 100) MHz

Type codes

Type Code	Parameter	Value	Description
RJ45	Product	RJ45	Product
G1	Performance Category	G1	Category 5, 10/100/1000 Mbit
R	Assembly on PCB	R	Through Hole Reflow - THR
I	Direction, latch style	I	Horizontal (90°, side entry), latch up
U	Number of Ports	U	1 Port
3.2	Solder Pin length	3.2	3.2 mm
E	EMI tabs (ground fingers)	E	E = with EMI tabs
4	Contact surface thickness	4	1 = 3µ", 2 = 6µ", 3 = 15µ", 4 = 30µ", 5 = 50µ"
GY/GY	LED	GY/GY	Green-Yellow/Green-Yellow
TY	Packaging	TY	Tray in box (manual assembly)
		RL	Tape on Reel (automated assembly)
		Y/G	Yellow/Green
		G/Y	Green/Yellow (standard)
		GY/GY	Green-Yellow/Green-Yellow
		O/G	Orange/Green
		R/O	Red/Orange
	 (further combinations possible)
		N	without LED
		D	SMD
		V	Vertical (180°, top entry)
		Y	Diagonal (45°), latch up
		1	1 Port
		12; 14; ...	multi ports side by side, Multiport
		2; 4; ...	multi ports about each other, Multilevel
		S	Surface Mount Technology - SMT
		T	Through Hole Technology - THT
		C5	Category 5
		C6	Category 6
		C6A	Category 6A
		C5e	Category 5e
		M	10/100 Mbit
		G1	10/100/1000 Mbit
		G10	10 Gbit
		U	Unshielded
		MP	10/100 Mbit with POE
		MP+	10/100 Mbit with POE+

Recommended wave soldering profiles

Weidmüller Interface GmbH & Co. KG
 Klängenbergstraße 16
 D-32758 Detmold
 Germany
 Fon: +49 5231 14-0
 Fax: +49 5231 14-292083
 www.weidmueller.com

Single Wave:



Double Wave:



Wave soldering profiles

Wired connection elements should be processed in accordance with the DIN EN 61760-1 standard. We have included two recommendations for practical wave soldering profiles, with which Weidmüller PCB terminals and connectors are qualified.

When choosing a suitable profile for your application, the following factors also need to be considered:

- PCB thickness
- Proportion of Cu in the layers
- Single/double-sided assembly
- Product range
- Heating and cooling rates

The single and double wave profiles each indicate the recommended operating range, including the maximum soldering temperature of 260°C. In practice, the maximum soldering temperature is quite often well below the above maximum profile.

Recommended reflow soldering profile

Weidmüller Interface GmbH & Co. KG
 Klingenbergstraße 16
 D-32758 Detmold
 Germany
 Fon: +49 5231 14-0
 Fax: +49 5231 14-292083
 www.weidmueller.com



Reflow soldering profile

The perfect soldering profile for SMT Surface Mount Technology is one the most exiting question in SMT production. But there are more than one correct answer: The diagram of temperature-on-time is related to processing features of solder paste and to maximum load of components.

We have to consider the following parameters:

- Time for pre heating
- Maximum temperature
- Time above melting point
- Time for cooling
- Maximum heating rate
- Maximum cooling rate

We recommend a typical solder profile with associated process limits. With preheating components and board are prepared smoothly for the solder phase. Heating rate is typically $\leq +3\text{K/s}$. In parallel the solder paste is ‚activated‘. The time above melting point of 217°C the paste gets liquid and components and boards begin to connect. The maximum temperature of 245°C to 254°C should stay between 10 and 40 seconds. In the cooling phase at $\geq -6\text{K/s}$ solder is cured. Board and components cool down while avoiding cold cracks.