

Schaltschrank-Systeme
Enclosure systems
Systèmes d'armoires électriques
Schalttafelssystemen
Apparatkaşisistemleri
Sistemi di armadi per quadri di comando
Sisternas de armarios
エレクトロニクス架



Elektronika-Aufbau-Systeme EL
Electronic systems EL
Systèmes de montage électroniques EL
Elektronica-opbouwsystemen EL
Elektroniksystem EL
Sistemi di allestimento EL per l'elettronica industriale
Sisternas de montaje electrónica EL
エレクトロニクス架



Schaltschrank-Klimatisierung und Maschinenkühlung SK
Enclosure climate control and machine cooling SK
Clim. d'armoires et refroidissement de machines SK
Schalttafelklimatisierung en machinecoöling SK
Apparatkaşisistemlendirme och maskinsoöling SK
Climatizzazione per armadi di comando e raffreddamento impianti
Climatizacja per armarios Y maşinlerin SK
エレクトロニクス架 用気調システム 冷却機 SK



Stromverteilungs-Komponenten SV
Power distribution components SV
Composants de distribution de courant SV
Stromverdelingskomponenten SV
Stromfordelingskomponenter SV
Componenti SV per la distribuzione di corrente elettrica
Componentes de distribución de corriente SV
システム 配電システム SV



Datenübertragungs-Komponenten DK
Data communication components DK
Composants de distribution de données Informal. DK
Data-overdragskomponenter DK
Dataöverdragskomponenter DK
Armad e conanitori DK per trasmissione dati e telefonia
Componentes de la transmisión de datos
システム 通信用システム DK

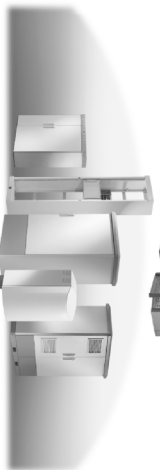

Outdoor-Gehäuse OS
Outdoor enclosures OS
Armoires outdoor OS
Outdoor-behuzingen OS
Utomhuskäskä OS
Armad modular OS per applicazioni da esterno
Cajas para la intemperie OS
システム トラフシステム CS

Rittal GmbH & Co. KG · Postfach 1692 · D-38726 Heberhorn
Fabeon (02172) 905-0 · Telefon (02172) 905-2319 · eMail: info@rittal.de · Internet: http://www.rittal.de

Rittal DK

neues Bild wird
nachgereicht

- Lüfterblech
- Fan mounting plate
- Toile d' aération
- Ventilatieplaat
- Luftstyrplåt
- Kit di ventilazione
- Placa de montaje para el ventilador

7966.035
7968.035
7986.035
7988.035

- Montageanleitung
- Assembly instructions
- Notice de montage
- Montage-instructie
- Montageanvisning
- Istruzioni di montaggio
- Instrucciones de montaje
- 取扱説明書

Umschalten auf Perfektion **RITTAL**

Umschalten auf Perfektion **RITTAL**

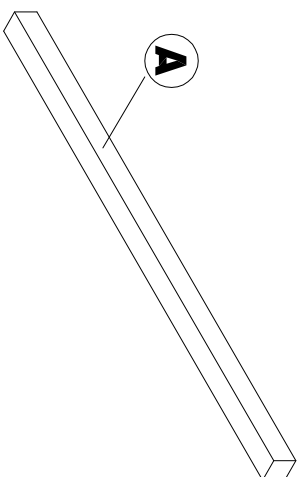
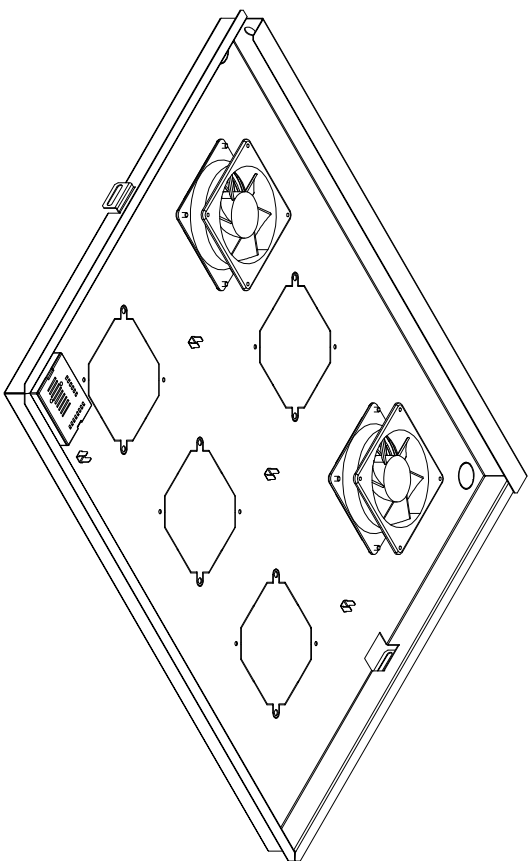

2x **A**

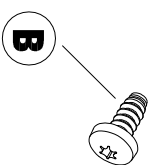

5,5x13

2x **B**

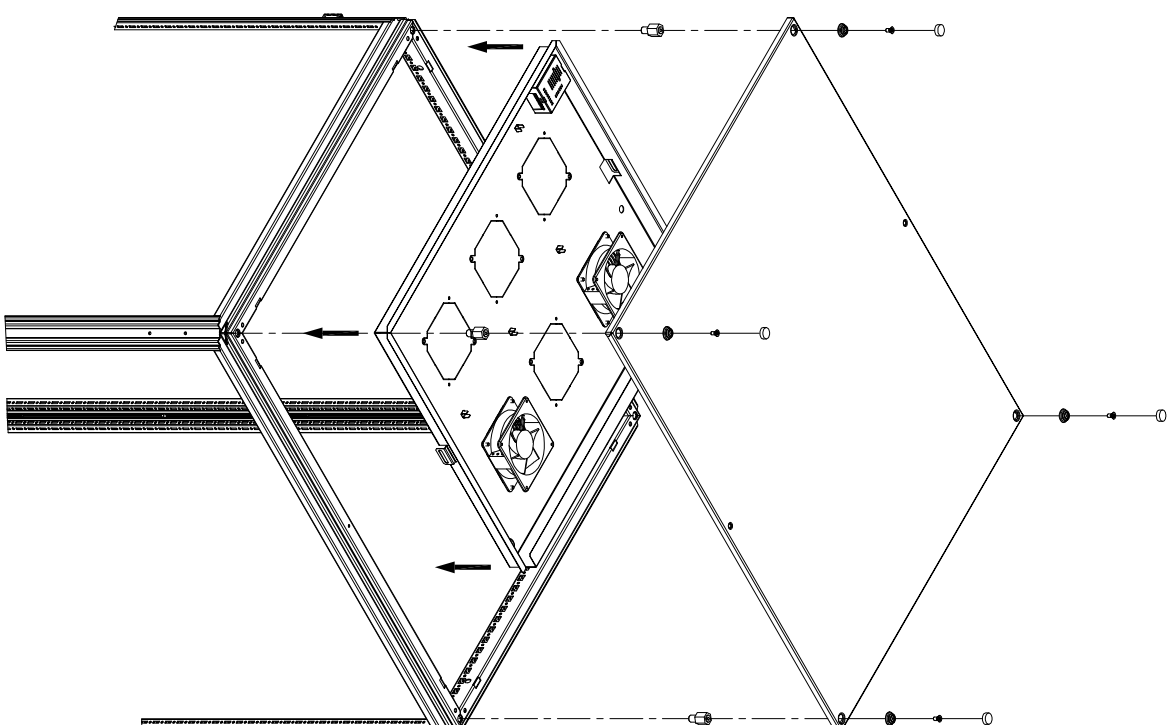

DK 7826.766 DK 7826.786
 DK 7826.768 DK 7826.788
 DK 7826.769 DK 7826.789
 DK 7826.760 DK 7826.780

DK 7826.866
 DK 7826.886
 DK 7826.896
 DK 7826.806

3 Nm

DK 7826.669 DK 7826.869
 DK 7826.689 DK 7826.889
 DK 7826.699 DK 7826.899
 DK 7826.609 DK 7826.809

DK 7826.645 DK 7826.845
 DK 7826.665 DK 7826.865
 DK 7826.685 DK 7826.885
 DK 7826.695 DK 7826.895
 DK 7826.605 DK 7826.805
 DK 7826.625 DK 7826.825

SZ 2423.000 (20mm)
 SZ 7967.000 (50mm)

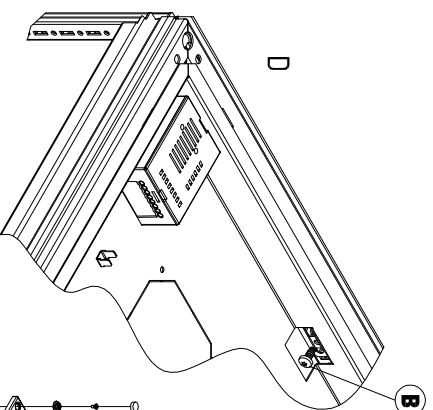
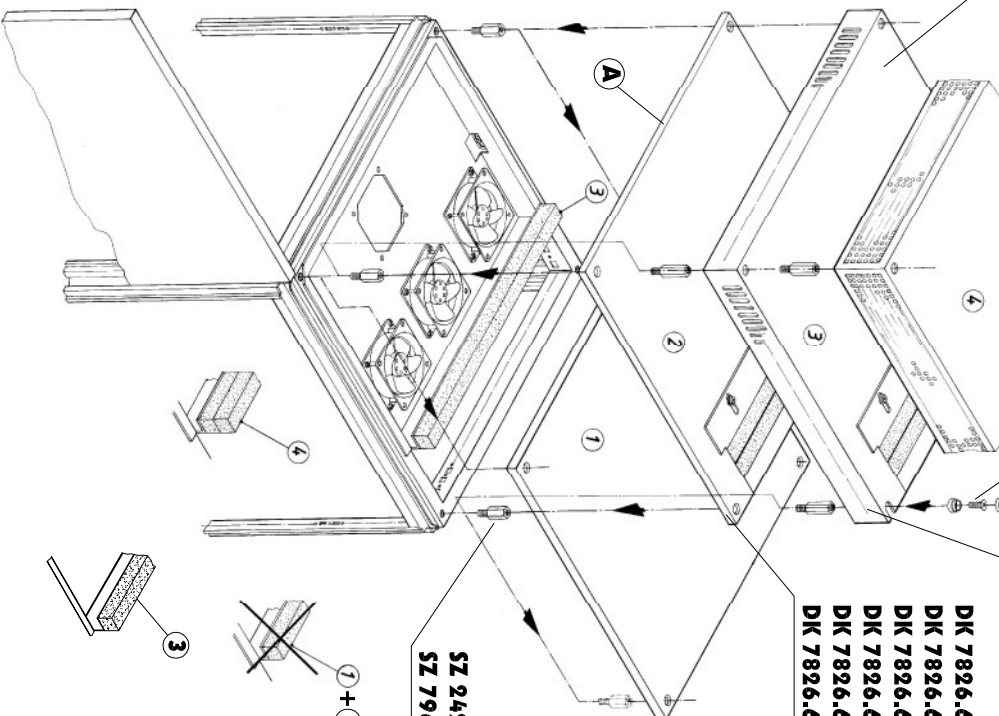

Einbausituation mit Schwenkrahmen
 Installation position with swing frame
 Position d'installation avec cadre pivotant
 Inbouwpositie In combinatie met zwenkraam
 Inbyggnadsituation med svängram
 Punto die installazione con telaio girevole
 Posición de fijación con bastidor móvil

