



Instruction Manual Book

Item code: BH163.

DORNIER DO335

NOT INCLUDING ELECTRIC GEAR RETRACTS.
ONLY INCLUDING OLEO STRUTS.
ALL Balsa - PLY WOOD CONSTRUCTION.
COVERED IN A HEAT-SHRINK FILM WITH PRINTED.



95% ALMOST READY TO FLY

SPECIFICATION:

- Wingspan: 1,724mm (67.87in).
- Length: 1,731mm (68.15 in).
- Weight: 6 kg (13.2lbs).
- Wing area: 61.4dm².
- Wing loading: 97.72g/dm².
- Wing type: Naca Airfoil.
- Servo mount: 42mm x 21mm.
- Gear type: Electric retract gear, size: (92.2 x 51 x 30.6)mm (*not included*).
- Oleo struts (*included*).
- Spinner (2pcs): 80mm.

Parts listing required (not included):

- Radio: 06 channels.
- Servo: 07 servos.
- Motor (2pcs) : Brushless outrunner 1000-1800W, 800KV.
- Propeller (2pcs): Suit with your engine.

Recommended Motor

and battery set up (not included):

- Motor (2pcs): RIMFIRE.55
- Lipo cell: 6 cells 5,000mAh.
- ESC (2pcs) : 60A.

This instruction manual is designed to help you build a great flying aeroplane. Please read this manual thoroughly before starting assembly of your **DORNIER DO335**. Use the parts listing below to identify all parts.

WARNING

Please be aware that this aeroplane is not a toy and if assembled or used incorrectly it is capable of causing injury to people or property. WHEN YOU FLY THIS AEROPLANE YOU ASSUME ALL RISK & RESPONSIBILITY.

If you are inexperienced with basic R/C flight we strongly recommend you contact your R/C supplier and join your local R/C Model Flying Club. R/C Model Flying Clubs offer a variety of training procedures designed to help the new pilot on his way to successful R/C flight. They will also be able to advise on any insurance and safety regulations that may apply.

SUGGESTION

To avoid scratching your new airplane, do not unwrap the pieces until they are needed for assembly. Cover your workbench with an old towel or brown paper, both to protect the aircraft and to protect the table. Keep a couple of jars or bowls handy to hold the small parts after you open the bag.

NOTE

Please trial fit all the parts. Make sure you have the correct parts and that they fit and are aligned properly before gluing! This will assure proper assembly **DORNIER DO335**. ARF is hand made from natural materials, every plane is unique and minor adjustments may have to be made. However, you should find the fit superior and assembly simple.

The painted and plastic parts used in this kit are fuel proof. However, they are not tolerant of many harsh chemicals including the following: paint thinner, C/A glue accelerator, C/A glue debonder and acetone. Do not let these chemicals come in contact with the colors on the covering and the plastic parts.

Caution: This model is not a toy!

If you are a beginner to this type of powered model, please ask an experienced model flyer for help and support. If you attempt to operate the model without knowing what you are doing you could easily injure yourself or somebody else. Please keep your safety and well-being in mind at all times.

Important: Before you start construction

Even if you have built a large number of RC models

please read right through these instructions and check all the kit components against the parts list. We have taken great trouble to keep construction as simple as possible, without making any compromises in the area of safety.

Note regarding the film covering

Minor creases or bubbles may develop in the film covering due to major fluctuations in weather conditions (temperature, humidity etc.); in rare cases you may even find a slight warp in a component. These minor faults are in the nature of film-covered built-up wooden structures, and can easily be corrected using a heat gun, as commonly used for modelling.

Creases: Blow warm air over the area and rub down with a soft cloth.

Wing wrap: Hold the panel twisted gently in the opposite direction to the wrap, and apply warm air to remove the creases from the covering.

Caution! do not heat the film more than is absolutely necessary. If the air or the iron is too hot, the film may melt and holes may be formed.

This model is highly pre-fabricated and can be built in a very short time. However, the work which you have to carry out is important and must be done carefully. The model will only be strong and fly well if you complete your tasks competently - so please work slowly and accurately.

When self-tapping screws have to be screwed into wood, apply a little white glue to prevent them shaking loose: just squirt white glue into the hole and fit the screw

TOOLS & SUPPLIES NEEDED



Cyanoacrylate Glue.

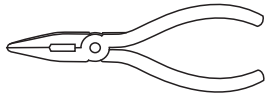

Needle nose Pliers.

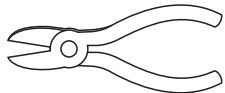

Wire Cutters.

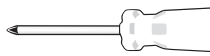

Philip screw driver



Threadlocker (screw cement).



Phillips head screwdriver.

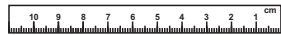

Straight edge ruler.



Epoxy Glue (5 minute type).
Epoxy Glue (30 minute type).

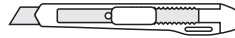

Hobby knife.



Awl.

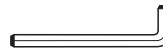

Hex Wrench.



Hand or electric drill.

Some more tools.

- Assorted drill bits.
- 2mm ball driver.
- 90° square or builder's triangle.
- Masking tape & T-pins.
- Paper towels.

PARTS LISTING



Suit with your engine.

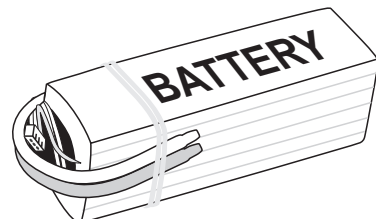
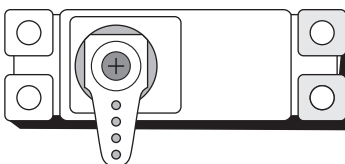
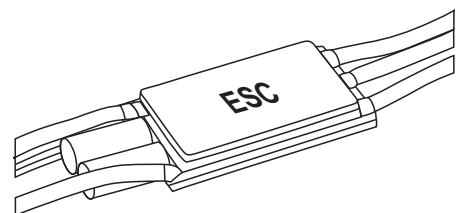
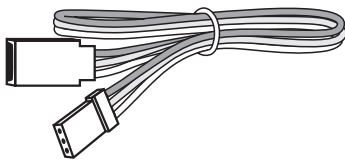
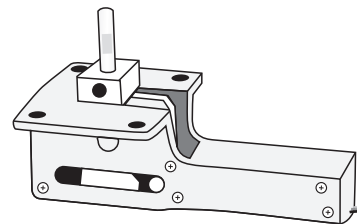
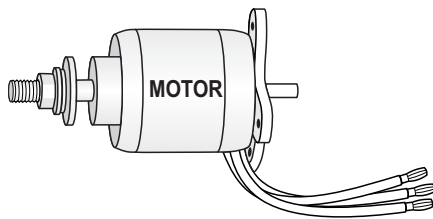

- ① : Fuselage.
- ② : Wing panel (2a, 2b).
- ③ : Horizontal stabilizer (3a, 3b).
- ④ : Rudder (4a, 4b).
- ⑤ : Aluminium wing dihedral brace.
- ⑥ : Cowling (6a, 6b).
- ⑦ : Spinner.
- ⑧ : Air intake.
- ⑨ : Cockpit fuselage (9a : Canopy, 9b : Pilot, 9c : Cockpit).
- ⑩ : Aluminium tube horizontal stabilizer.

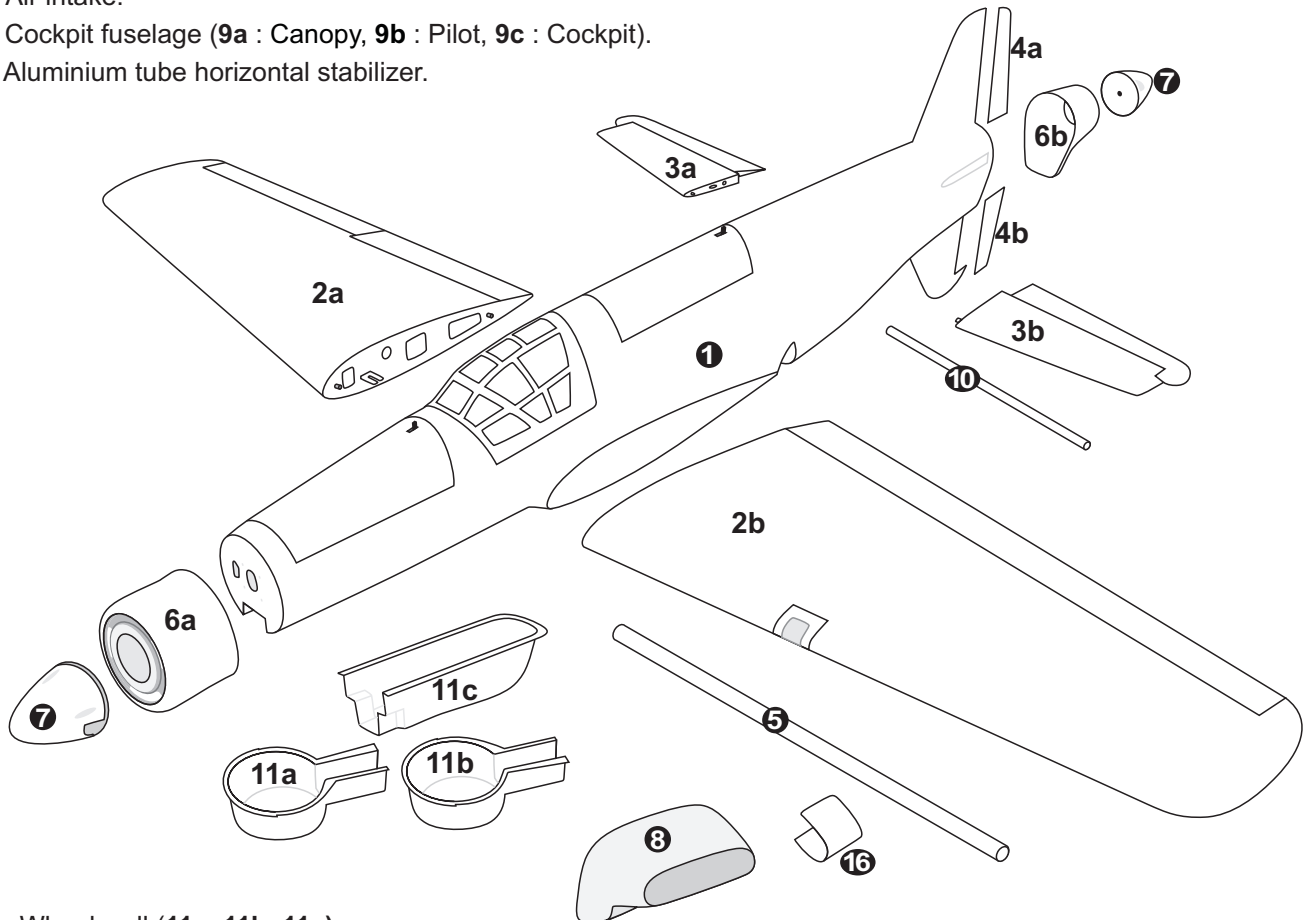
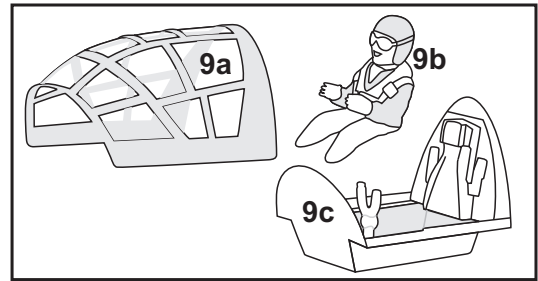

- ⑪ : Wheel well (11a, 11b, 11c).
- ⑫ : Plastic parts of fuselage (12a, 12b, 12c).
- ⑬ : Oleo struts.
- ⑭ : Oleo struts nose gear.
- ⑮ : Wheels (15a, 15b).
- ⑯ : Wing plastic light.

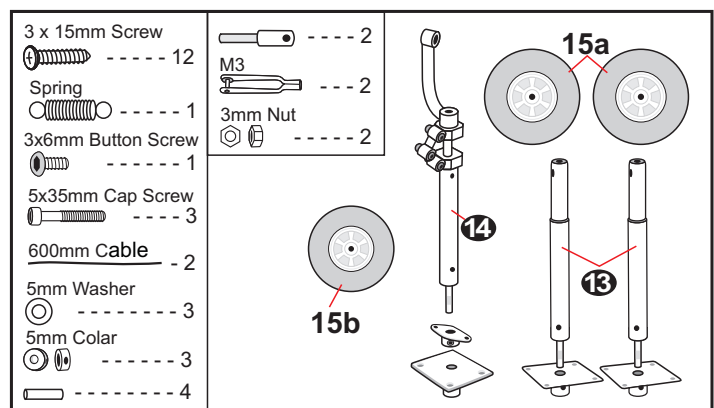
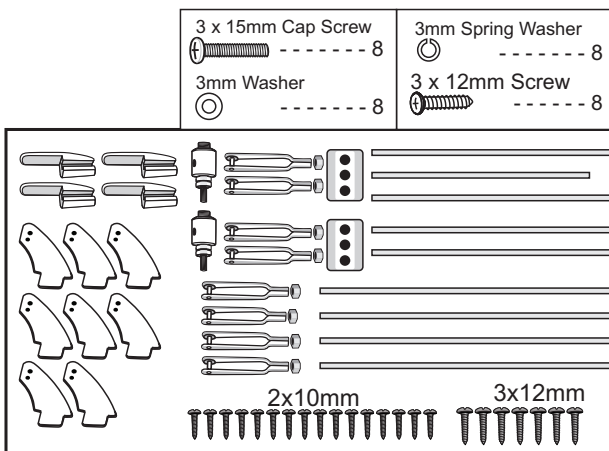
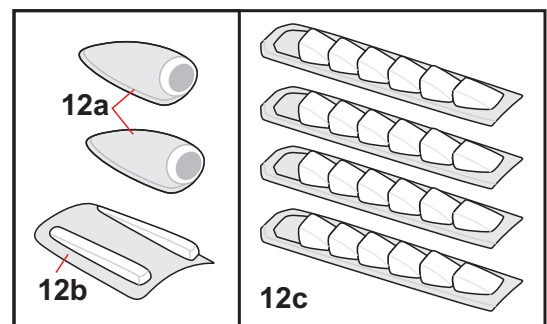

1. INSTALLING THE AILERONS, FLAPS

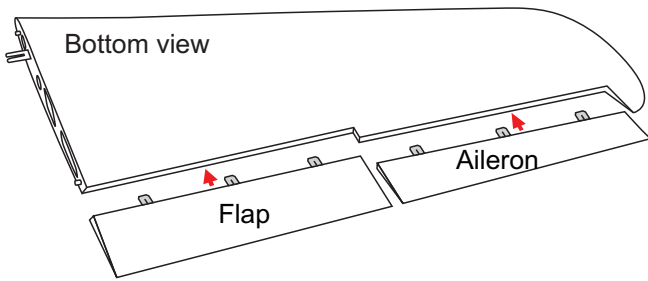

* Test fit the ailerons to the wing with the hinges. If the hinges don't remain centered, stick a pin through the middle of the hinge to hold it in position.

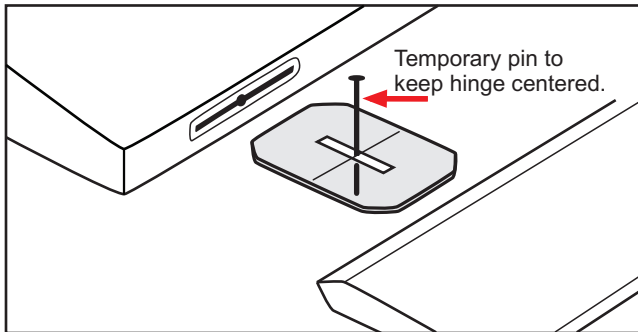

* Apply drops of thin CA to the top and bottom of each hinge. Do not use CA accelerator. After the CA has fully hardened, test the hinges by pulling on the aileron.

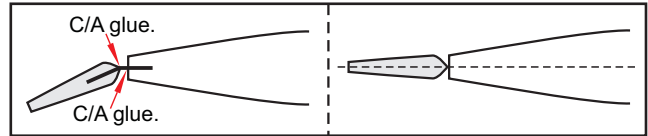

* Secure nylon hinges with instant glue, being careful not to glue the wing and aileron together.

* Align the center line of main wing with aileron.

WARNING! Make certain the hinges are adequately secured with glue. If they come loose in flight accidents may result.

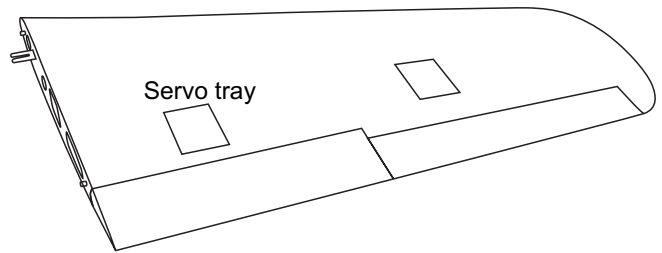

2. INSTALLING THE AILERON SERVOS, FLAPS

1. Install the rubber grommets and brass eyelets on to the aileron servos.

2. Using a modeling knife, remove the covering from over the pre-cut servo arm exit hole on the aileron servo tray / hatch. This hole will allow the servo arm to pass through when installing the aileron pushrods.

3. Place the servo into the servo tray. Center the servo within the tray and drill 1.5mm pilot holes through the block of wood for each of the four mounting screws provided with the servo.

4. Using the thread as a guide and using masking tape, tape the servo lead to the end of the thread: carefully pull the thread out. When you have pulled the servo lead out, remove the masking tape and the servo lead from the thread.

5. Place the servo into the servo tray/ hatch into the servo box on the bottom of the wing and drill 1.5mm pilot holes through the tray and servo box for each of the four mounting screws. Secure the servo tray in place using the mounting screws provided.

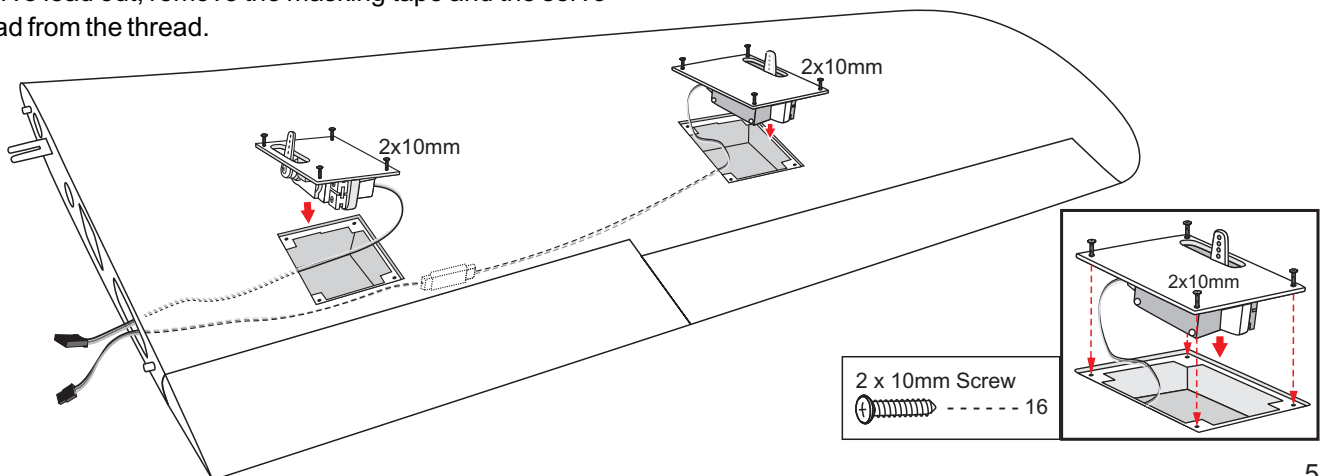
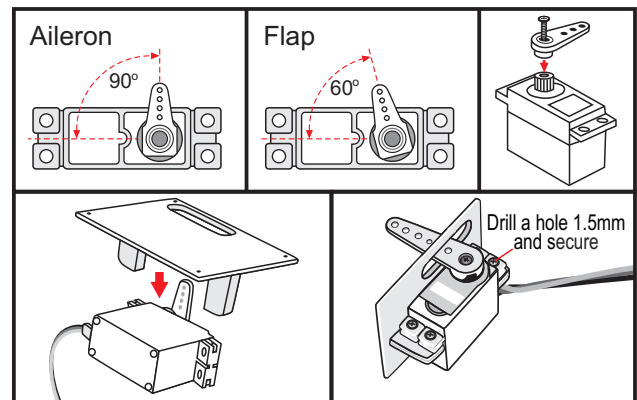

3. INSTALLING THE CONTROL HORNS, LINKAGES

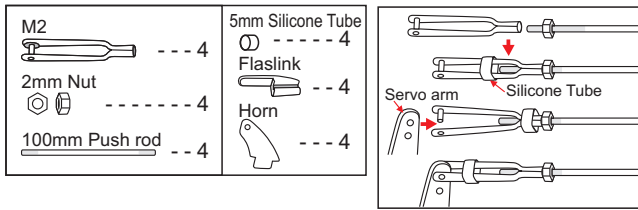

Insert the 90 degree bend down through the hole in the control horn. Install one nylon snap keeper over the wire to secure it to the control horn. Install the control horn retaining screw and remove the masking tape from the aileron.

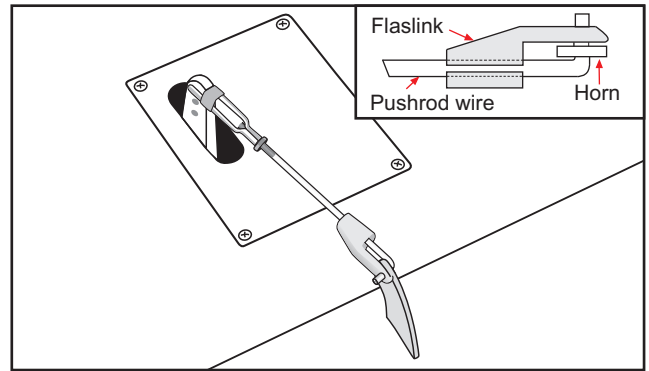
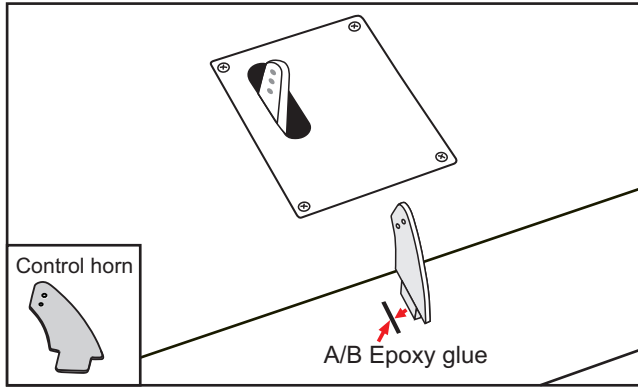

- * Attach the clevis to the outer hole in the servo arm. Install a silicone tube on the clevis.
- * Using pliers, carefully make a 90 degree bend down at the mark made. Cut off the excess wire, leaving about 6mm beyond the bend.

After both linkages are completed, connect both of the aileron servo loads using a Y-harness you have purchased.

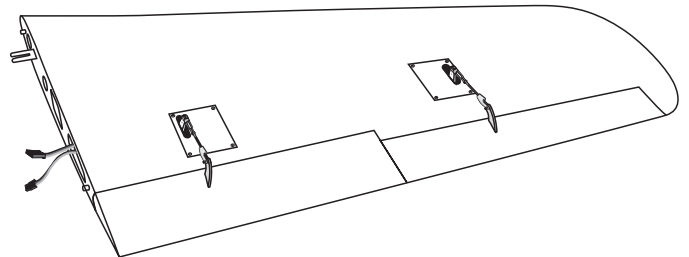
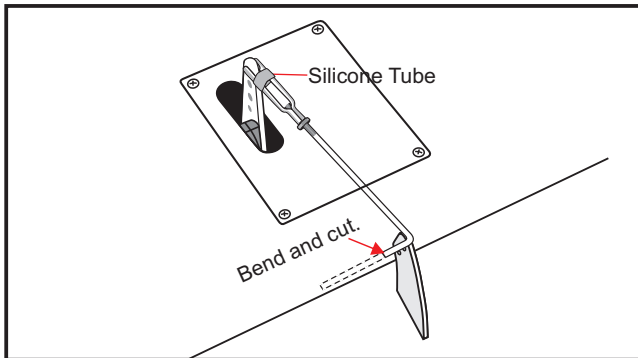

Repeat the procedure to install the other wing.

4. INSTALLING THE ELECTRIC MOTOR, COWLING

3 x 15mm Cap Screw	---
3mm Washer	---
3mm Spring Washer	---
3 x 12mm Screw	---

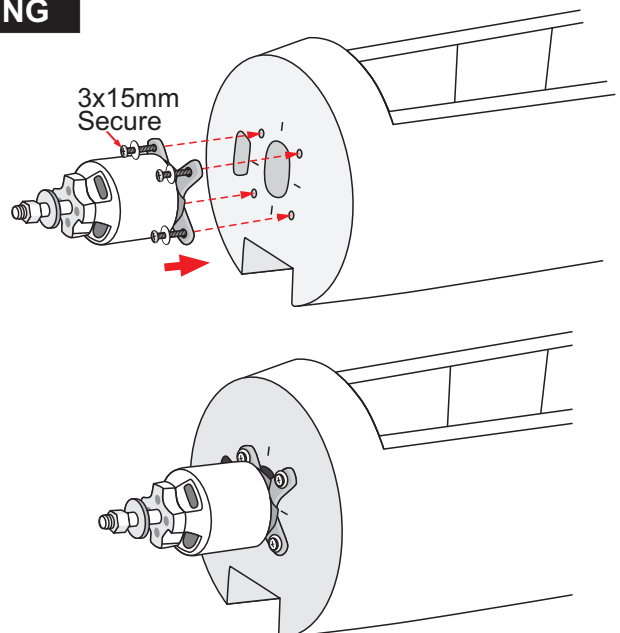
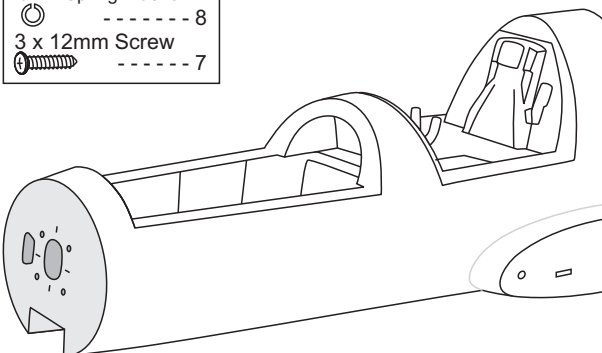

- 1) Slide the fiberglass cowl over the **motor** and line up the back edge of the cowl with the marks you made on the fuselage.
- 2) While keeping the back edge of the cowl flush with the marks, align the front of the cowl with the crankshaft of the **motor**. The front of the cowl should be positioned so the crankshaft is in **nearly** the middle of the cowl opening. Hold the cowl firmly in place using pieces of masking tape.
- 3) Slide the cowl back over the **motor** and secure it in place using three wood screws. See picture below.
- 4) Drill three 2.5mm pilot holes through both side of the cowl and the side edges of the firewall. Using a 3mm drill bit, enlarge the three holes in the cowling.

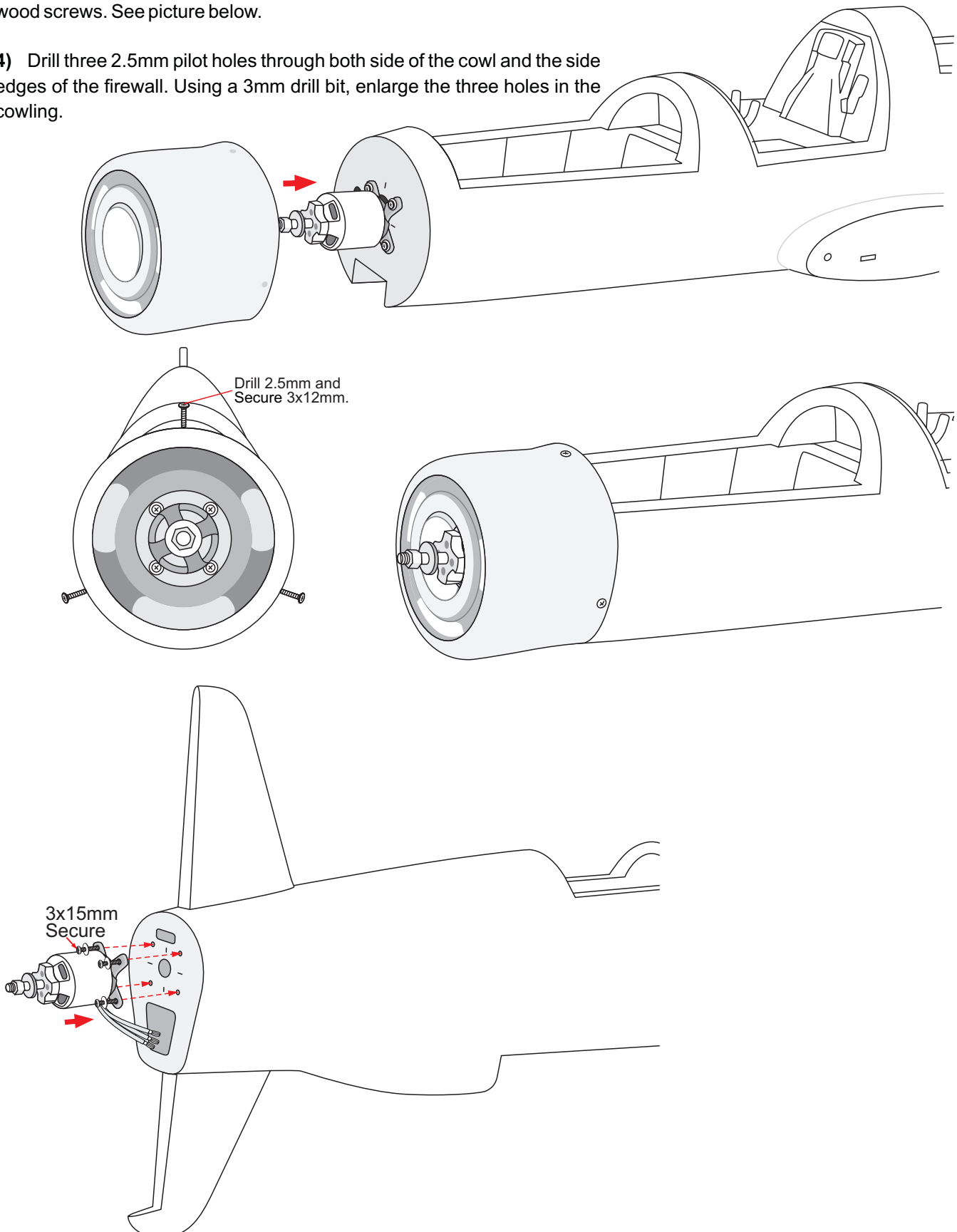

5) Drill four 2.5mm pilot holes through both side of the cowl and the side edges of the firewall. Using a 3mm drill bit, enlarge the four holes in the cowling.

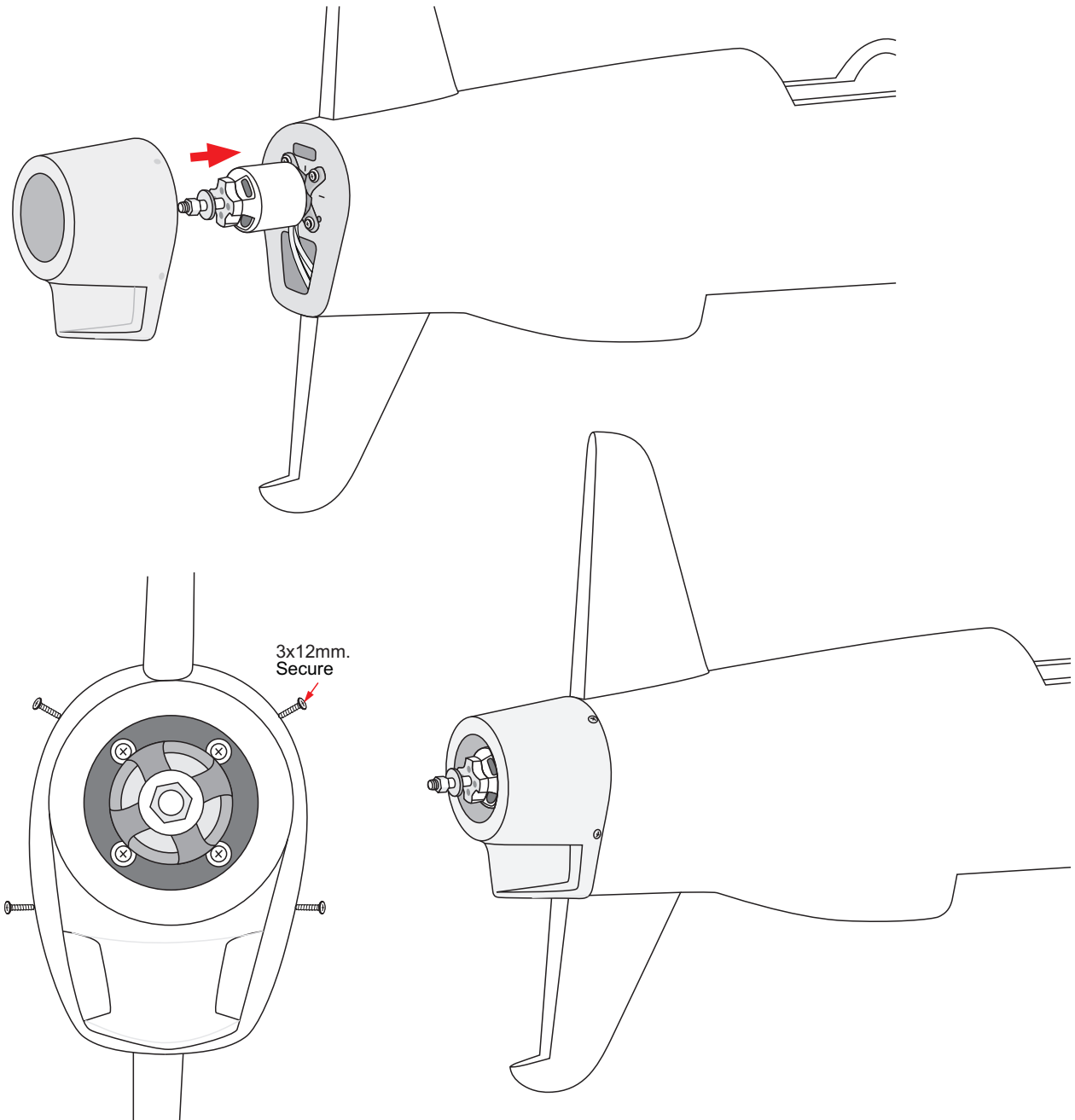

5. INSTALLING THE FUSELAGE SERVOS

1) Install the rubber grommets and brass collets into the elevator, rudder and throttle servos. Test fit the servos into the servo tray. Trim the tray if necessary to fit your servos.

2) Mount the servo to the tray using the mounting screws provided with your radio system.

Fuselage top side

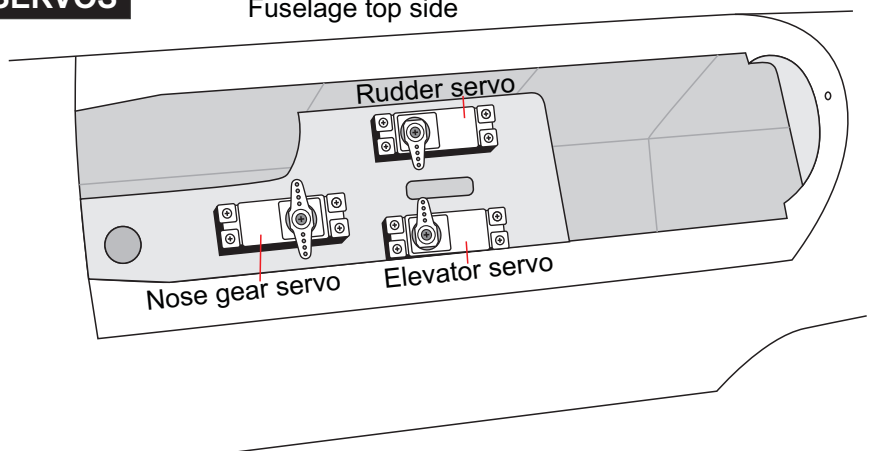

6. RUDDER INSTALLATION

Rudders are installed the same way as the aileron before (see page 5).

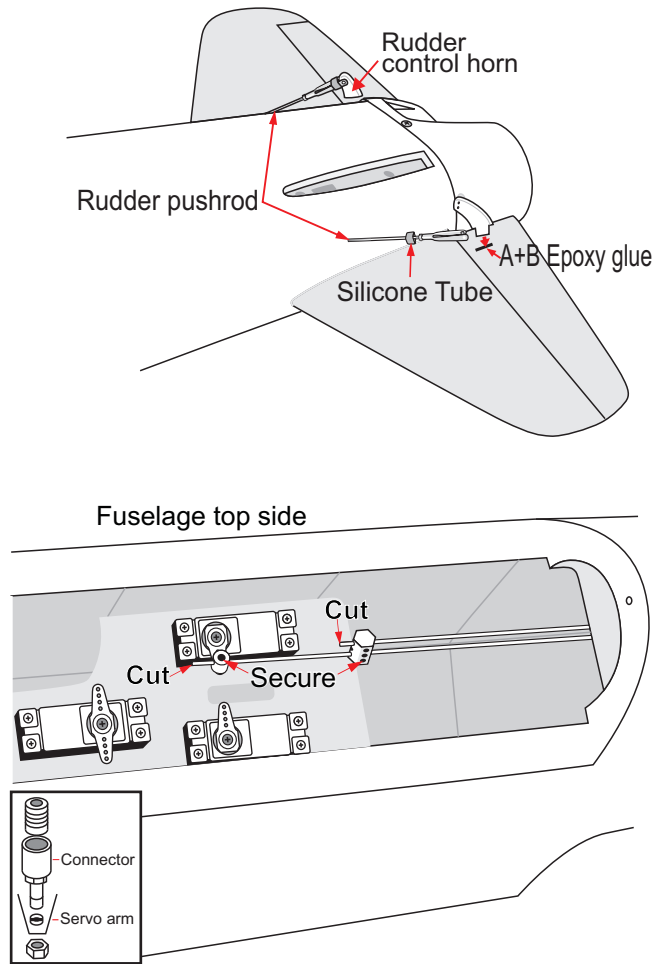
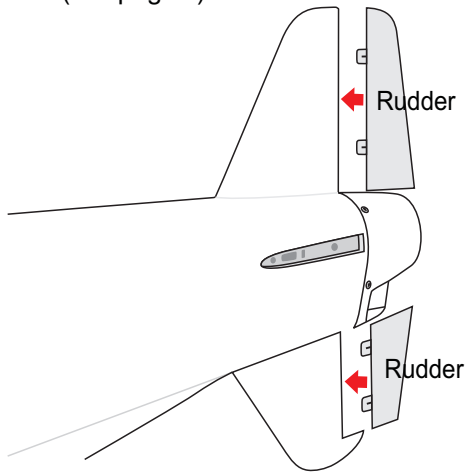

RUDDER CONTROL HORN, PUSHROD INSTALLATION

Rudder control horns, linkages are installed the same way as the aileron before (see page 6).

M2	5mm Silicone Tube	
Nut	Connector	
800 mm Push rod	Horn	

7. INSTALLING HORIZONTAL STABILIZER

1) Elevator are installed the same way as the aileron before (see page 5).

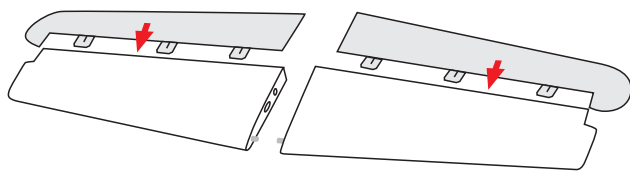

Fuselage Top side

Trim and remove the covering from the tail slots.

M2	5mm Silicone Tube	
Nut	Connector	
800 mm Push rod	Horn	

Aluminium tube.	∅8mm

Attach the aluminium tube into the fuselage.

2) Using a modeling knife, carefully remove the film covering from the tail slots at the rear of the fuselage. Make sure that you do not remove any wood from the slots as this will affect the alignment of the tail.

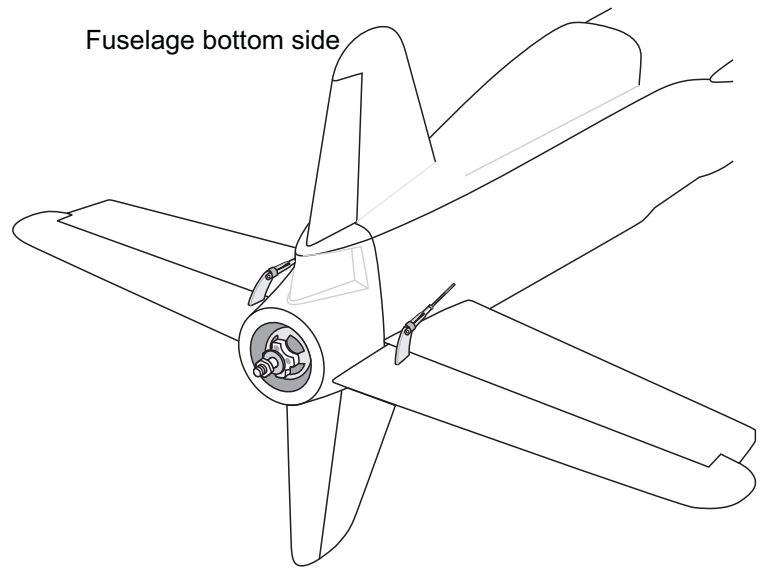
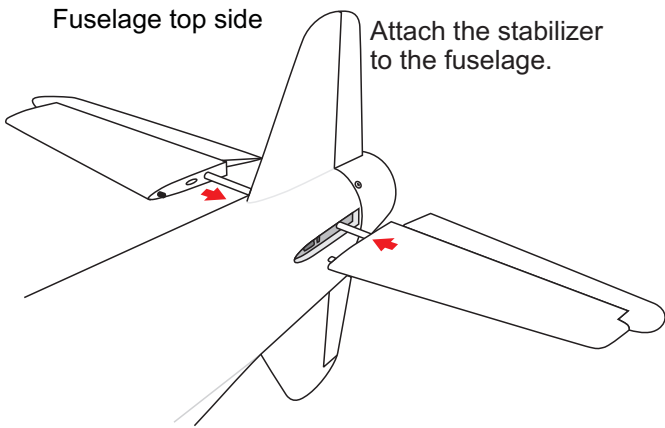

3) Elevator control horns, linkages are installed the same way as the aileron before (see page 6).

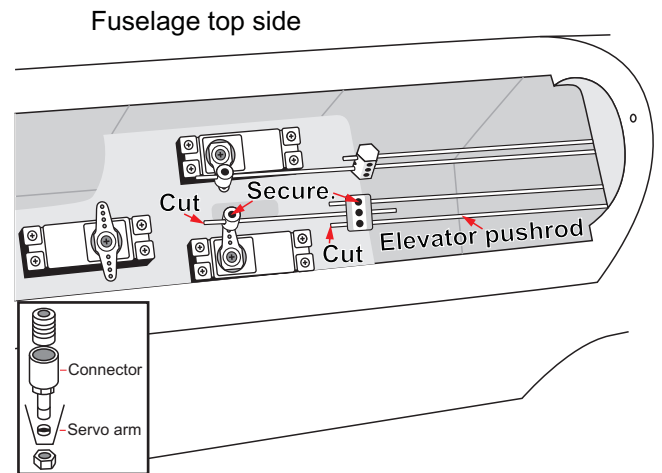
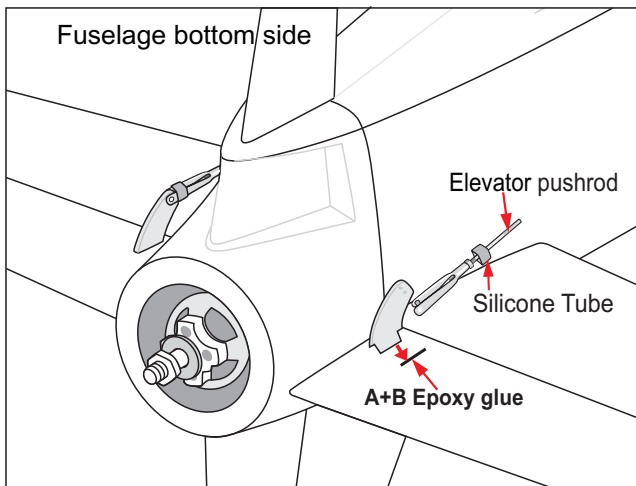

8. INSTALLING THE WHEEL WELL

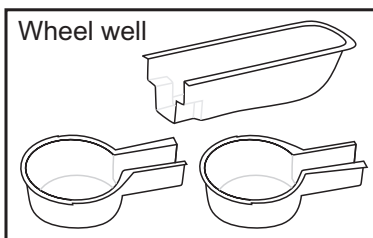

* Using a modeling knife, carefully remove the film covering from the wing gear tray. Make sure that you do not remove any wood.

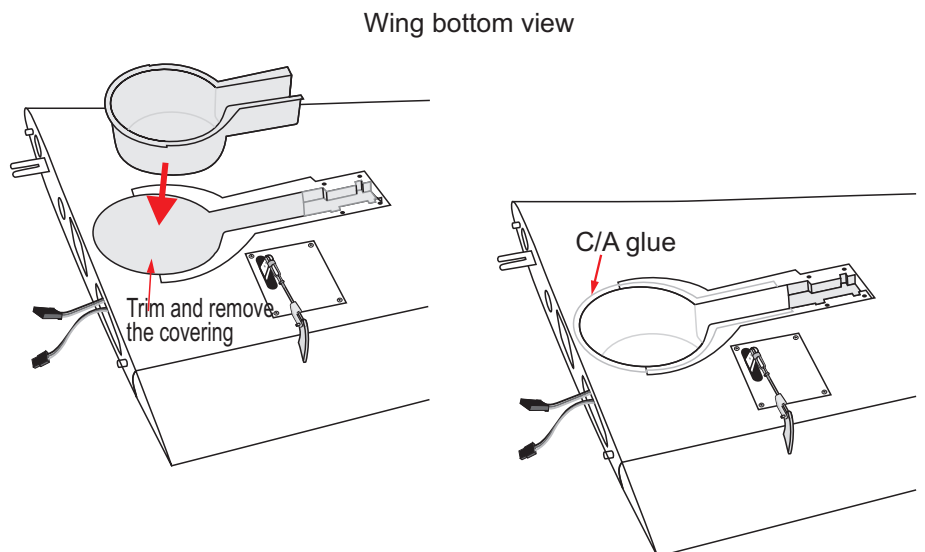

Repeat the procedure to install the opposite gear

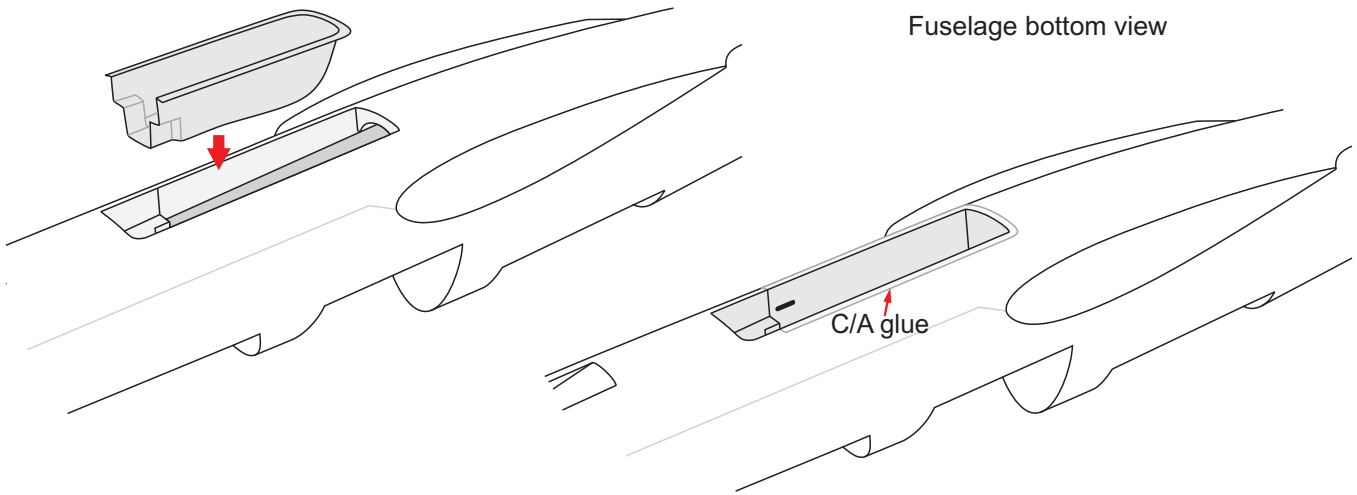

9. INSTALLING MAIN GEAR

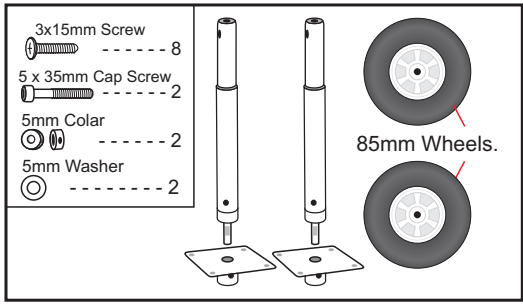

THERE ARE TWO OPTIONS: OPTION 1: MAIN GEAR

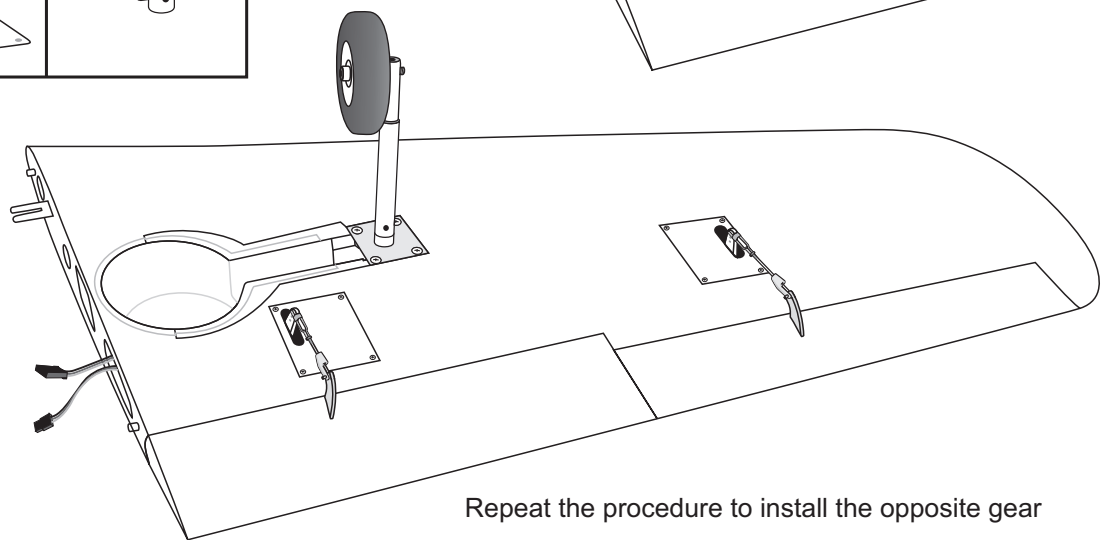
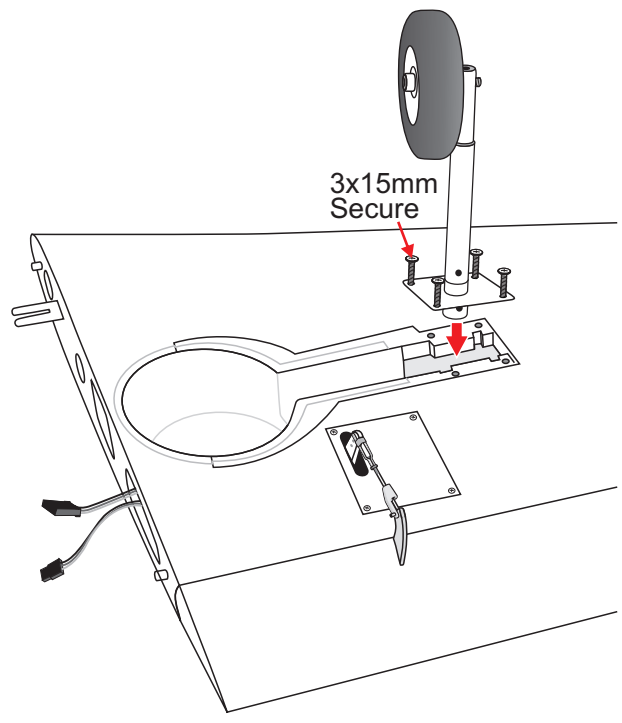
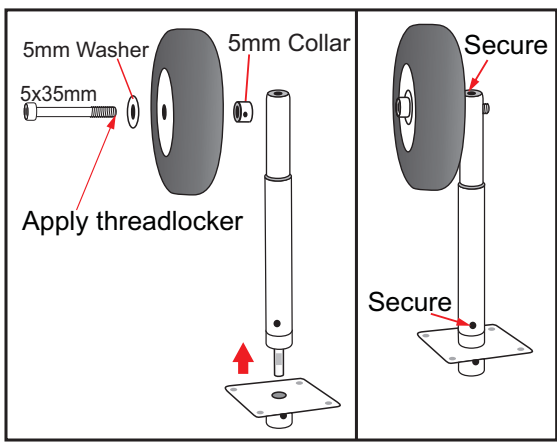

Repeat the procedure to install the opposite gear



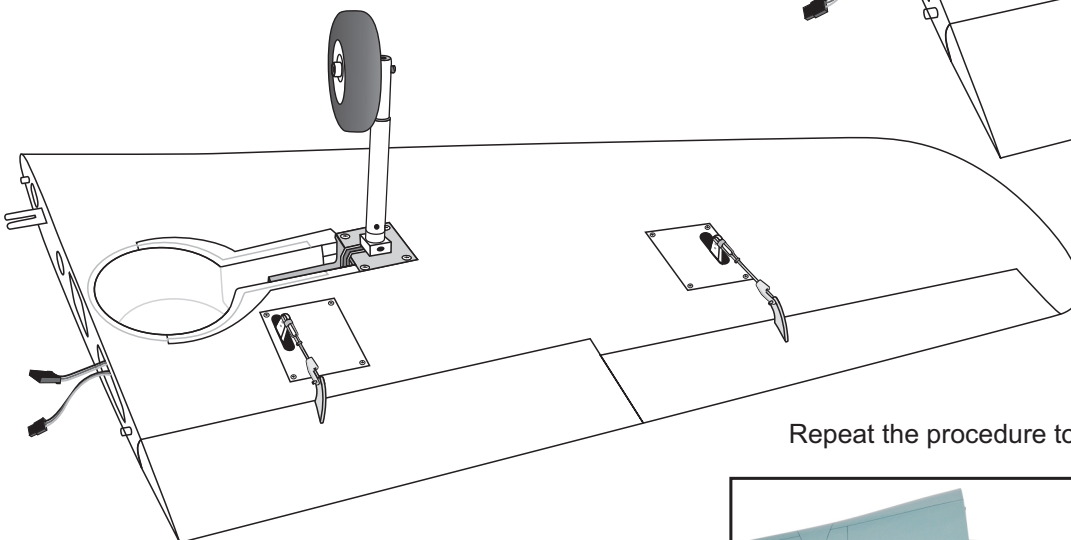
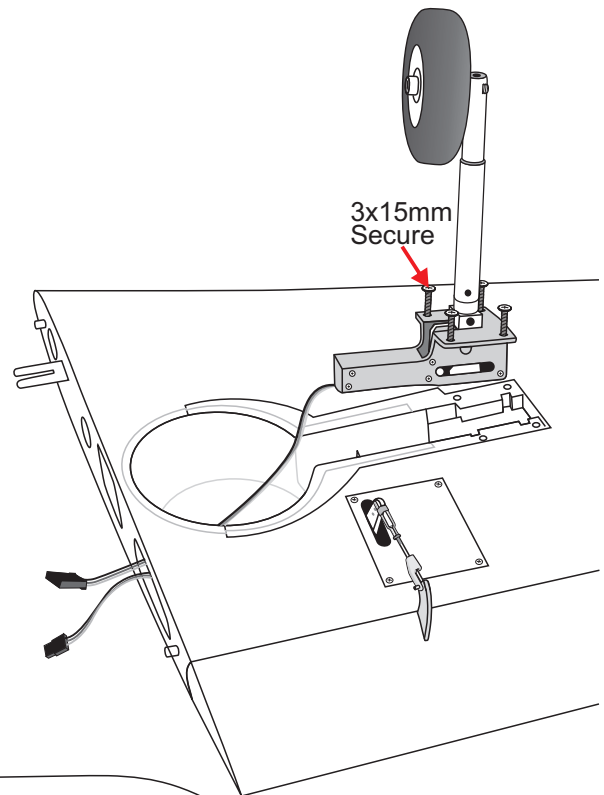
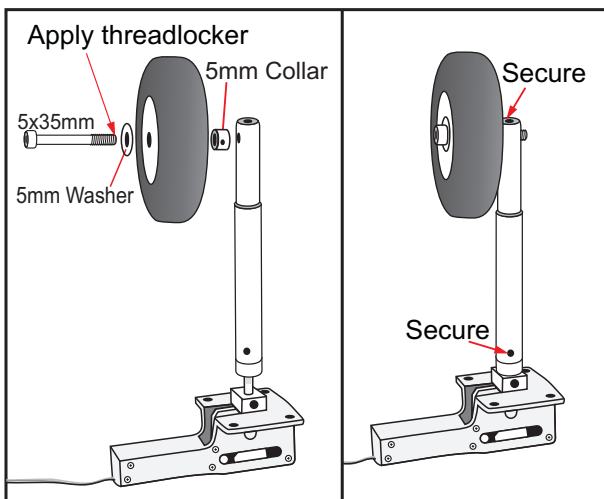
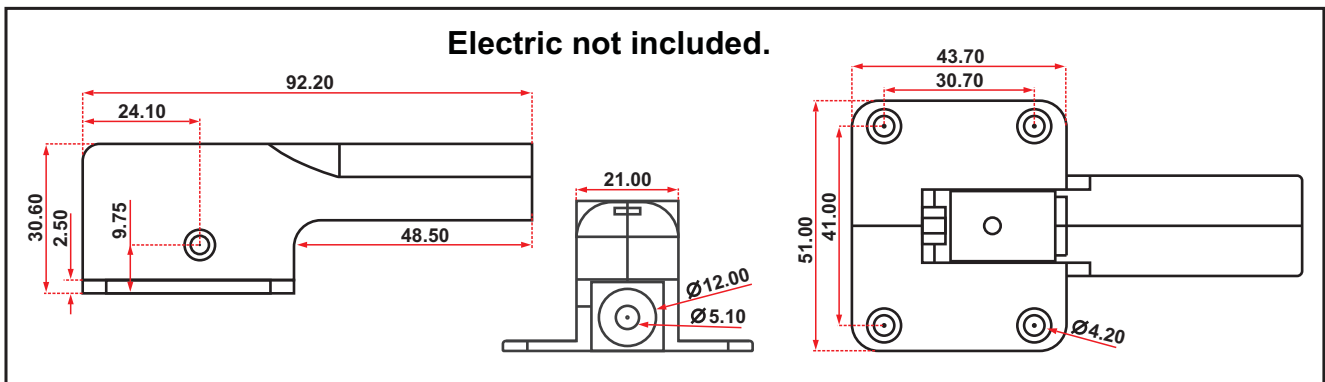



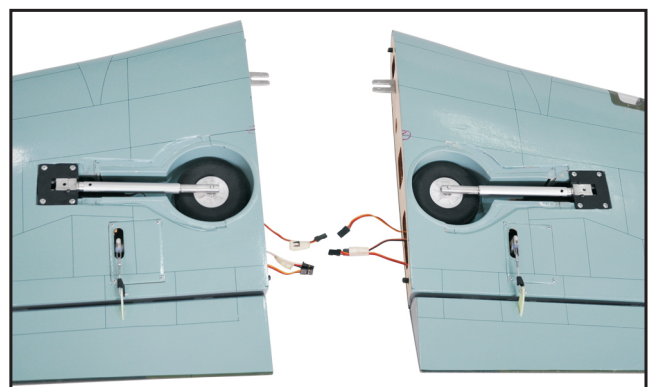



OPTION 2: ELECTRIC GEAR RETRACTS

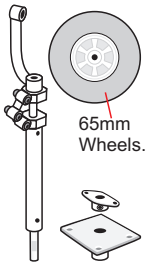

Repeat the procedure to install the opposite gear.



10. INSTALLING THE NOSE GEAR

3 x 15mm Screw  ----- 4	5mm Colar  ----- 1	 65mm Wheels. 
Spring  ----- 1	 ----- 4	
3 x 6mm Button Screw  ----- 1	M3  ----- 2	
5 x 35mm Cap Screw  ----- 1	600mm Cable ----- 2	
5mm Washer  ----- 1	3mm Nut  ----- 2	

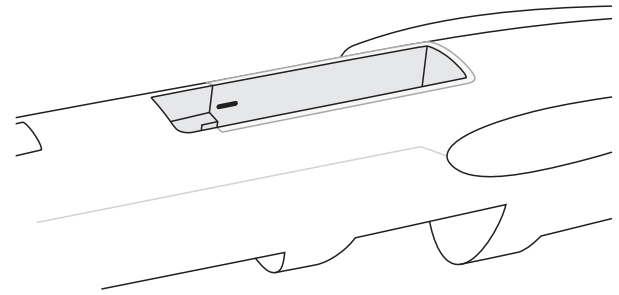

THERE ARE TWO OPTIONS:

OPTION 1

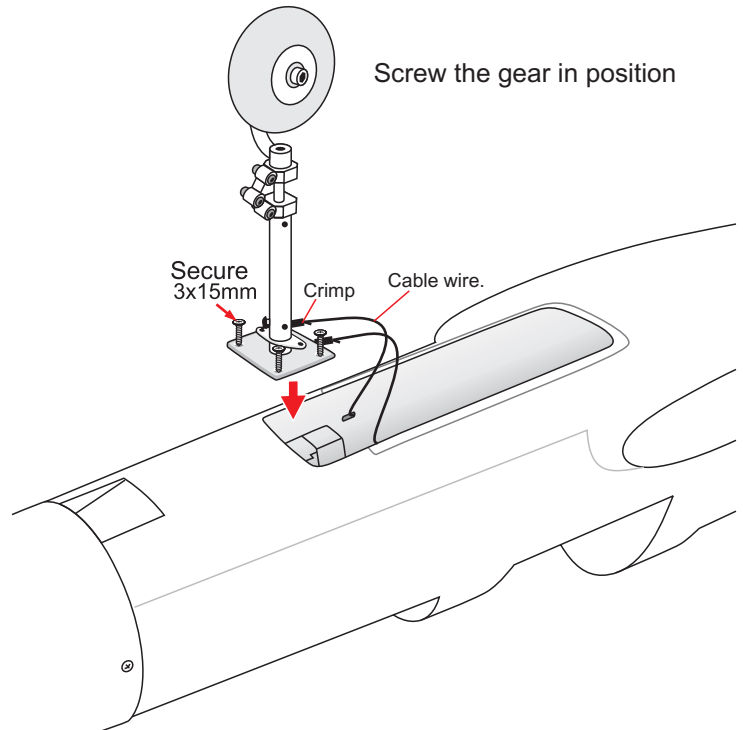
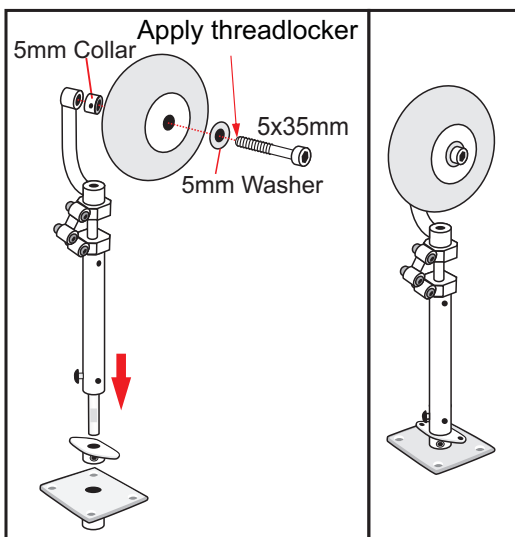

OPTION 2: ELECTRIC GEAR RETRACTS

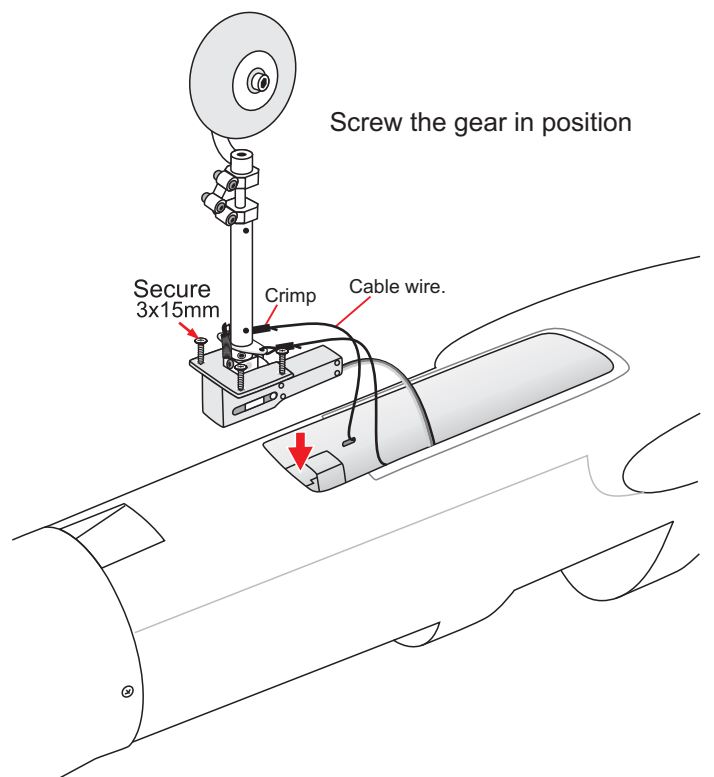
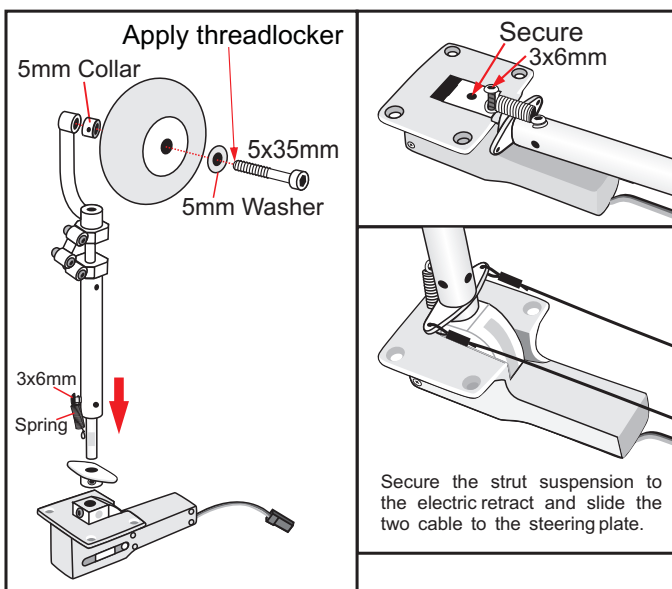

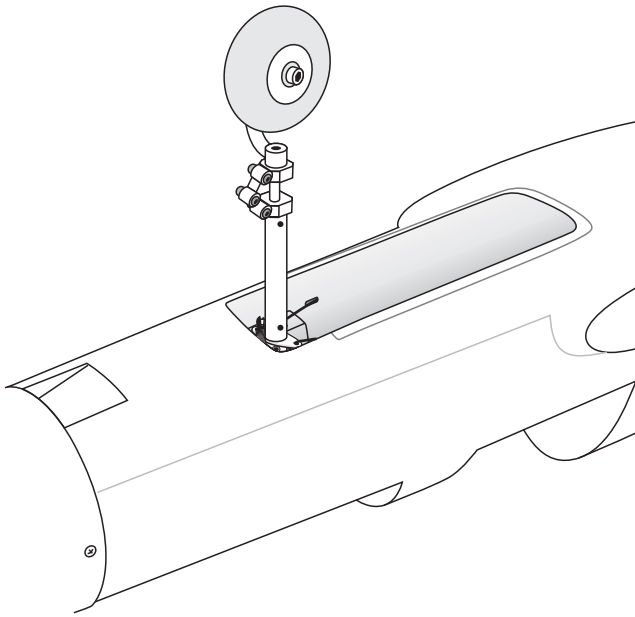

Install two cable to the steering servo nose gear.

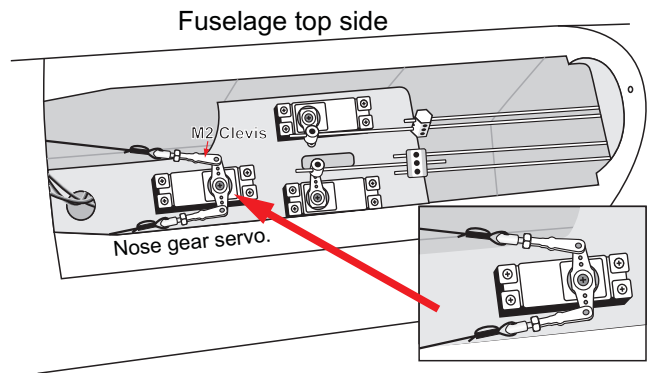

11. INSTALLING THE RECEIVER, ESC AND BATTERY

1) Plug the servo leads and the switch lead into the receiver. You may want to plug an aileron extension into the receiver to make plugging in the aileron servo lead easier when you are installing the wing. Plug the battery pack lead into the switch.

2) Wrap the receiver and battery pack in the protective foam to protect them from vibration. Use a rubber band or masking tape to hold the foam in place.

3) Position the battery pack and receiver behind the fuel tank. Use two tie wraps to hold the battery and receiver securely in place as pictures below. Do not permanently secure the receiver and battery until after balancing the model.

4) Using a 2mm drill bit, drill a hole through the side of the fuselage, near the receiver, for the antenna to exit.

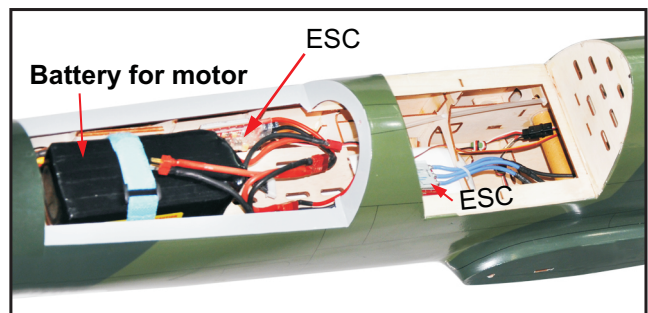

12. WING ATTACHMENT

Locate the aluminium wing dihedral brace.

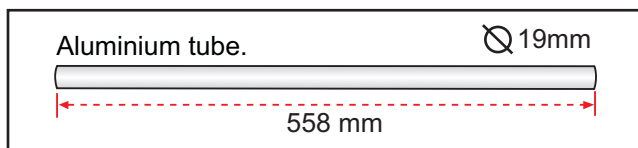

*** Test fit the aluminium tube dihedral brace into each wing haft. The brace should slide in easily. If not, use 220 grit sand around the edges and ends of the brace until it fits properly.

Attach the aluminium tube into the fuselage.

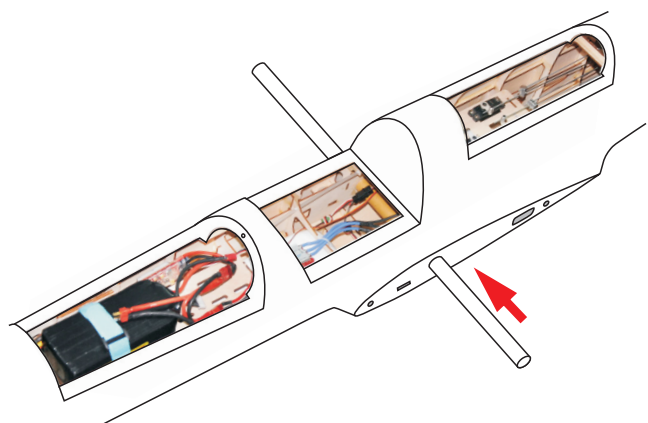

Insert the wing panel as pictures below.

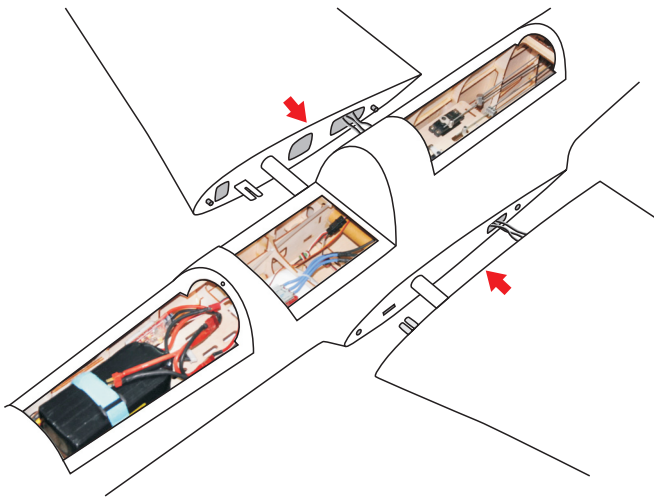

Fuselage bottom side.
Screw the wing panel in position.

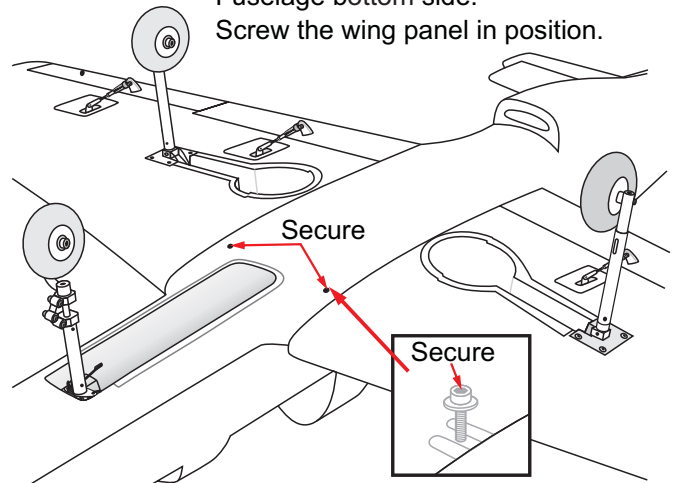

13. INSTALLING COCKPIT FUSELAGE

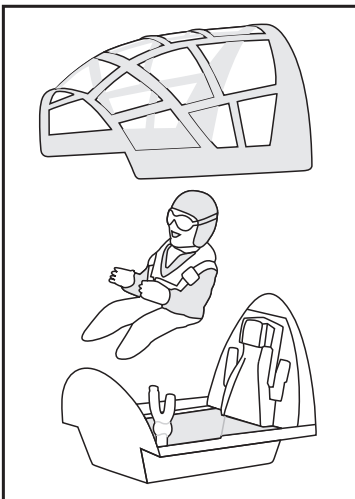

Fuselage top side

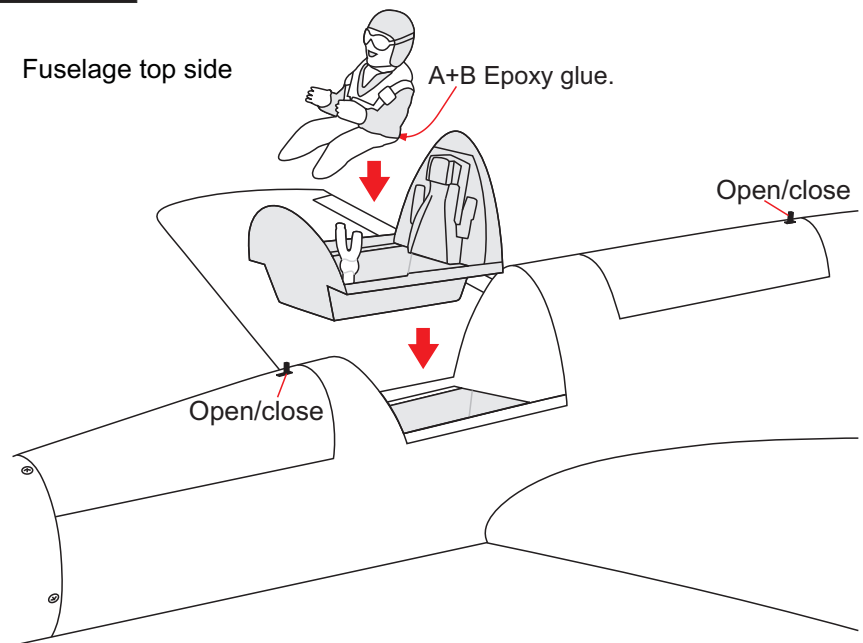

Position the canopy so the rear frame on the canopy is aligned with the rear edge of the cockpit opening. Use canopy glue to secure the canopy to the canopy hatch. Use low-tack tape to hold the canopy in position until the glue fully cures. Wrap the tape completely around the canopy hatch.

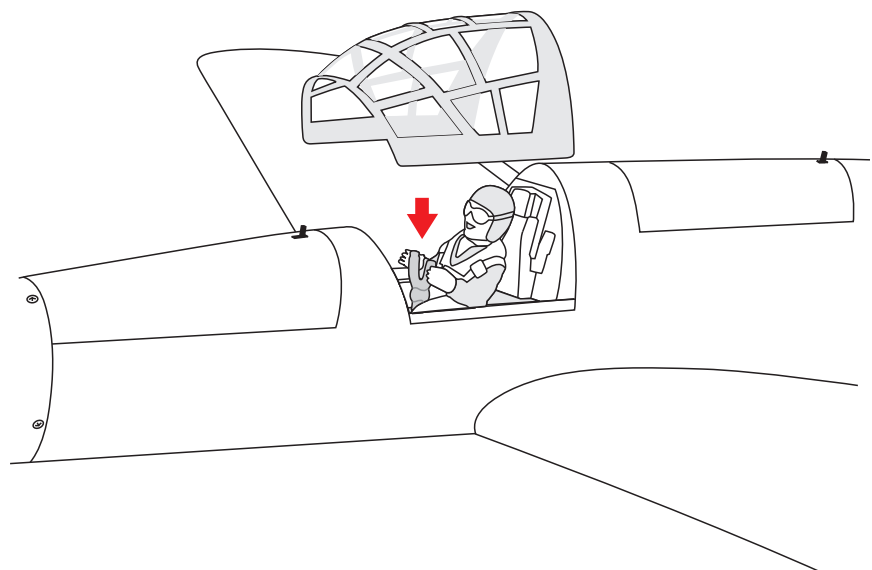

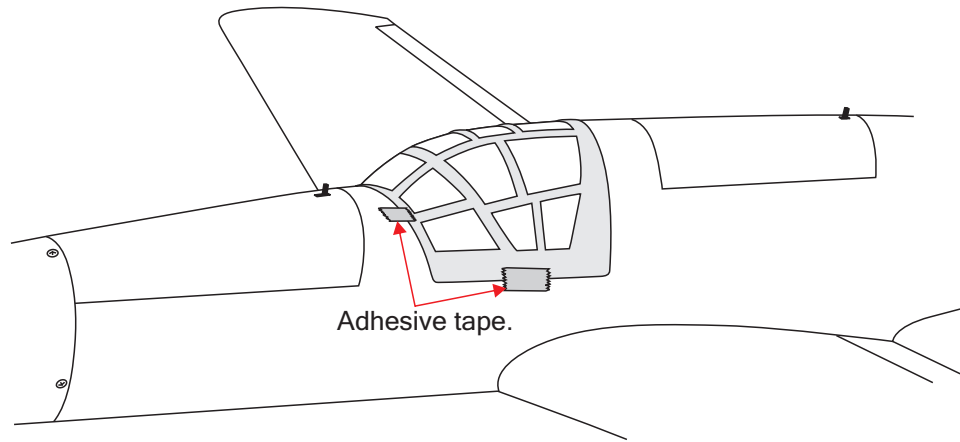

14. PLASTIC PARTS OF FUSELAGE

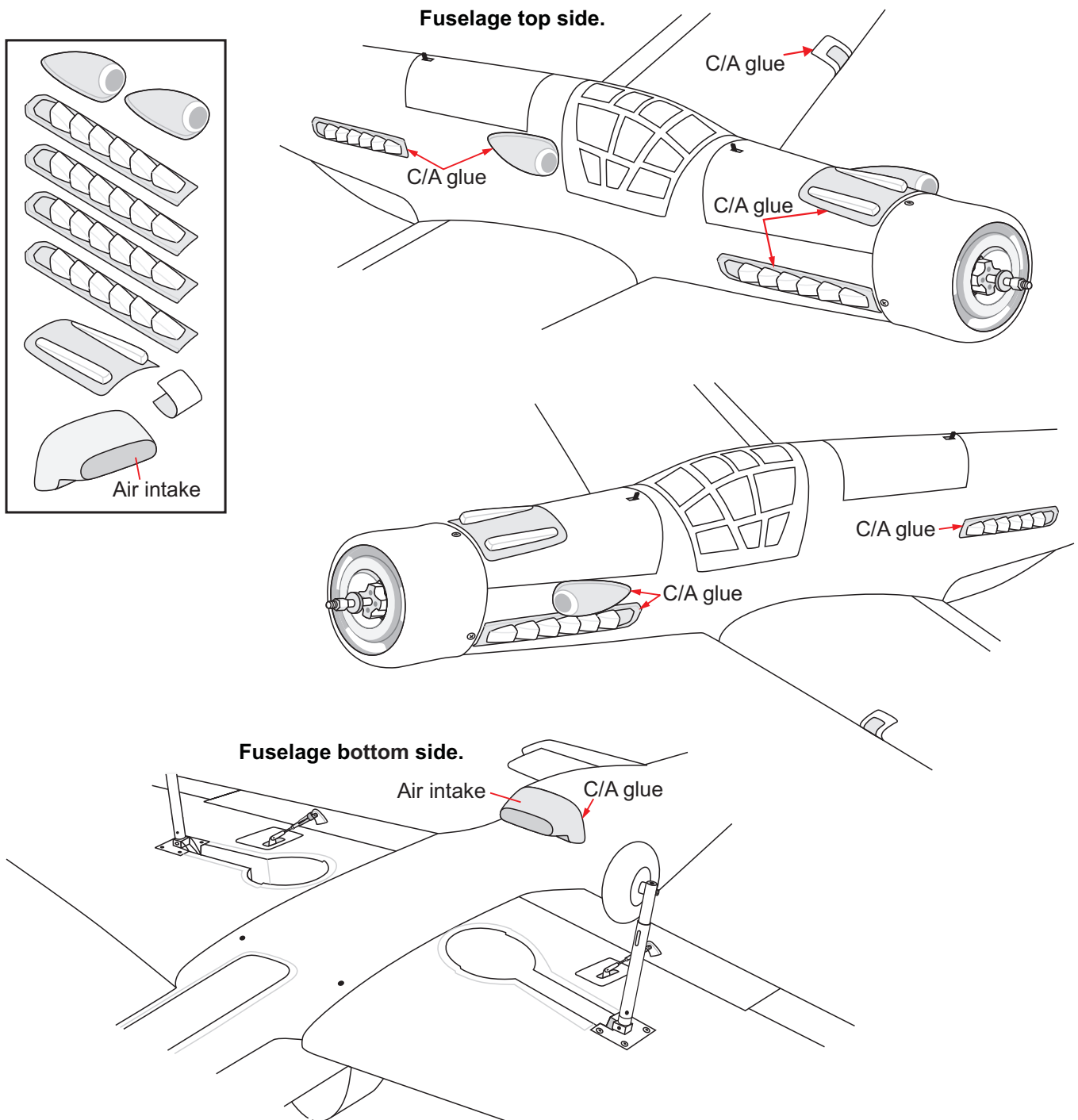

15. INSTALLING THE SPINNER, PROPELLER

Fuselage top side.

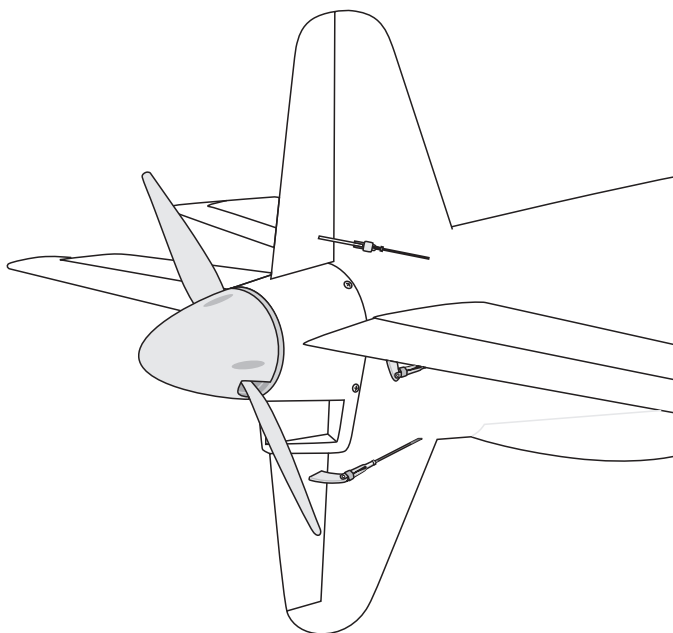
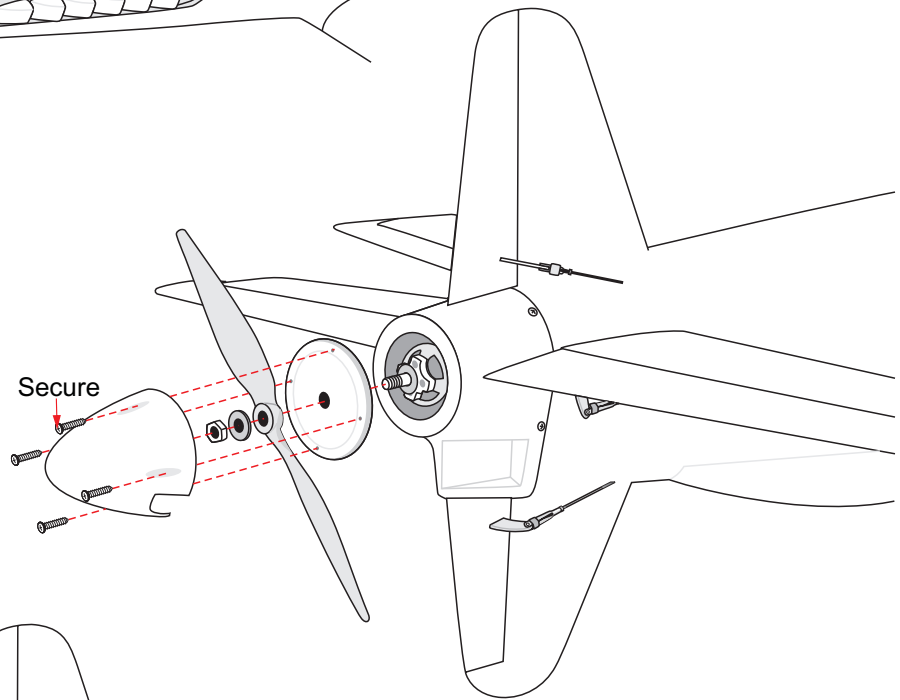
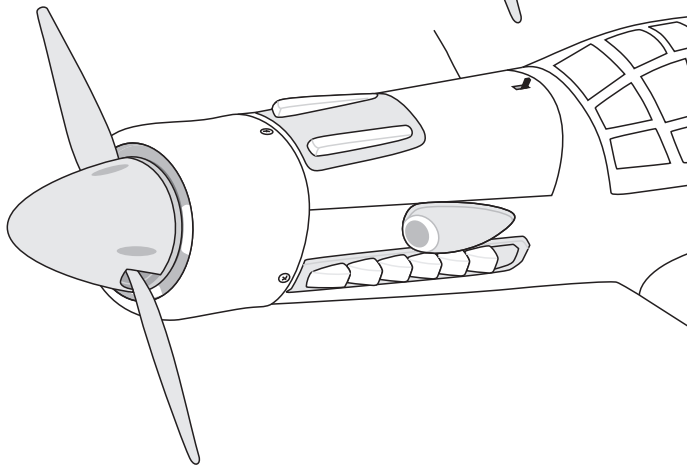
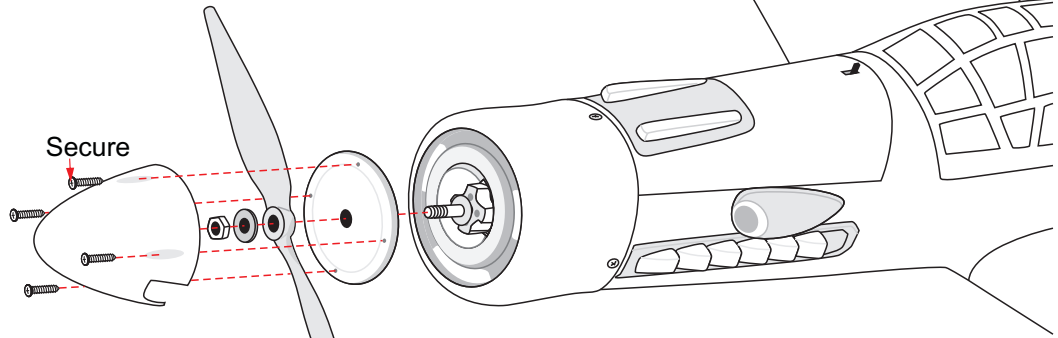
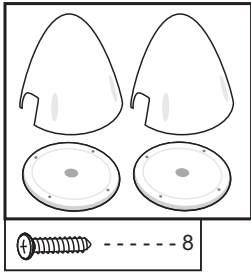

BALANCING

1) It is critical that your airplane be balanced correctly. Improper balance will cause your plane to lose control and crash.

THE CENTER OF GRAVITY IS LOCATED **175MM** BACK FROM THE LEADING EDGE OF THE WING.

2) Mount the wing to the fuselage. Using a couple of pieces of masking tape, place them on the top side of the wing **175mm** back from the leading edge, at the fuselage sides.

3) Turn the airplane upside down. Place your fingers on the masking tape and carefully lift the plane.

Accurately mark the balance point on the top of the wing on both sides of the fuselage. The balance point is located **175mm** back from the leading edge. This is the balance point at which your model should balance for your first flights. Later, you may wish to experiment by shifting the balance up to 10mm forward or back to change the flying characteristics. Moving the balance forward may improve the smoothness and arrow-like tracking, but it may then require more speed for take off and make it more difficult to slow down for landing. Moving the balance aft makes the model more agile with a lighter and snappier "feel". In any case, please start at the location we recommend.

With the wing attached to the fuselage, all parts of the model installed (ready to fly), and empty fuel tanks, hold the model at the marked balance point with the stabilizer level.

Lift the model. If the tail drops when you lift, the model is "tail heavy" and you must add weight* to the nose. If the nose drops, it is "nose heavy" and you must add weight* to the tail to balance.

*If possible, first attempt to balance the model by changing the position of the receiver battery and receiver. If you are unable to obtain good balance by

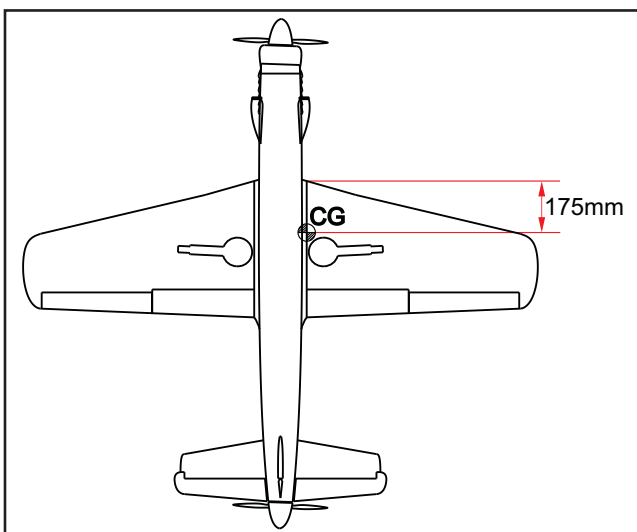

CONTROL THROWS

1) We highly recommend setting up a plane using the control throws listed.

2) The control throws should be measured at the widest point of each control surface.

3) Check to be sure the control surfaces move in the correct directions.

Control throw Ailerons:

Low: 12 mm up / down.

High: 14 mm up / down.

Control throw Flaps:

Mid: 25 mm down.

Control throw Elevators:

Low: 8 mm up / down.

High: 10 mm up / down.

Control throw Rudder:

Low: 25 mm left / right.

High: 30 mm left / right.

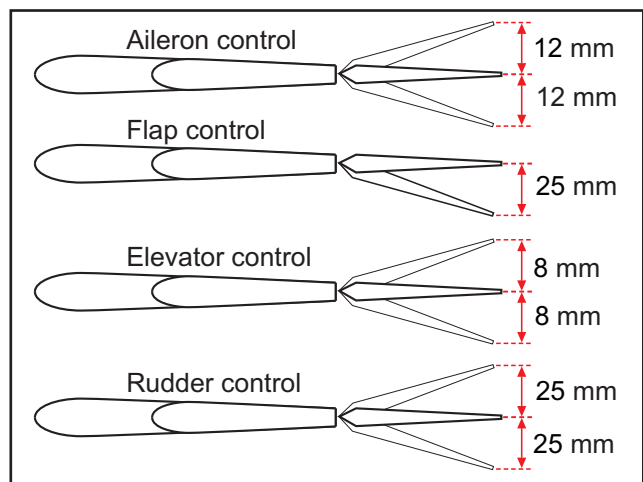

PRE-FLIGHT CHECK

1) Completely charge your transmitter and receiver batteries before your first day of flying.

2) Check every bolt and every glue joint in your plane to ensure that everything is tight and well bonded.

3) Double check the balance of the airplane.

4) Check the control surface.

5) Check the receiver antenna. It should be fully extended and not coiled up inside the fuselage. Check the receiver antenna. It should be fully extended and not coiled up inside the fuselage.

6) Properly balance the propeller.

We wish you many safe and enjoyable flights with your DORNIER DO335.

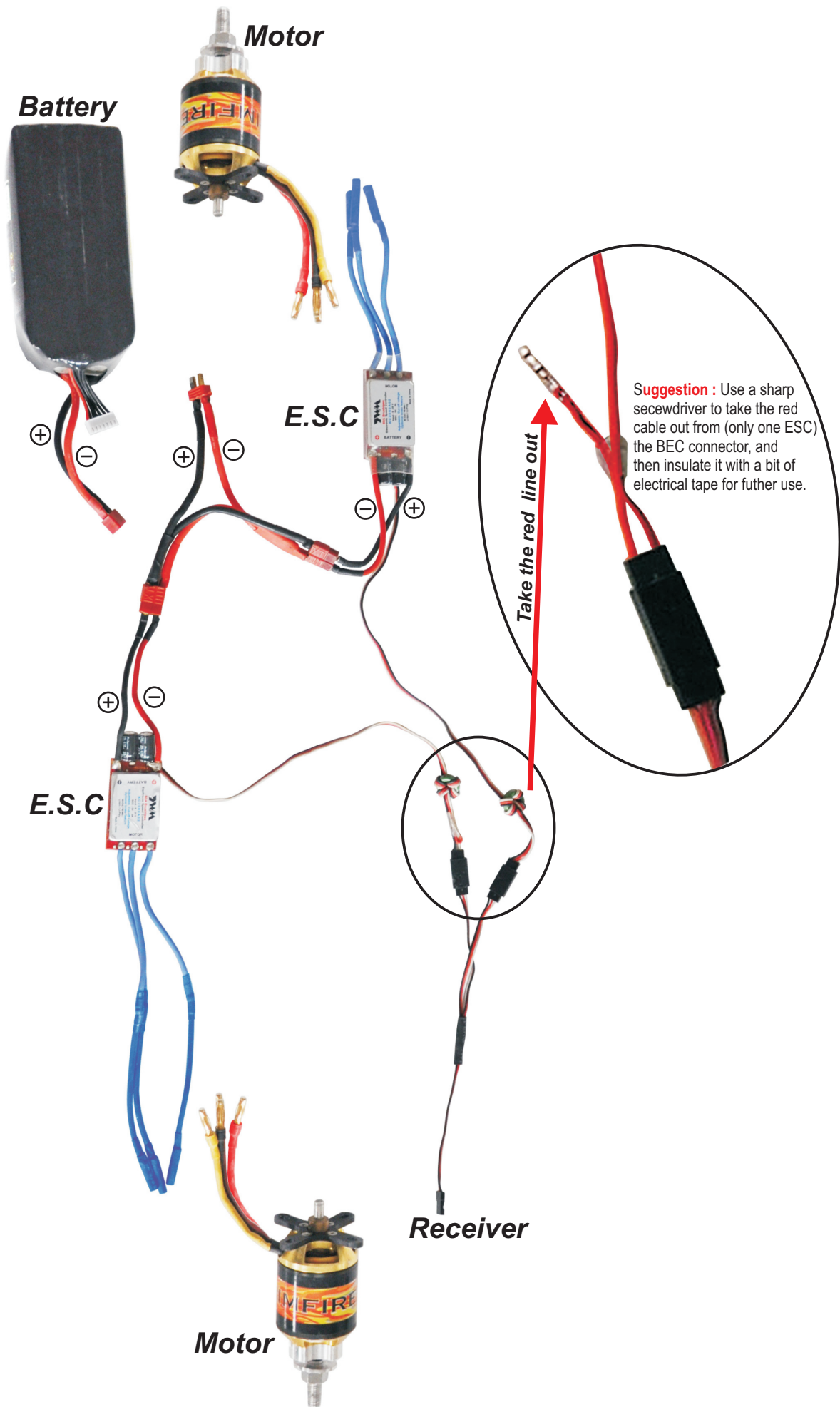

I/C FLINGT WARNINGS

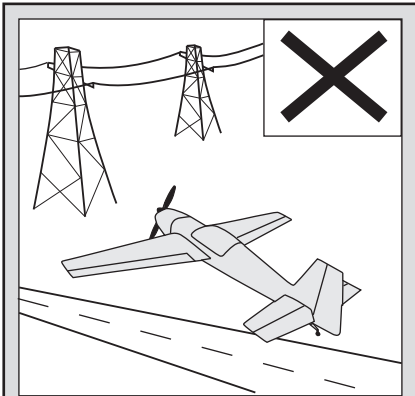

NEVER fly near power lines, aerials or other dangerous areas including airports, motorways etc.

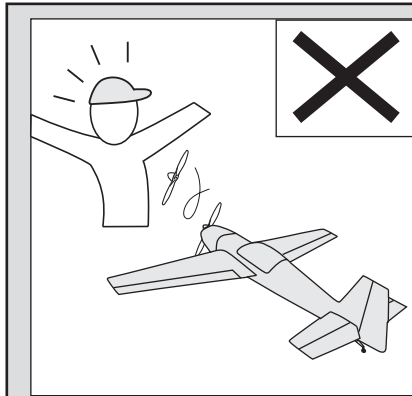

ALWAYS adjust the engine from behind the propeller, and do not allow any part of your body to be in line with the propeller.

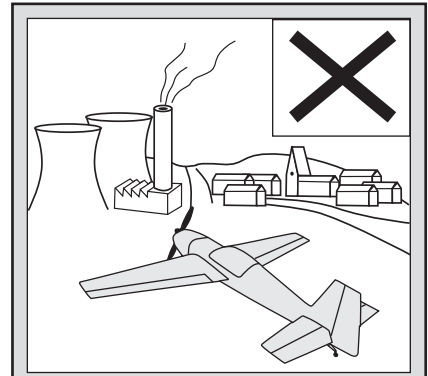

Always operate in open areas, away from factories, hospitals, schools, buildings and houses etc. **NEVER** fly your aircraft close to people or built up areas.

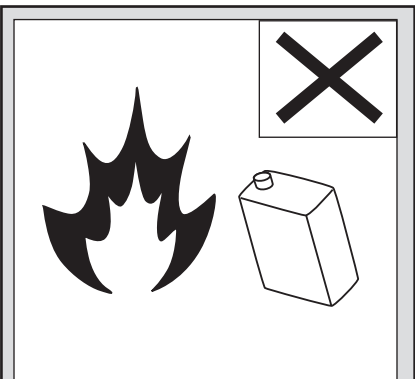

DO NOT dispose of empty fuel containers on a fire, this can lead to an explosion.

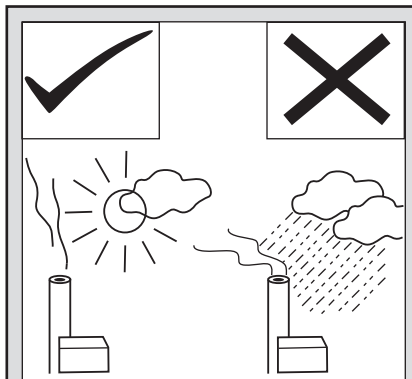

NEVER fly in wet conditions or on windy or stormy days.

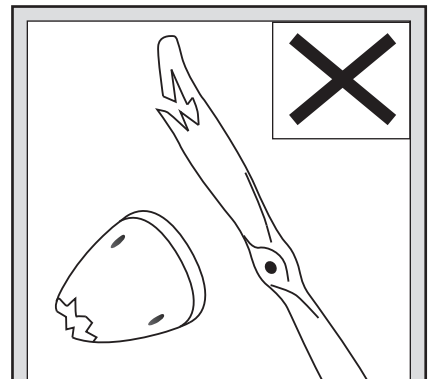

NEVER use damaged or deformed propellers or spinners.

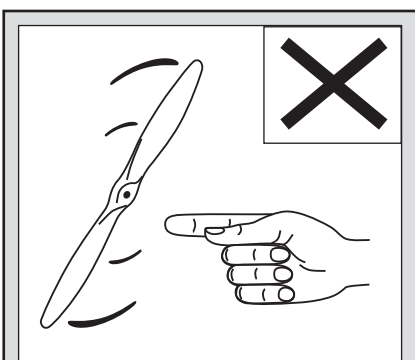

THE PROPELLER IS DANGEROUS.

Keep fingers, clothing (ties, shirt sleeves, scarves) or any other loose objects that could be caught or drawn in, away from the propeller. Take care at **ALL** times.

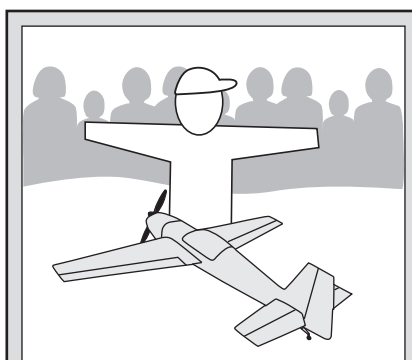

Keep all onlookers (especially small children and animals) well back from the area of operation. This is a flying aircraft, which will cause serious injury in case of impact with a person or animal.